

WT56F108
3T 8052 Micro-controller
with ADC + LCD Driver (FLASH)

Data Sheet

Rev. 1.0

June 2015

Copyright Notice

This data sheet is copyrighted by Weltrend Semiconductor, Inc. Do not reproduce, transform to any other format, or send/transmit any part of this documentation without the express written permission of Weltrend Semiconductor, Inc.

Disclaimers

Right to make change –

This document provides technical information for user. Weltrend Semiconductor, Inc. reserves the right to make change without further notice to any products herein.

Table of Contents

1. General Description	3
2. Features	3
3. Block Diagram	5
3.1 System Clock Tree	6
4. Pin Configuration	7
4.1 Pin Description	10
4.2 Pin Summary	14
4.3 Port Structure	16
5. Normal Function	20
5.1 CPU	20
5.2 RAM	20
5.3 Flash Memory	21
5.4 Memory Mapping	22
5.5 In-System Programming (ISP) (Important!!! Must Read!!!)	26
5.6 Timer/Counter	28
5.7 Reset	32
5.8 System Clock and Clock sources	33
6. Enhanced Function	34
6.1 External Special Function Register (XFR)	34
6.2 I/O Port	39
6.3 Interrupt	53
6.4 Universal Asynchronous Receiver-Transmitter (UART)	61
6.5 External Interrupt Request (IRQ)	66
6.6 Pulse Width Modulation (PWM)	68
6.7 Power Management	73
6.8 12 MHz RC Oscillator Calibration	84
6.9 Watchdog Timer and Watch Timer	87
6.10 LCD Driver	91
6.11 Enhanced Timer/Counter	99
6.12 Analog/Digital Converter (ADC)	103
6.13 Low Voltage Detection Reset (LVDR)	108
6.14 Emulated E ² PROM	110
6.15 Code Option	113
6.16 Read Out Protection & Code Encryption	121

7. Electrical Characteristics	122
7.1 Absolute Maximum Ratings	122
7.2 Recommended Operating Parameters	122
7.3 DC Electrical Characteristics ($V_{DD} = 1.8V \sim 3.6V, -40^{\circ}C \sim +85^{\circ}C$)	123
7.4 AC Electrical Characteristics ($T_A = 25^{\circ}C$)	124
7.5 Internal 12 MHz RC Oscillator Temperature Tolerance table.....	125
7.6 A/D Converting Characteristics ($T_A = 25^{\circ}C$).....	126
7.7 Low Voltage Reset (LVR) & Low Voltage Detection Reset (LVDR) Electrical Characteristics	126
7.8 Thermal Resistance Notice	127
8. Application Circuits	128
8.1 Power Supply	128
8.2 Oscillator Circuits	128
8.3 RESET Circuit.....	129
8.4 Standard Circuit	130
8.5 Development board circuits (4COM LCD)	131
9. Product Naming Rule.....	132
10. Ordering Information	132
11. Pad Diagram & Location Table.....	133
12. Package Dimension	135
12.1 64-Pin LQFP	135
12.2 44-Pin LQFP	136
12.3 SOP-28	137
13. Development Tools	138
14. Revision History.....	142

1. General Description

The WT56F108 is a general-purpose single chip Microcontroller with LCD function provided by Weltrend, a well-known IC Design House in Taiwan. In addition to using the advanced 3T 8052 single-chip core, wide and low operating voltage range (1.8V ~ 3.6V), and high noise immunity, the product consists of 8Kx8 Flash Program Memory, 384x8 RAM, abundant peripheral resources and versatile power management (refer to the content for more details).

The above features make the WT56F108 suitable for a wide range of applications, especially in areas such as home appliances with LCD (rice cooker, microwave oven, and toaster), Thermo-Hygrometer, bidirectional car alarm, remote controller of air conditioner, and so on.

The WT56F108 is a low cost high performance product with kinds of package to replace the mainstream products on the market (refer to "Pin Configuration" section for more details). In order to contribute more competitive ability, Weltrend also provides dice and wafer sale for the customer.

2. Features

WT56F108 is an advanced 8052 Micro-controller with LCD Driver, and it also provides the following features.

- 3T 8052 core, MCS-51 instruction set compatible
- Instruction execution time: Min. = 249.99ns @12 MHz
- 384 Bytes of RAM (256 Bytes of standard 8052 internal Data RAM and 128 Bytes of external RAM)
- 8K Bytes of flash memory for program storage
- Supporting Internal & External Clock Oscillators:
 - ◆ Internal clock: 12 MHz RC oscillator (frequency tolerance $\pm 10\%$) & 32 kHz RC oscillator (frequency tolerance $\pm 30\%$)
 - ◆ External clock: External DC ~ 16 MHz Crystal Oscillator
- Two 16-bit Timer/Counters (Timer0 & Timer1)
- One Watchdog Timer (WDT)
- One Watch Timer
- One 16-bit Enhanced Timer with Capture function
- One UART (UART0), support baud rate 1200 bps ~ 230400 bps (at 12 MHz)
- Emulated E²PROM @ 2.4V ~ 3.6V
- Two 16-bit PWMs (PWM0 & PWM1)
- LCD Control Driver
 - ◆ 4 COM x 40 SEG or 4 COM x 32 SEG
- 12-channel 10-bit Analog/Digital Converter (ADC0 ~ ADC11)
- Three power-saving modes: Sleep mode, Green mode and Idle mode
- 8 external Interrupt IRQ pins (IRQ0 ~ IRQ7)
- 56 programmable bi-directional I/O pins, 12 of them with both high current sink/source ability (10 mA)
- Programmable Low Voltage Detection Reset (LVDR)
- On-chip Power On Reset (POR) and Low Voltage Reset (LVR)
- Built-in single-wire In-Circuit Emulator (ICE) and In-System Programming (ISP)
- Read Out Protection and Code Encryption
- Operating voltage range: 2.4V ~ 3.6V@12 MHz
1.8V ~ 3.6V@6 MHz
- Operating temperature: -40°C ~ +85°C
- Package (**Green Package**): LQFP64, LQFP44 & SOP28

For more details about WT56F108 power consumption (@3V) in different operation modes, please refer to Section 6.7 Power Management.

- ✓ If you want to use the UART must consider if IRC 12 MHz frequency offset is greater than $\pm 3\%$, must use the external LDO regulator if necessary
- ✓ This product provides external 32768 Hz crystal oscillator to calibrate IRC 12 MHz automatically and keeps the frequency tolerance $< \pm 1\%$

3. Block Diagram

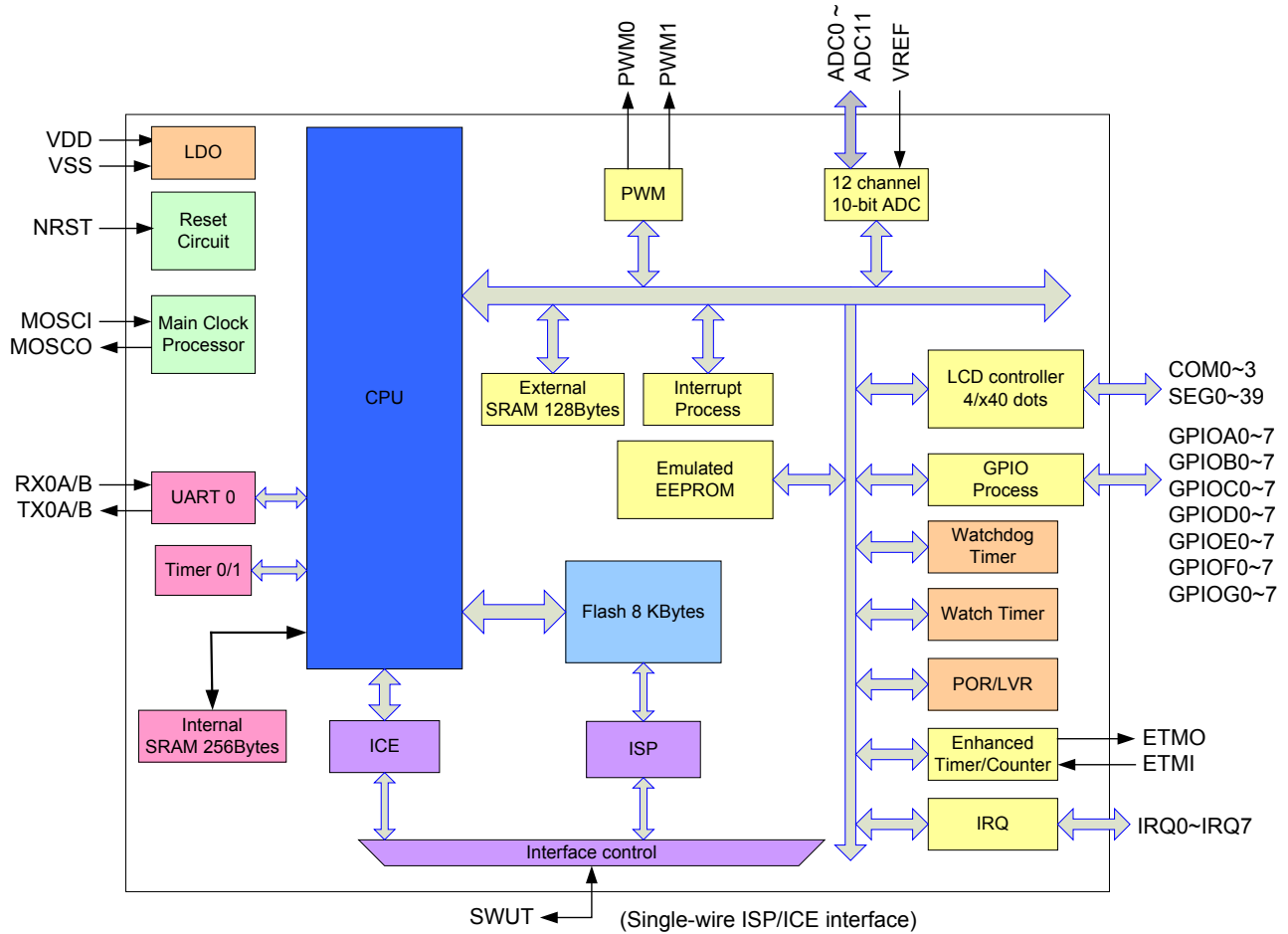

3.1 System Clock Tree

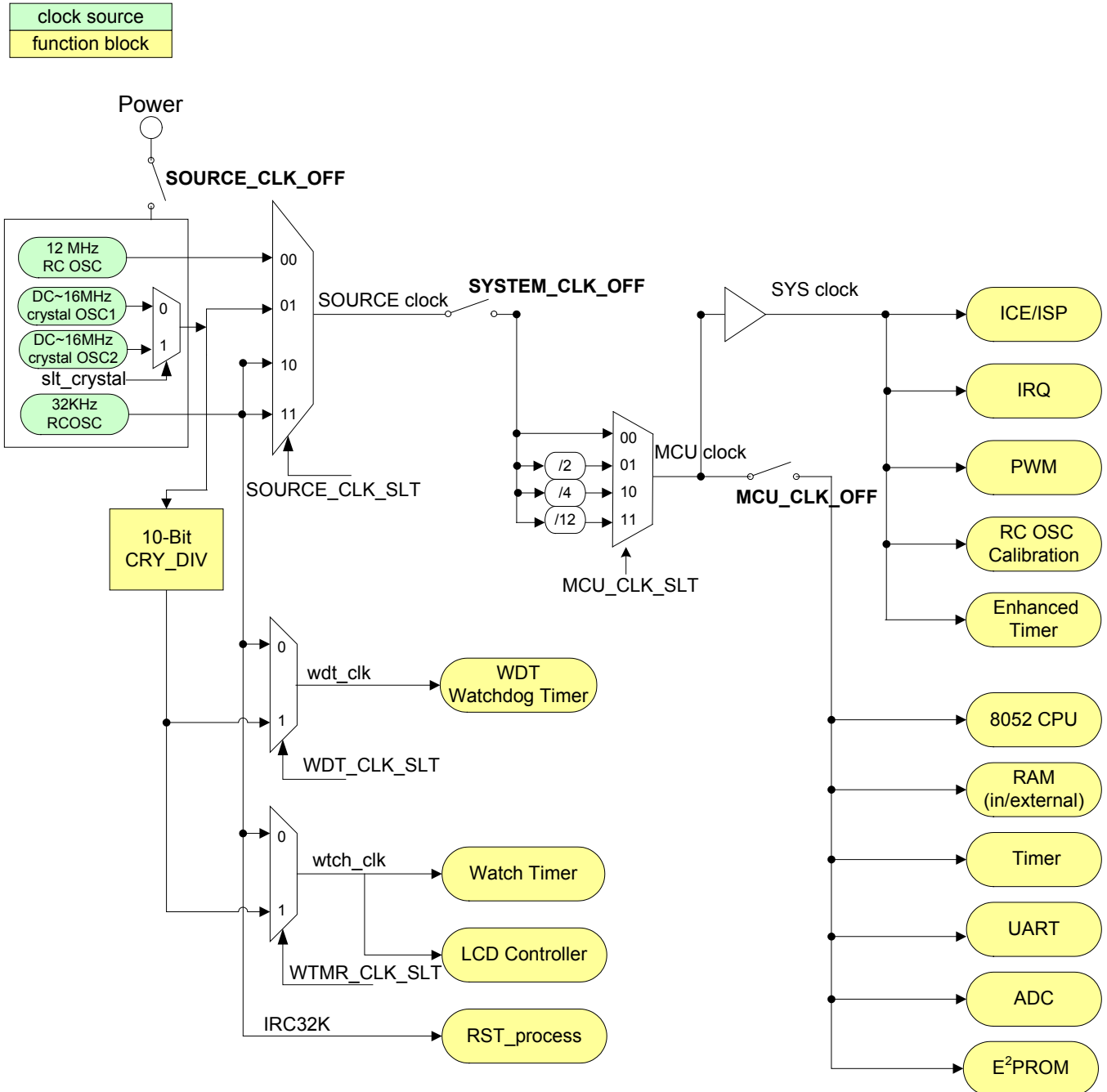

* When using the external Crystal Oscillator, please select the corresponding driving ability according to its frequency. Refer to Oscillator Driver Control Register (XFR: 0x08) CRY_12M_DR[2:0] bit for more details.

4. Pin Configuration

WT56F108-RG64AWT 64-Pin LQFP (pins can replace EM78P469)

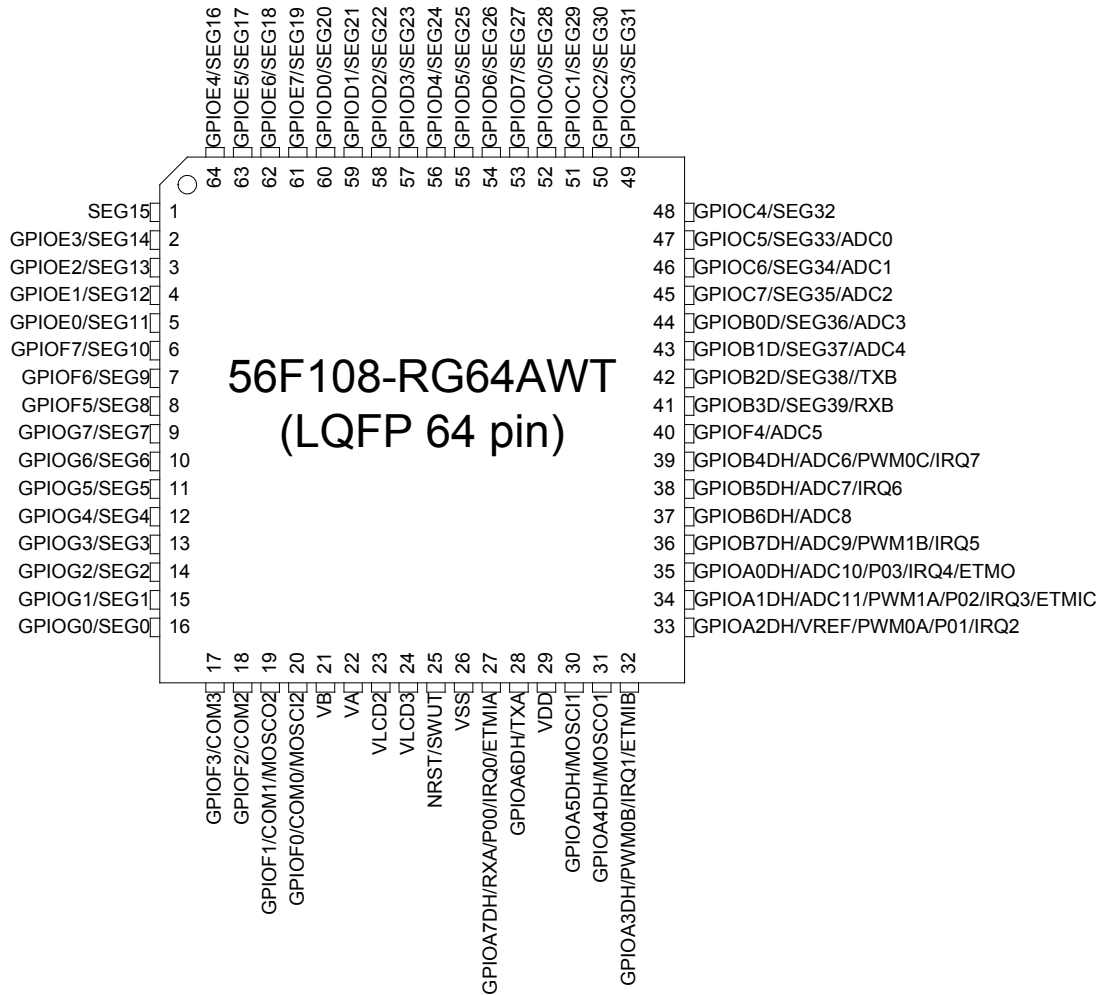

WT56F108-RG44AWT 44-Pin LQFP (pins can replace EM78P468N / EM78P468NB / EM78P469)

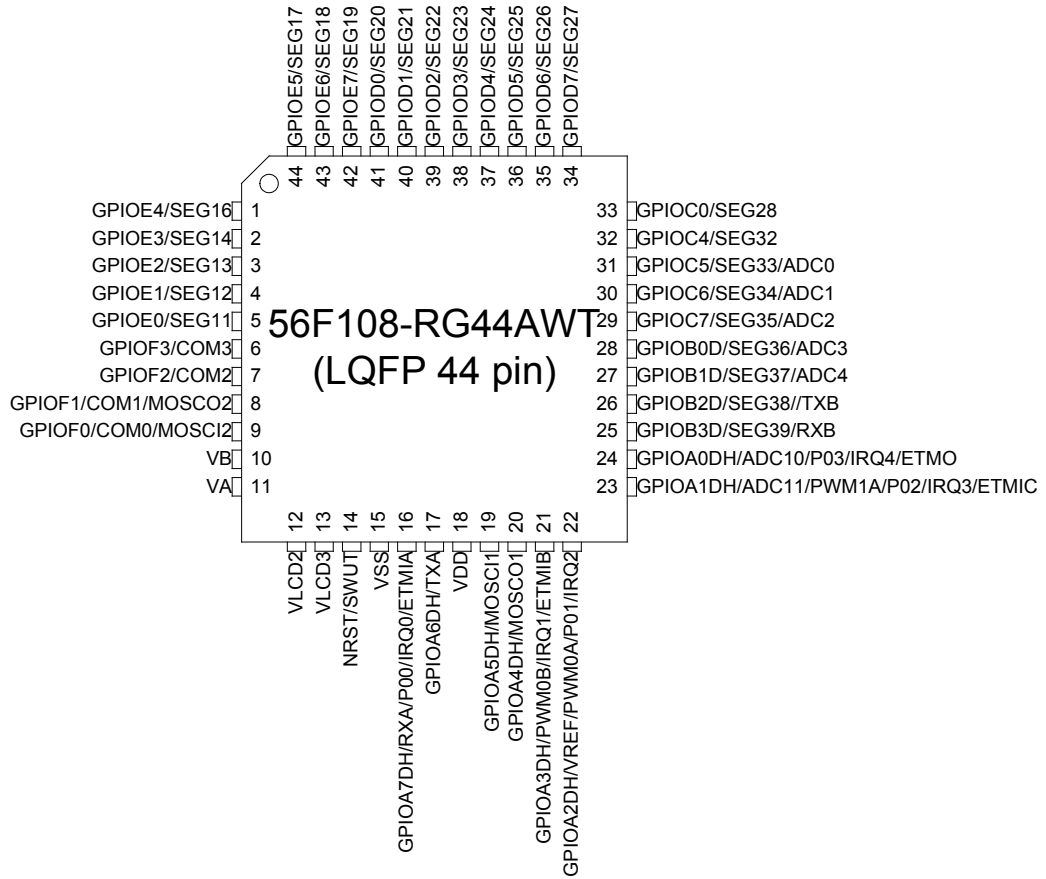

WT56F108-SG28AWT 28-Pin SOP (pins can replace SN8P2604A (SONIX))

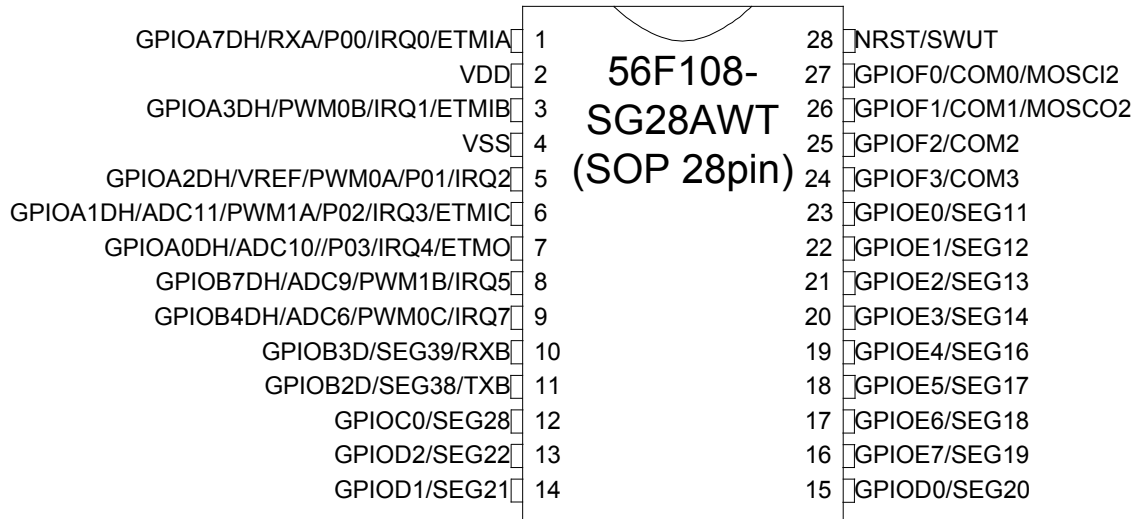

4.1 Pin Description

Pin Number			Pin Name		Primary Functions	
RG64A WT	RG44A WT	SG28A WT		I/O	Descriptions	Circuit Type
1			SEG15	O	SEG15: LCD segment 15	E4
2	2	20	GPIOE3/ SEG14	I/O	GPIOE3: General-purpose I/O with push-pull SEG14: LCD segment 14	E4
3	3	21	GPIOE2/ SEG13	I/O	GPIOE2: General-purpose I/O with push-pull SEG13: LCD segment 13	E4
4	4	22	GPIOE1/ SEG12	I/O	GPIOE1: General-purpose I/O with push-pull SEG12: LCD segment 12	E4
5	5	23	GPIOE0/ SEG11	I/O	GPIOE0: General-purpose I/O with push-pull SEG11: LCD segment 11	E4
6			GPIOF7/ SEG10	I/O	GPIOF7: General-purpose I/O with push-pull SEG10: LCD segment 10	E4
7			GPIOF6/ SEG9	I/O	GPIOF6: General-purpose I/O with push-pull SEG9: LCD segment 9	E4
8			GPIOF5/ SEG8	I/O	GPIOF5: General-purpose I/O with push-pull SEG8: LCD segment 8	E4
9			GPIOG7/ SEG7	I/O	GPIOG7: General-purpose I/O with push-pull SEG7: LCD segment 7	E4
10			GPIOG6/ SEG6	I/O	GPIOG6: General-purpose I/O with push-pull SEG6: LCD segment 6	E4
11			GPIOG5/ SEG5	I/O	GPIOG5: General-purpose I/O with push-pull SEG5: LCD segment 5	E4
12			GPIOG4/ SEG4	I/O	GPIOG4: General-purpose I/O with push-pull SEG4: LCD segment 4	E4
13			GPIOG3/ SEG3	I/O	GPIOG3: General-purpose I/O with push-pull SEG3: LCD segment 3	E4
14			GPIOG2 SEG2	I/O	GPIOG2: General-purpose I/O with push-pull SEG2: LCD segment 2	E4
15			GPIOG1 SEG1	I/O	GPIOG1: General-purpose I/O with push-pull SEG1: LCD segment 1	E4
16			GPIOG0/ SEG0	I/O	GPIOG0: General-purpose I/O with push-pull SEG0: LCD segment 0	E4
17	6	24	GPIOF3/ COM3	I/O	GPIOF3: General-purpose I/O with push-pull COM3: LCD common 3	E4
18	7	25	GPIOF2/ COM2	I/O	GPIOF2: General-purpose I/O with push-pull COM2: LCD common 2	E4
19	8	26	GPIOF1/ COM1/ MOSCO2	I/O	GPIOF1: General-purpose I/O with push-pull COM1: LCD common 1 MOSCO2: the crystal output pin of path 2	B3
20	9	27	GPIOF0/ COM0/ MOSCI2	I/O	GPIOF0: General-purpose I/O with push-pull COM0: LCD common 0 MOSCI2: the crystal oscillator input pin of path 2	B3
21	10		VB	O	Connect the LCD capacitors B	
22	11		VA	O	Connect the LCD capacitors A	

Pin Number			Pin Name		Primary Functions	
RG64A WT	RG44A WT	SG28A WT		I/O	Descriptions	Circuit Type
23	12		VLCD2	O	2/3 bias voltage	
24	13		VLCD3	O	1/3(1/2) bias voltage	
25	14	28	NRST/ SWUT	I	NRST: reset pin SWUT: single-wire ISP/ICE interface	D
26	15		VSS	GND	Core ground	
27	16	1	GPIOA7DH/ RXA/ P00/ IRQ0/ ETMIA	I/O	GPIOA7DH: General-purpose I/O with programmable high current sink/source push-pull or open drain RXA: Receive data input of path A of UART P00: Mapping to 8052 P0.0 IRQ0: External Interrupt Request 0 ETMIA: Enhanced Timer/Counter clock source capture input of path A	A
28	17		GPIOA6DH/ TXA	I/O	GPIOA6DH: General-purpose I/O with programmable high current sink/source push-pull or open drain TXA: Transmit data output of path A of UART	A
29	18	2	VDD	PWR	VDD power +3.3V	
30	19		GPIOA5DH/ MOSCI1	I/O	GPIOA5DH: General-purpose I/O with programmable high current sink/source push-pull or open drain MOSCI1: the crystal oscillator input pin of path 1	B1
31	20		GPIOA4DH/ MOSCO1	I/O	GPIOA4DH: General-purpose I/O with programmable high current sink/source push-pull or open drain MOSCO1: the crystal oscillator output pin of path 1	B1
32	21	3	GPIOA3DH/ PWM0B/ IRQ1/ ETMIB	I/O	GPIOA3DH: General-purpose I/O with programmable high current sink/source push-pull or open drain PWM0B: PWM0 output pin of path B IRQ1: External Interrupt Request 1 ETMIB: Enhanced Timer/Counter clock source capture input of path B	A
		4	VSS	GND	Core ground	
33	22	5	GPIOA2DH/ VREF/ PWM0A/ P01/ IRQ2	I/O	GPIOA2DH: General-purpose I/O with programmable high current sink/source push-pull or open drain VREF: Analog/Digital Converter Voltage Reference Input pin PWM0A: PWM0 output pin of path A P01: Mapping to 8052 P0.1 IRQ2: External Interrupt Request 2	E2
34	23	6	GPIOA1DH/ ADC11/ PWM1A/ P02/ IRQ3/ ETMIC	I/O	GPIOA1DH: General-purpose I/O with programmable high current sink/source push-pull or open drain ADC11: Analog/Digital Converter Input 11 PWM1A: PWM1 output pin of Path A P02: Mapping to 8052 P0.2 IRQ3: External Interrupt Request 3 ETMIC: Enhanced Timer/Counter clock source capture input of path C	C1

Pin Number			Pin Name		Primary Functions	
RG64A WT	RG44A WT	SG28A WT		I/O	Descriptions	Circuit Type
35	24	7	GPIOA0DH/ ADC10/ P03/ IRQ4/ ETMO	I/O	GPIOA0DH: General-purpose I/O with programmable high current sink/source push-pull or open drain ADC10: Analog/Digital Converter Input 10 P03: Mapping to 8052 P0.3 IRQ4: External Interrupt Request 4 ETMO: Compare Result Output of Enhanced Timer/Counter	C1
36		8	GPIOB7DH/ ADC9/ PWM1B/ IRQ5	I/O	GPIOB7DH: General-purpose I/O with programmable high current sink/source push-pull or open drain ADC9: Analog/Digital Converter Input 9 PWM1B: PWM1 output pin of path B IRQ5: External Interrupt Request 5	C1
37			GPIOB6DH/ ADC8	I/O	GPIOB6DH: General-purpose I/O with programmable high current sink/source push-pull or open drain ADC8 Analog/Digital Converter Input 8	C1
38			GPIOB5DH/ ADC7/ IRQ6	I/O	GPIOB5DH: General-purpose I/O with programmable high current sink/source push-pull or open drain ADC7 Analog/Digital Converter Input 7 IRQ6 External Interrupt Request 6	C1
39		9	GPIOB4DH/ ADC6/ PWM0C/ IRQ7	I/O	GPIOB4DH: General-purpose I/O with programmable high current sink/source push-pull or open drain ADC6: Analog/Digital Converter Input 6 PWM0C: PWM0 output pin of path C IRQ7: External Interrupt Request 7	C1
40			GPIOF4/ ADC5	I/O	GPIOF4: General-purpose I/O with push-pull ADC5: Analog/Digital Converter Input 5	E5
41	25	10	GPIOB3D/ SEG39/ RXB	I/O	GPIOB3: General-purpose I/O with programmable open drain SEG39: LCD segment 39 RXB: Receive data input of path B of UART	E6
42	26	11	GPIOB2D/ SEG38/ TXB	I/O	GPIOB2: General-purpose I/O with programmable open drain SEG38: LCD segment 38 TXB: Transmit data output of path B of UART	E6
43	27		GPIOB1D/ SEG37/ ADC4	I/O	GPIOB1: General-purpose I/O with programmable open drain SEG37: LCD segment 37 ADC4: Analog/Digital Converter Input 4	E6
44	28		GPIOB0D/ SEG36/ ADC3	I/O	GPIOB0: General-purpose I/O with programmable open drain SEG36: LCD segment 36 ADC3: Analog/Digital Converter Input 3	E6
45	29		GPIOC7/ SEG35/ ADC2	I/O	GPIOC7: General-purpose I/O with push-pull SEG35: LCD segment 35 ADC2: Analog/Digital Converter Input 2	E5
46	30		GPIOC6/ SEG34/ ADC1	I/O	GPIOC6: General-purpose I/O with push-pull SEG34: LCD segment 34 ADC1: Analog/Digital Converter Input 1	E5

Pin Number			Pin Name		Primary Functions	
RG64A WT	RG44A WT	SG28A WT		I/O	Descriptions	Circuit Type
47	31		GPIOC5/ SEG33/ ADC0	I/O	GPIOC5: General-purpose I/O with push-pull SEG33: LCD segment 33 ADC0: Analog/Digital Converter Input 0	E5
48	32		GPIOC4/ SEG32	I/O	GPIOC4: General-purpose I/O with push-pull SEG32: LCD segment 32	E4
49			GPIOC3/ SEG31	I/O	GPIOC3: General-purpose I/O with push-pull SEG31: LCD segment 31	E4
50			GPIOC2/ SEG30	I/O	GPIOC2: General-purpose I/O with push-pull SEG30: LCD segment 30	E4
51			GPIOC1/ SEG29	I/O	GPIOC1: General-purpose I/O with push-pull SEG29: LCD segment 29	E4
52	33	12	GPIOC0/ SEG28	I/O	GPIOC0: General-purpose I/O with push-pull SEG28: LCD segment 28	E4
53	34		GPIOD7/ SEG27	I/O	GPIOD7: General-purpose I/O with push-pull SEG27: LCD segment 27	E4
54	35		GPIOD6/ SEG26	I/O	GPIOD6: General-purpose I/O with push-pull SEG26: LCD segment 26	E4
55	36		GPIOD5/ SEG25	I/O	GPIOD5: General-purpose I/O with push-pull SEG25: LCD segment 25	E4
56	37		GPIOD4/ SEG24	I/O	GPIOD4: General-purpose I/O with push-pull SEG24: LCD segment 24	E4
57	38		GPIOD3/ SEG23	I/O	GPIOD3: General-purpose I/O with push-pull SEG23: LCD segment 23	E4
58	39	13	GPIOD2 SEG22	I/O	GPIOD2: General-purpose I/O with push-pull SEG22: LCD segment 22	E4
59	40	14	GPIOD1/ SEG21	I/O	GPIOD1: General-purpose I/O with push-pull SEG21: LCD segment 21	E4
60	41	15	GPIOD0/ SEG20	I/O	GPIOD0: General-purpose I/O with push-pull SEG20: LCD segment 20	E4
61	42	16	GPIOE7/ SEG19	I/O	GPIOE7: General-purpose I/O with push-pull SEG19: LCD segment 19	E4
62	43	17	GPIOE6/ SEG18	I/O	GPIOE6: General-purpose I/O with push-pull SEG18: LCD segment 18	E4
63	44	18	GPIOE5/ SEG17	I/O	GPIOE5: General-purpose I/O with push-pull SEG17: LCD segment 17	E4
64	1	19	GPIOE4/ SEG16	I/O	GPIOE4: General-purpose I/O with push-pull SEG16: LCD segment 16	E4

Note: All I/O pins are floating on Reset status.

4.2 Pin Summary

Explain each pin function in details.

Pin Name	Type	Description
PORT		
GPIOA0 ~ GPIOA7	I/O	8-bit bidirectional general-purpose I/O port
GPIOB0 ~ GPIOB7	I/O	8-bit bidirectional general-purpose I/O port
GPIOC0 ~ GPIOC7	I/O	8-bit bidirectional general-purpose I/O port
GPIOD0 ~ GPIOD7	I/O	8-bit bidirectional general-purpose I/O port
GPIOE0 ~ GPIOE7	I/O	8-bit bidirectional general-purpose I/O port
GPIOF0 ~ GPIOF7	I/O	8-bit bidirectional general-purpose I/O port
GPIOG0 ~ GPIOG7	I/O	8-bit bidirectional general-purpose I/O port
8052 Port		
P00~P03	I/O	Mapping to 8052 P0.0~P0.3
Enhanced Timer/Counter		
ETMO	O	Enhanced Timer/Counter Compare Result Output
ETMI A/B/C	I	Enhanced Timer/Counter Clock Source or Capture Input of path A, path B or path C
IRQ		
IRQ0 ~ IRQ7	I	8 External Interrupt Request Input pins
PWM		
PWM0 A/B/C	O	PWM 0 Output path A, path B or path C
PWM1 A/B	O	PWM 1 Output path A or path B
UART		
RX A/B	I	UART Receive path A or path B
TX A/B	O	UART Transmit path A or path B
ADC		
ADC0 ~ ADC11	I	12 Analog/Digital Input pins
VREF	I	Analog/Digital converter reference voltage input pins
LCD		
SEG0 ~ SEG39	O	SEGMENT of LCD driver
COM0 ~ COM3	O	COM of LCD driver
VA, VB	O	Connect the LCD capacitors A, B
VLCD2, VLCD3	O	Bias voltage
VCC & VSS		
VDD	PWR	Power
VSS	GND	Ground

Pin Name	Type	Description
OSC		
MOSCO 1/2	O	Main crystal oscillator output of path 1 or path 2
MOSCI 1/2	I	Main crystal oscillator input of path 1 or path 2
RESET		
NRST	I	CPU reset
ISP & ICE		
SWUT	I/O	Single-wire ISP & ICE interface

4.3 Port Structure

I/O Structure (Type A)

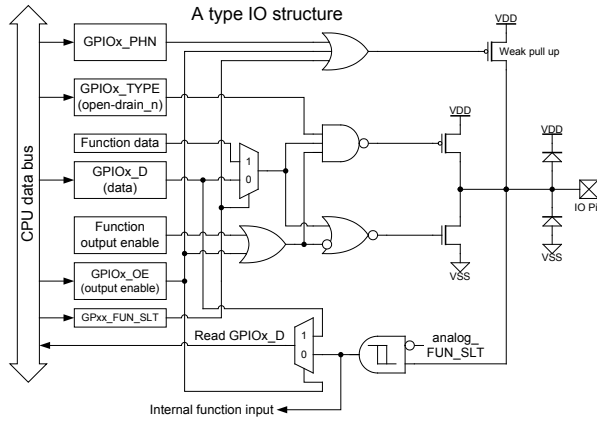

I/O Structure (Type B1)

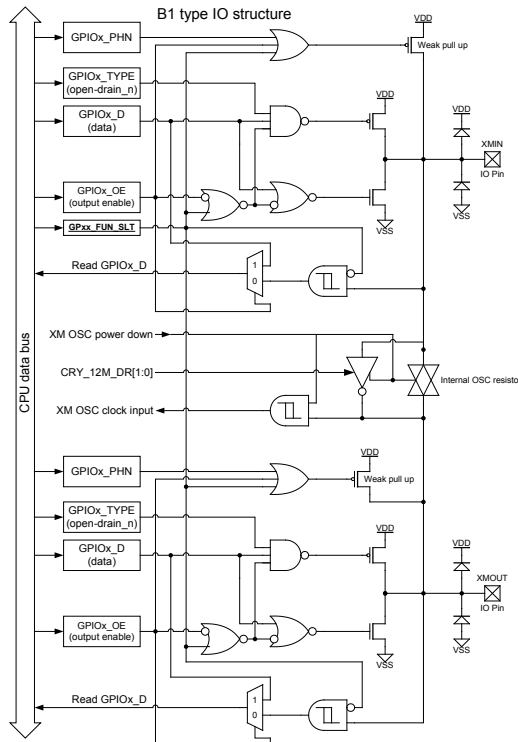

I/O Structure (Type B3)

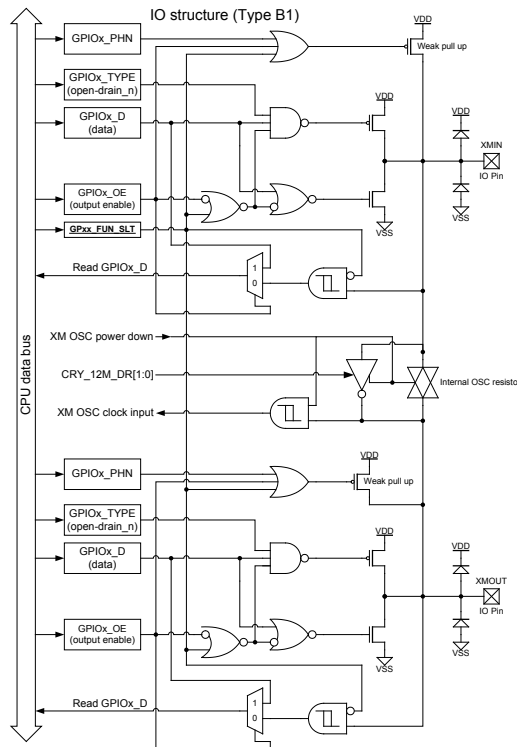

I/O Structure (Type C1)

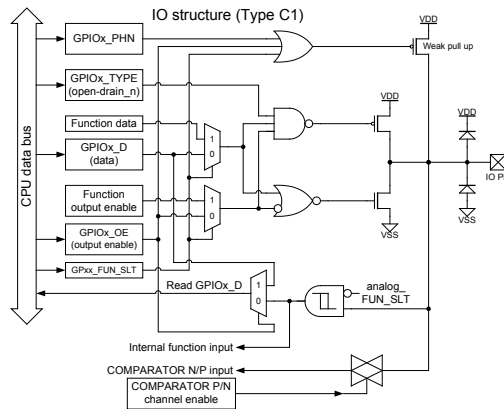

I/O Structure (Type D)

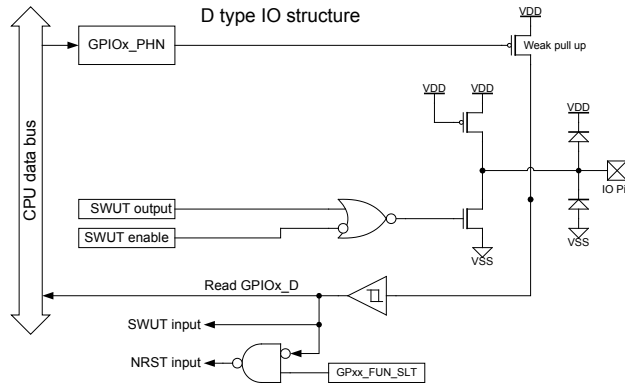

I/O Structure (Type E2)

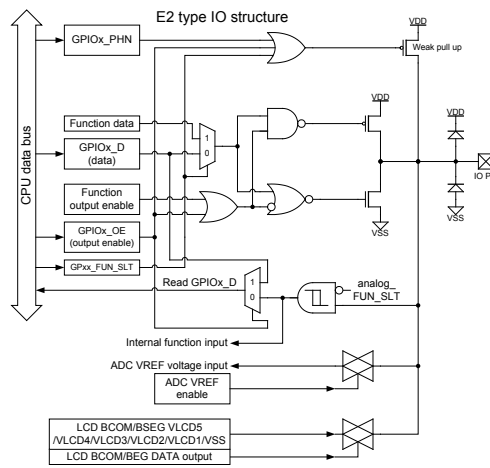

I/O Structure (Type E4)

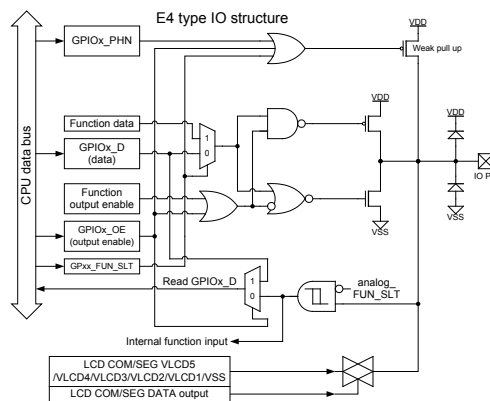

I/O Structure (Type E5)

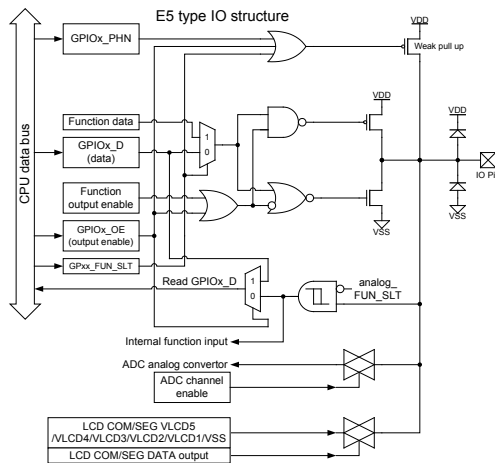

I/O Structure (Type E6)

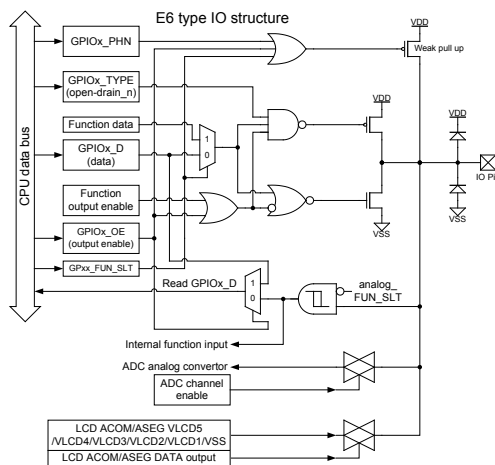

5. Normal Function

5.1 CPU

The WT56F108 has an embedded 8-bit 3T 8052 compatible CPU with 16-bit space addressable and 8-bit data access functions. The instruction execution time of 3T 8052 is four times faster than that of the conventional 12T 8052. All of the functions and Special Function Register (SFR) definitions will be described in below sections.

5.2 RAM

The WT56F108 consists of 128+256 Bytes of SRAM. The 256 Bytes of RAM is the internal RAM of the general 8052. External 128 Bytes of SRAM can be accessed by the execution of MOVX instruction.

Below figure shows a map of the RAM. For Peripheral Control Registers, see section 6.1.

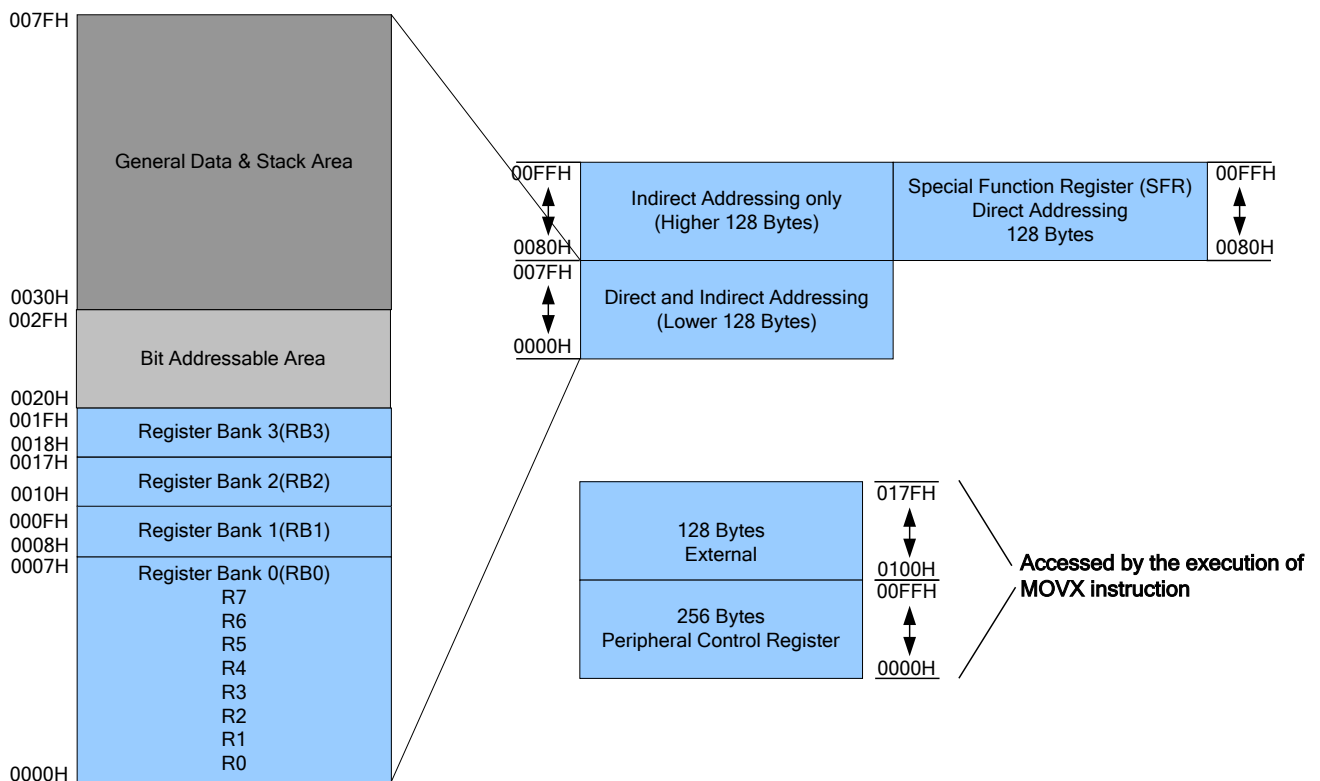

The internal SRAM contains:

128 Bytes of internal SRAM, locates from 0x0000H to 0x007FH (direct and indirect addressing is allowed)

128 Bytes of internal SRAM, locates from 0x0080H to 0x00FFH (indirect addressing)

128 Bytes of external SRAM, locates from 0x0100H to 0x017FH (accessed by MOVX instruction)

Its main purpose is for storing data in the program, and therefore it is also called Data Memory. The Data memory of WT56F108 includes the following sections:

- (1) The lower 128 bytes of internal SRAM (0000H ~ 007FH) which can be accessed by direct or indirect addressing are divided into three segments:

- ◆ **General Purpose Register:** Locates from 0000H to 001FH, 32 Bytes in total, can be divided into four register banks. Each register bank contains eight general-purpose registers (R0~R7). Four

register banks can be selected by the select bit RS1 and RS0 in the Program Status Word Register.

- ◆ **Bit Addressable Area:** Locates from 20H to 2FH, 16 Bytes in total. Each one of the 128 bits of this segment can be directly addressed by Bit Addressing.
- ◆ **General Data Area:** Locates from 0030H to 007FH, 80 Bytes are available to the user as data RAM (including the Stack area).

(2) The higher 128 bytes of internal SRAM (0080H ~ 00FFH) can be accessed by indirect addressing through R0 or R1 (*).

(3) Special Function Registers (SFR), locates from 0080H to 00FFH, can be accessed by direct addressing (*).

(4) 128 Bytes of external SRAM, locates from 0100H to 017FH, can be accessed by instruction MOVX.

(*) Although the SFR and the higher 128 Bytes of internal RAM occupy the same addresses (0080H ~ 00FFH), they are two separate areas. MCU will automatically determine which area is in use by two different accessing ways.

5.3 Flash Memory

The WT56F108 consists of 8K built-in flash, which can be served as general Program memory or simulated E²PROM (0x1800H ~ 0x1EFFH) with features as below:

- ◆ FLASH memory: 8K Bytes
- ◆ Operating voltage: 1.8V ~ 3.6V
- ◆ In-System Programming (ISP)
- ◆ Over 10 years Data Retention
- ◆ Read Out Protection and Code Encryption
- ◆ Emulated E²PROM function @2.4V~3.6V

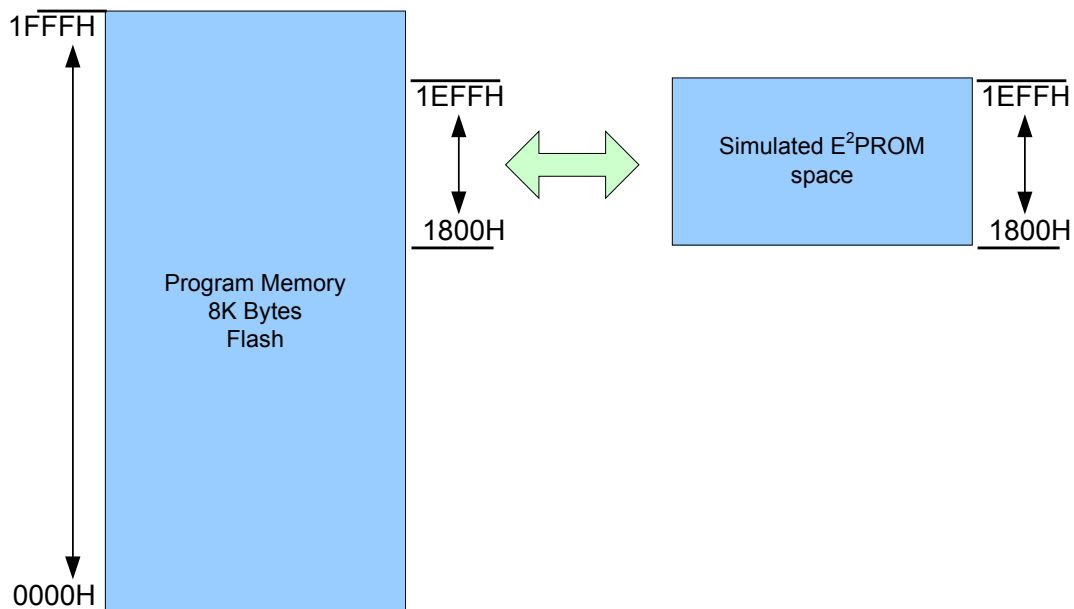

Note: The last 8 bytes of FLASH is Code Option, and the available flash ranges from 0x0000H to 0x1FF7H.

5.4 Memory Mapping

WT56F108 built-in 128 Bytes of direct addressing 8052 standard Special Function Register (SFR), as described below.

- CPU Core Register: ACC, B, PSW, SP, DPL0, DPH0
- Interrupt Register: IP, IE, XICON
- I/O port Register: P0
- Timer Register: TCON, TMOD, TL0, TH0, TL1, TH1, CKCON
- UART0 Register: SCON0, SBUF0, SBRG0H, SBRG0L, PCON

Special Function Register (SFR) MAP:

	Bit Addressable	No Bit Addressable						
F8H								FFH
F0H	B							F7H
E8H								EFH
E0H	ACC							E7H
D8H								DFH
D0H	PSW							D7H
C8H								CFH
C0H	XICON							C7H
B8H	IP							BFH
B0H								B7H
A8H	IE							AFH
A0H								A7H
98H	SCON0	SBUF0	SBRG0H	SBRG0L				9FH
90H								97H
88H	TCON	TMOD	TL0	TL1	TH0	TH1	CKCON	8FH
80H	P0	SP	DPL0	DPH0			PCON	87H

Special Function Register (SFR) Table:

Register Name	Address	Reset Value	Description
P0	80H	FFh	Port 0
SP	81H	07h	Stack Pointer
DPL0	82H	00h	Data Pointer 0 low byte
DPH0	83H	00h	Data Pointer 0 high byte
PCON	87H	00h	Power Control Register
TCON	88H	00h	Timer 0/1 Counter Control
TMOD	89H	00h	Timer 0/1 Mode Control
TL0	8AH	00h	Timer 0, low byte
TL1	8BH	00h	Timer 1, low byte
TH0	8CH	00h	Timer 0, high byte
TH1	8DH	00h	Timer 1, high byte
CKCON	8EH	00h	Timer clock-base select

Register Name	Address	Reset Value	Description
SCON0	98H	00h	Serial Port 0, Control Register
SBUF0	99H	00h	Serial Port 0, Data Buffer
SBRG0H	9AH	00h	Serial Baud rate Generator, high byte
SBRG0L	9BH	00h	Serial Baud rate Generator, low byte
IE	A8H	00h	Interrupt Enable Register
IP	B8H	00h	Interrupt Priority Register 1
XICON	C0H	00h	Interrupt Enable Register (INT3)
PSW	D0H	00h	Program Status Word
ACC	E0H	00h	Accumulator
B	F0H	00h	B Register

Note: Refer to 5.7 “Reset” section for the initial value of SFR.

Introduction of WT56F108 CPU SFR is as below:

B: Address: F0H **Reset Value: 00h**

7	6	5	4	3	2	1	0
B.7	B.6	B.5	B.4	B.3	B.2	B.1	B.0

The B register is used during multiply and divide operations. It can store the multiplier and the high bytes of operation result in multiply operation, and also the divisor and the remainder of operation result in divide operation. The B register can be used as a general register.

ACC: Address: E0H **Reset Value: 00h**

7	6	5	4	3	2	1	0
ACC.7	ACC.6	ACC.5	ACC.4	ACC.3	ACC.2	ACC.1	ACC.0

ACC is the Accumulator register, used for data operations.

P0: Address: 80H **Reset Value: FFh**

7	6	5	4	3	2	1	0
				P0.3	P0.2	P0.1	P0.0

Data setting of Output/Input port P0.

CKCON: Address: 8EH **Reset Value: 00h**

7	6	5	4	3	2	1	0
						TCS1	TCS0

TCS1 = 0: Timer 1 counts once every 12 clocks

TCS1 = 1: Timer 1 counts once every 3 clocks

TCS0 = 0: Timer 0 counts once every 12 clocks

TCS0 = 1: Timer 0 counts once every 3 clocks

PSW (Program Status Word): Address: D0H
Reset Value: 00h

7	6	5	4	3	2	1	0
CY	AC	F0	RS1	RS0	OV	F1	PARITY

The Program Status Word contains program status information.

Bit Number	Bit Mnemonic	Description
7	CY	Carry Flag, used to indicate the result of arithmetic operation whether a carry or borrow occurred in the 7th bit. Operation result of Addition: CY = 1: a carry occurred; CY = 0: no carry occurred. Operation result of Subtraction: CY = 1: a borrow occurred; CY = 0: no borrow occurred.
6	AC	Auxiliary-Carry Flag, used to indicate the result of arithmetic operation whether the 3rd bit borrow (or carry) from the 4th bit occurred. Operation result of Addition: AC = 1: a carry occurred; AC = 0: no carry occurred. Operation result of Subtraction: AC = 1: a carry occurred; AC = 0: no carry occurred.
5	F0	General purpose flag, can be served as common read/write bit.
4	RS1	Register Bank Select bits 1 and 0 (refer to Register Bank Selection Table).
3	RS0	
2	OV	Overflow Flag, used to indicate the result of arithmetic operation whether an overflow occurred. If OV = 1, an overflow occurred. Otherwise, it is cleared.
1	F1	General-purpose flag, can be served as common read/write bit.
0	P	Parity Flag. It is set to indicate an odd number of "1" bits in the accumulator. Otherwise, it is cleared.

Register Bank Selection Table:

Register Bank	Address	RS1	RS0
0	00H ~ 07H	0	0
1	08H ~ 0FH	0	1
2	10H ~ 17H	1	0
3	18H ~ 1FH	1	1

SP (Stack Point) Address: 81H
Reset Value: 07h

7	6	5	4	3	2	1	0
SP.7	SP.6	SP.5	SP.4	SP.3	SP.2	SP.1	SP.0

Stack Pointer, indicated the location at which the last byte was pushed onto the stack. It is incremented before data is stored during PUSH.

DPL0 (DPTR0, low byte of the 16-bit data pointer 0) Address: 82H
Reset Value: 00h

7	6	5	4	3	2	1	0
DPL0.7	DPL0.6	DPL0.5	DPL0.4	DPL0.3	DPL0.2	DPL0.1	DPL0.0

DPL0 is a low byte of DPTR0, using together with the data pointer of DPH0.

DPH0 (DPTR0, high byte of the 16-bit data pointer 0) Address: 83H

Reset Value: 00h

7	6	5	4	3	2	1	0
DPH0.7	DPH0.6	DPH0.5	DPH0.4	DPH0.3	DPH0.2	DPH0.1	DPH0.0

DPH0 is a high byte of DPTR0, using together with the data pointer of DPL0.

Note: Other special function registers will be discussed in later sections.

5.5 In-System Programming (ISP) (Important!!! Must Read!!!)

In-System Programming function allows users to perform programming on the target board directly without removing any components.

ISP interface adopts:

3-wire: VDD, GND (VSS), SWUT

2-wire: SWUT, GND (VSS), if the target board already has VDD power.

The figure below illustrates pins of ISP interface:

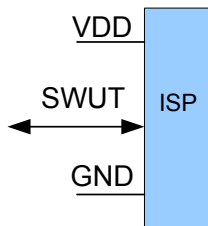

Note: See WT56F108 WLINK-SWUT ISP User's Manual for more details.

5.5.1 In-System Programming Notice

Condition: MCU SOURCE clock 2~16 MHz (Internal/External Oscillator). For more details, please refer to Chapter 8 Application Circuits.

Description: Because this series of MCU adopts single-wire UART (SWUT) for system programming and the baud rate is 115200 bps, SOURCE clock of MCU must work at 2~16 MHz. In addition, the default setting of MCU is IRC 12 MHz (Source clock /2, MCU works at 6 MHz), and thus direct In-System Programming is supported. It requires adding trigger or wakeup conditions if MCU works at external 1 MHz, Green Mode, Idle Mode or Sleep Mode, otherwise programming procedures will fail. The following section will explain how to operate in those modes. (For more details on ISP reference clock sources, please refer to section 3.1.)

RESET/SWUT pin supports Reset/Programming function at the same time, but each level is different. Please refer to the table below.

Function (V _{DD} = 3.3V)	VIH	VIL	Function (V _{DD} = 2.4V)	VIH	VIL
SWUT	0.79 VDD	0.60 VDD	SWUT	0.77 VDD	0.54 VDD
NRST	0.42 VDD	0.20 VDD	NRST	0.47 VDD	0.22 VDD

Normal Mode:

If MCU works at 2~16 MHz (Internal/External Oscillator) and MCU performs Power On Reset normally, the programming process can go smoothly.

MCU works together with special frequency External Oscillator, such as 1 MHz, 32.768 kHz crystal oscillator. It requires setting ISP Clock Source Control Register (ISP_CHG_CTL) to enable two control bits (Bit7 ISP_CHG_12M & Bit5 UART_ISP_CHG), which allows SWUT pin to receive trigger signal. After the MCU being switched to Internal Oscillator 12 MHz automatically, the programming process will succeed. For more details, please refer to section 6.7.

Green Mode:

It is so-called Green Mode when MCU works at 32 kHz (Internal/External Oscillator). MCU cannot perform programming directly when works at this mode. It requires setting ISP Clock Source Control Register (ISP_CHG_CTL) to enable two control bits (Bit7 ISP_CHG_12M & Bit5 UART_ISP_CHG), which allows SWUT pin to receive trigger signal. After the MCU being switched to Internal Oscillator 12 MHz automatically, the programming process will succeed. For more details, please refer to section 6.7.

Idle Mode:

Before entering this mode, in addition to setting ISP Clock Source Control Register (ISP_CHG_CTL) to enable two control bits (Bit7 ISP_CHG_12M & Bit5 UART_ISP_CHG), be sure to set up wakeup conditions. Then MCU can switch back to work at 12 MHz, and maintain 2 ~ 3 seconds to receive the programming command from SWUT. For more details, please refer to section 6.7.

Sleep Mode:

Before entering this mode, in addition to setting ISP Clock Source Control Register (ISP_CHG_CTL) to enable two control bits (Bit7 ISP_CHG_12M & Bit5 UART_ISP_CHG), be sure to set up wakeup conditions. Then MCU can switch back to work at 12 MHz, and maintain 2 ~ 3 seconds to receive the programming command from SWUT. For more details, please refer to section 6.7.

Recommended Circuit:

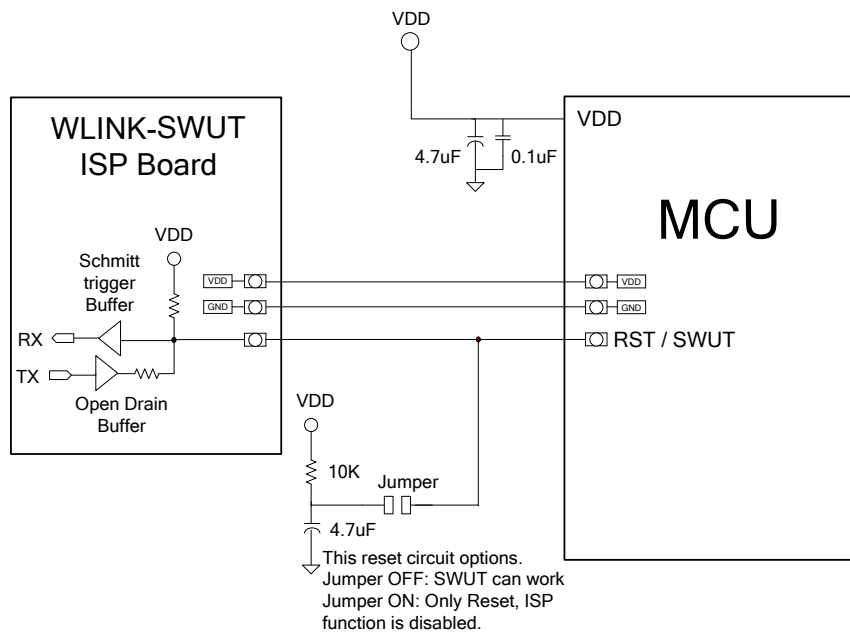

5.6 Timer/Counter

The WT56F108 contains two 16-bit Timer/Counters (Timer0 ~ 1). Both Timer/Counters can be configured as Timer or Counter.

The internal Timer/Counter 0 and Timer/Counter 1 of WT56F108 have four operation modes to be selected by bits M11, M10, or M01, M00 respectively in the Special Function Register TMOD, as described below.

TMOD (8052 Timer0/1 mode control register) Address: 89H

7	6	5	4	3	2	1	0
GATE1	C1/T1	M11	M10	GATE0	C0/T0	M01	M00

Bit Number	Bit Mnemonic	Description
7	GATE1	GATE1 = 1, invalid GATE1 = 0, configured as internal Timer. If TR1 = 1, Timer1 starts.
6	C1/T1	Timer/Counter 1 selector C1/T1 = 1, invalid C1/T1 = 0, configured as an internal Timer, and the counter signal is from MCU Clock 12 MHz IRC ÷ 12
5-4	M11-M10	Timer/Counter 1 mode selection bits 00: Mode 0, 13-bit Timer/Counter 01: Mode 1, 16-bit Timer/Counter 10: Mode 2, 8-bit auto-reload Timer/Counter 11: Mode 3, Timer/Counter 1 stopped and retained count
3	GATE0	GATE0 = 1, invalid GATE0 = 0, configured as internal Timer. If TR0 = 1, Timer0 starts.
2	C0/T0	Timer/Counter 0 selector C0/T0 = 1, invalid C0/T0 = 0, configured as an internal Timer, and the counter signal is from MCU Clock 12 MHz IRC ÷ 12
1-0	M01-M00	Timer/Counter 0 mode selection bits 00: Mode 0, 13-bit Timer/Counter 01: Mode 1, 16-bit Timer/Counter 10: Mode 2, 8-bit auto-reload Timer/Counter 11: Mode 3, 8-bit Timer/Counter (TL0 uses TR0 bit and TH0 uses TR1 bit)

Note: When use Timer/Counter 0 & Timer/Counter1, Cx/Tx must be set as “0” and then Timer/Counter can work normally.

TCON (8052 Timer 0/1 control register) Address: 88H

7	6	5	4	3	2	1	0
TF1	TR1	TF0	TR0	-	-	-	-

Bit Number	Bit Mnemonic	Description
7	TF1	Timer/Counter 1 Overflow Flag. When the Timer/Counter overflows, TF1 is set (TF1 = 1). When CPU is jumped to the Interrupt Service Routine of Timer/Counter 1, TF1 is auto-cleared (TF1 = 0).
6	TR1	Timer/Counter 1 Enable bit. If TR1 is set (TR1 = 1), Timer/Counter 1 is in use; If TR1 is disabled (TR1 = 0), Timer/Counter 1 stopped.

Bit Number	Bit Mnemonic	Description
5	TF0	Timer/Counter 0 Overflow Flag. When the Timer/Counter overflows, TF0 is set (TF0 = 1). When the CPU is jumped to the Interrupt Service Routine of Timer/Counter 0, TF0 is auto-cleared (TF0 = 0).
4	TR0	Timer/Counter 0 Enable bit. If TR0 is set (TR0=1), Timer/Counter 0 is in use; If TR0 is disabled (TR0=0), Timer/Counter 0 stopped.
3-0	-	Invalid

Note: See section 6.4 for more information on Baud rate generator of Timer/Counter 1.

Mode 0:

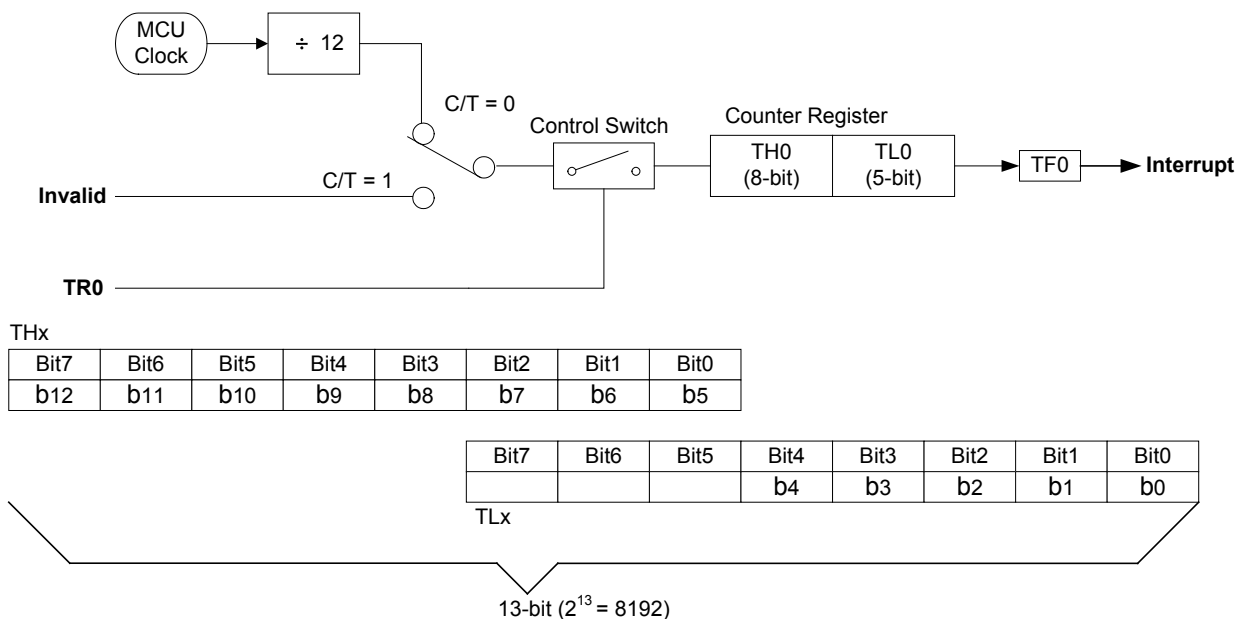

Mode 0 operation is the same for Timer/Counter 0 and Timer/Counter 1. In this mode, the timer register is configured as a 13-bit Up Timer/Counter, which consists of the Special Function Register THx and TLx. As the count of the 13 bits is all 1s, if the register incremented 1 then count of the 13 bits is all 0s and meantime if the Timer/Counter Interrupt is enabled, an Timer overflow interrupt will occur and Overflow Flag is set (TFx = 1, and TFx locates in TCON of the Special Function Register).

Mode 1:

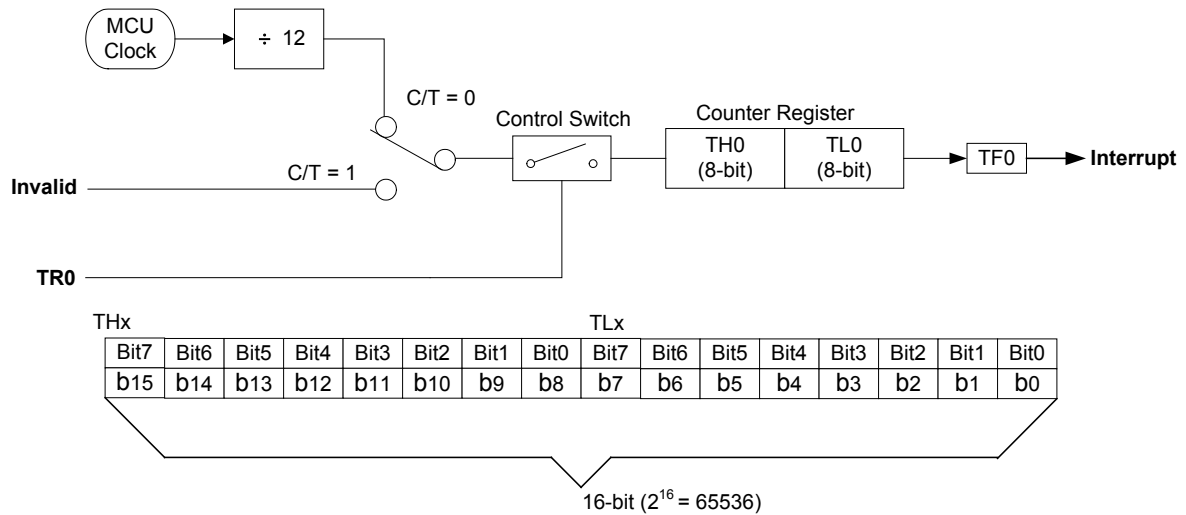

Mode 1 operation is the same as Mode 0 for Timer/Counter 0 and Timer/Counter 1, except that the Timer Register which consists of THx and TLx is configured as a 16-bit Up Timer/Counter.

Mode 2:

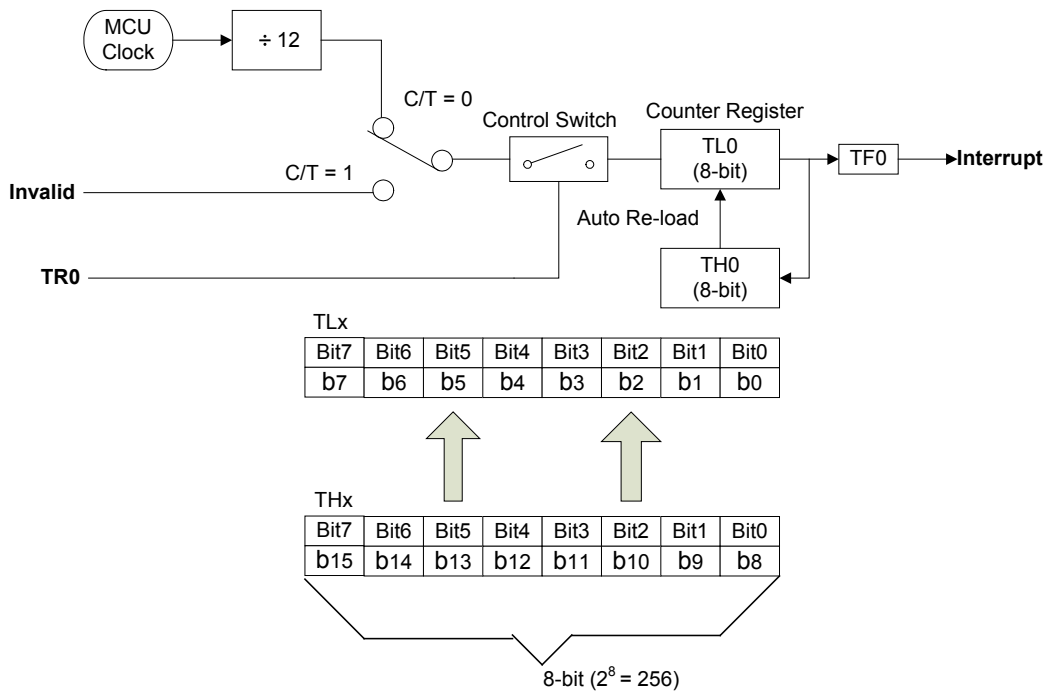

Mode 2 operation is the same for Timer/Counter 0 and Timer/Counter 1 to configure two 8-bit auto-reload Timer/Counters. The counter value is stored in TLx Register. Overflow from TLx not only sets TFx = 1, but also auto-reloads contents of THx to TLx.

Mode 3:

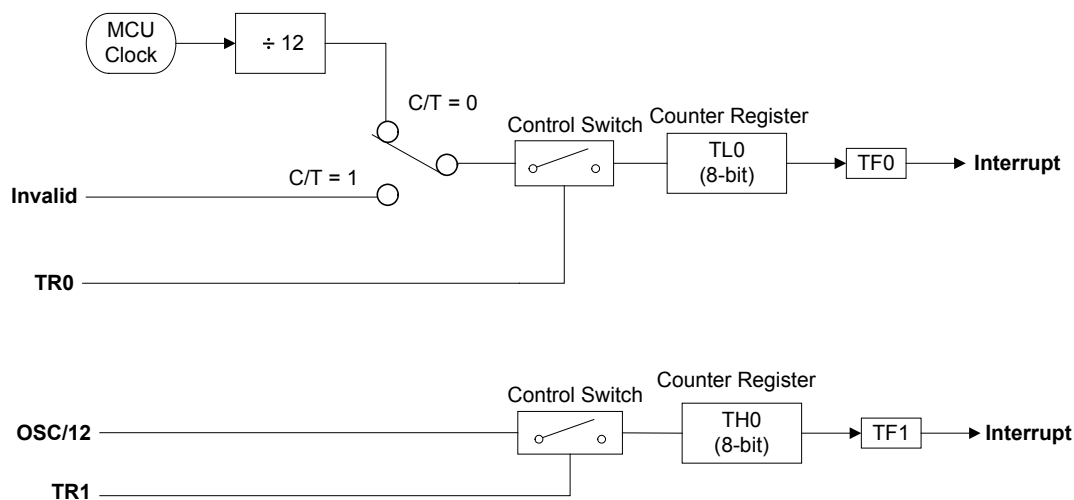

Mode 3 operation is rarely different for Timer/Counter 0 and Timer/Counter 1, as described below. In Mode 3, TL0 is an 8-bit Timer/Counter, while TH0 is an 8-bit Counter controlled by TR1. In the meantime, be aware of the Overflow Flag of Timer/Counter 1 borrowed by TH0, and the corresponding Interrupt Service Routine address is 001BH. In Mode 3, Timer/Counter 1 stopped and retained count.

5.7 Reset

The WT56F108 has seven reset generation sources: Power On Reset (POR), Low Voltage Reset (LVR), Low Voltage Detection Reset (LVDR), External NRST pin Reset Flag, Watchdog Reset, ISP/ICE Command Reset, and PC Counter Overflow Reset (PC_OVR). During Reset, almost all registers are reset to their initial values. You may judge what kind of reset is generated by Reset Flag Register (XFR 0x03).

Power-on Reset (POR)

The Power-on Reset occurs when the VDD supply voltage is below the Power-on Reset voltage threshold (refer to DC Characteristics sections for more details), then XFR: 0x03 POR_RST_FLG = 1.

Low Voltage Reset (LVR)

A reset occurs when the VDD voltage is below the operating voltage threshold, then XFR: 0x03 LVR_RST_FLG = 1.

Low Voltage Detection Reset (LVDR)

A reset occurs when the VDD voltage is below the Low Voltage Detection setting level, then XFR: 0x03 LVD_RST_FLG = 1.

External NRST pin Reset

A reset occurs when the voltage of the external reset pin (NRST) is below its VIL (refer to DC characteristics sections for more details), then XFR: 0x03 NRST_FLG = 1.

Watchdog Timer Reset

A reset occurs when the Watchdog Timer times out, then XFR: 0x03 WDT_RST_FLG = 1.

ISP/ICE Command Reset

An ISP/ICE reset occurs when SWUT pin transmitted the reset command, then XFR: 0x03 ISP_RST_FLG = 1.

PC Counter Overflow Reset (PC_OVR)

The PC counter stores the address where the current instruction locates. A reset occurs when the address exceeds the range of the Flash memory (Flash Address 0x0000 ~ 0x1FFF), then XFR: 0x03 PC_OVL_RST_FLG = 1.

Reset status

When above condition occurred, all Special Function Registers are set to their initial values. SFR contents are described in the following text. XFR contents will be discussed in next section.

The initial value of Special Function Register after Reset (as shown below):

SFR	Initial Value	SFR	Initial Value
P0	11111111b	SCON0	00000000b
SP	00000111b	SBUF0	00000000b
DPL0	00000000b	SBRG0H	00000000b

SFR	Initial Value	SFR	Initial Value
DPH0	00000000b	SBRG0L	00000000b
PCON	00000000b	IE	00000000b
TCON	00000000b	IP	xx000000b
TMOD	00000000b	PSW	00000000b
TL0	00000000b	ACC	00000000b
TL1	00000000b	B	00000000b
TH0	00000000b	XICON	00000000b
TH1	00000000b	CKCON	00000000b

5.8 System Clock and Clock sources

The WT56F108 contains two clock sources: DC ~ 16 MHz external crystal oscillator, and internal 12 MHz RC oscillator. The MCU clock sources are selected by External Special Function Register (XFR) SOURCE_CLK_SLT[1:0] and MCU_CLK_SLT[1:0]. The initial value is internal 12 MHz RC oscillator and Source Clock/2, at the same time MCU works at 6 MHz operating frequency. For more details, refer to section 6.7 Power Management.

Clock Sources are listed below.

Main Clock Sources	Sub Clock Sources
DC ~ 16 MHz Crystal Oscillator	32K Internal RC Oscillator
12 MHz Internal RC Oscillator	32K Internal RC Oscillator
12 MHz Internal RC Oscillator	32.768 kHz Crystal Oscillator

6. Enhanced Function

6.1 External Special Function Register (XFR)

External Special Function Register (XFR) locates from 0x00 to 0xFF, must be accessed by the execution of MOVX instruction. It does not support MOVX @R0,A、MOVX A,@R0, and C language does not support the use of data.

External Special Function Register table:

External memory address	Description
0000H ~ 000DH	System Register and Reset Register
0010H ~ 001FH	General-purpose I/O port Register
0020H ~ 002FH	General-purpose I/O port Register and Multi-function Register
0030H ~ 003FH	Interrupt Enable Register
0040H ~ 004FH	External Interrupt Request Register (IRQ)
0050H ~ 005FH	Pulse Width Modulation Register (PWM)
0060H ~ 006FH	Wakeup Register
0070H ~ 007FH	Internal Oscillator Calibration Register, Watchdog Register, Watch Timer Register
0080H ~ 00A7H	LCD Driver Display Register
00A8H ~ 00AFH	LCD Driver Register
00B0H ~ 00BFH	Enhanced Timer/Counter Register
00D0H ~ 00D7H	10-bit Analog/Digital Register
00E0H ~ 00EFH	Simulated E ² PROM Register

When the Reset status which is mentioned in section 5.7 occurred, the default value of external function register after reset is listed below:

Register Name	Address	Reset Default (Hex)	Index Section
Reserved	-	-	-
System Control Register	0x01	80	6.9
Low Voltage Detection Reset Control Register	0x02	A0	6.13
Reset Flag Register	0x03	01	6.13
ISP Clock Source Control Register	0x04	00	6.7
System Clock Source Control Register	0x05	A1	6.7
Power Saving Control Register	0x06	50	6.7
Clock Source Control Register	0x07	A2	6.7
Oscillator Driver Control Register	0x08	58	6.7
External Clock Source Prescaler Control Register 1	0x09	01	6.9
External Clock Source Prescaler Control Register 2	0x0A	76	6.9
Customer Code Register	0x0D	FF	6.15
General-purpose I/O Port A Output Enable Control Register	0x10	00	6.2
General-purpose I/O Port B Output Enable Control Register	0x11	00	6.2
General-purpose I/O Port C Output Enable Control Register	0x12	00	6.2
General-purpose I/O Port D Output Enable Control Register	0x13	00	6.2
General-purpose I/O Port E Output Enable Control Register	0x14	00	6.2

Register Name	Address	Reset Default (Hex)	Index Section
General-purpose I/O port F Output Enable Control Register	0x15	00	6.2
General-purpose I/O port G Output Enable Control Register	0x16	00	6.2
General-purpose I/O Port A Data Register	0x17	00	6.2
General-purpose I/O Port B Data Register	0x18	00	6.2
General-purpose I/O Port C Data Register	0x19	00	6.2
General-purpose I/O Port D Data Register	0x1A	00	6.2
General-purpose I/O Port E Data Register	0x1B	00	6.2
General-purpose I/O Port F Data Register	0x1C	00	6.2
General-purpose I/O Port G Data Register	0x1D	00	6.2
General-purpose I/O Port A Enable Internal Pull-up Resistor Register	0x1E	FF	6.2
General-purpose I/O Port B Enable Internal Pull-up Resistor Register	0x1F	FF	6.2
General-purpose I/O Port C, D, E, F, G Enable Internal Pull-up Resistor Register	0x20	F8	6.2
General-purpose I/O Port A Output Type Control Register	0x22	FF	6.2
General-purpose I/O Port B Output Type Control Register	0x23	FF	6.2
General-purpose I/O Port A Complex Function Setting Register 1	0x25	00	6.2
General-purpose I/O Port A Complex Function Setting Register 2	0x26	00	6.2
General-purpose I/O Port B Complex Function Setting Register 1	0x27	00	6.2
General-purpose I/O Port B Complex Function Setting Register 2	0x28	00	6.2
General-purpose I/O Port C Complex Function Setting Register	0x29	00	6.2
General-purpose I/O Port D Complex Function Setting Register	0x2A	00	6.2
General-purpose I/O Port E Complex Function Setting Register	0x2B	00	6.2
General-purpose I/O Port F Complex Function Setting Register 1	0x2C	00	6.2
General-purpose I/O Port F Complex Function Setting Register 2	0x2D	00	6.2
General-purpose I/O Port G Complex Function Setting Register	0x2E	00	6.2
8052 External Interrupt 0 Control Register	0x30	00	6.3
8052 External Interrupt 1 Control Register	0x31	00	6.3
8052 External Interrupt 3 Control Register	0x34	00	6.3
8052 External Interrupt 0 (INT0) Flag Register	0x35	00	6.3
8052 External Interrupt 1 (INT1) Flag Register	0x36	00	6.3
8052 External Interrupt 3 (INT3) Flag Register	0x39	00	6.3
External Interrupt Request (IRQ) Control Register	0x40	00	6.5
External Interrupt Request (IRQ) Status Register	0x41	00	6.5
External Interrupt Request (IRQ) Clear Register	0x42	00	6.5
External Interrupt Request (IRQ) Bi-directional Trigger Register	0x43	00	6.5
External Interrupt Request (IRQ) Trigger Edge Register	0x44	00	6.5
PWM Control Register	0x50	00	6.6

Register Name	Address	Reset Default (Hex)	Index Section
PWM0 Period Control High Bytes Register	0x51	00	6.6
PWM0 Period Control Low Bytes Register	0x52	01	6.6
PWM0 Duty Cycle Control High Bytes Register	0x53	00	6.6
PWM0 Duty Cycle Control Low Bytes Register	0x54	00	6.6
PWM1 Period Control High Bytes Register	0x55	00	6.6
PWM1 Period Control Low Bytes Register	0x56	01	6.6
PWM1 Duty Cycle Control High Bytes Register	0x57	00	6.6
PWM1 Duty Cycle Control Low Bytes Register	0x58	00	6.6
General-purpose I/O Port Wakeup Control Register 1	0x60	00	6.7
General-purpose I/O Port Wakeup Control Register 2	0x61	00	6.7
Peripheral Interrupt Wakeup Control Register	0x64	00	6.7
General-purpose I/O Port Wakeup Flag Register 1	0x65	00	6.7
General-purpose I/O Port Wakeup Flag Register 2	0x66	00	6.7
Peripheral Interrupt Wakeup Flag Register	0x69	00	6.7
Wakeup Clear Register	0x6A	00	6.7
Internal Oscillator Adjust Register	0x70	40	6.8
Internal Oscillator Counter Data High Bytes Register	0x71	00	6.8
Internal Oscillator Counter Data Low Bytes Register	0x72	00	6.8
Internal Oscillator Calibration Control Register	0x73	00	6.8
Watchdog Timer Control Register	0x78	02	6.9
Watch Timer Control Register	0x7C	80	6.9
Watch Timer Output Selection Register	0x7D	00	6.9
LCD Driver Display Data Register 0	0x80	00	6.10
LCD Driver Display Data Register 1	0x81	00	6.10
LCD Driver Display Data Register 2	0x82	00	6.10
LCD Driver Display Data Register 3	0x83	00	6.10
LCD Driver Display Data Register 4	0x84	00	6.10
LCD Driver Display Data Register 5	0x85	00	6.10
LCD Driver Display Data Register 6	0x86	00	6.10
LCD Driver Display Data Register 7	0x87	00	6.10
LCD Driver Display Data Register 8	0x88	00	6.10
LCD Driver Display Data Register 9	0x89	00	6.10
LCD Driver Display Data Register 10	0x8A	00	6.10
LCD Driver Display Data Register 11	0x8B	00	6.10
LCD Driver Display Data Register 12	0x8C	00	6.10
LCD Driver Display Data Register 13	0x8D	00	6.10
LCD Driver Display Data Register 14	0x8E	00	6.10

Register Name	Address	Reset Default (Hex)	Index Section
LCD Driver Display Data Register 15	0x8F	00	6.10
LCD Driver Display Data Register 16	0x90	00	6.10
LCD Driver Display Data Register 17	0x91	00	6.10
LCD Driver Display Data Register 18	0x92	00	6.10
LCD Driver Display Data Register 19	0x93	00	6.10
LCD Driver Display Data Register 20	0x94	00	6.10
LCD Driver Display Data Register 21	0x95	00	6.10
LCD Driver Display Data Register 22	0x96	00	6.10
LCD Driver Display Data Register 23	0x97	00	6.10
LCD Driver Display Data Register 24	0x98	00	6.10
LCD Driver Display Data Register 25	0x99	00	6.10
LCD Driver Display Data Register 26	0x9A	00	6.10
LCD Driver Display Data Register 27	0x9B	00	6.10
LCD Driver Display Data Register 28	0x9C	00	6.10
LCD Driver Display Data Register 29	0x9D	00	6.10
LCD Driver Display Data Register 30	0x9E	00	6.10
LCD Driver Display Data Register 31	0x9F	00	6.10
LCD Driver Display Data Register 32	0xA0	00	6.10
LCD Driver Display Data Register 33	0xA1	00	6.10
LCD Driver Display Data Register 34	0xA2	00	6.10
LCD Driver Display Data Register 35	0xA3	00	6.10
LCD Driver Display Data Register 36	0xA4	00	6.10
LCD Driver Display Data Register 37	0xA5	00	6.10
LCD Driver Display Data Register 38	0xA6	00	6.10
LCD Driver Display Data Register 39	0xA7	00	6.10
LCD Driver Control Register 1	0xA8	00	6.10
LCD Driver Control Register 2	0xA9	00	6.10
LCD Driver Segment Output Enable Register 1	0xAB	00	6.10
LCD Driver Segment Output Enable Register 2	0xAC	00	6.10
LCD Driver Segment Output Enable Register 3	0xAD	00	6.10
LCD Driver Segment Output Enable Register 4	0xAE	00	6.10
LCD Driver Segment Output Enable Register 5	0xAF	00	6.10
Enhanced Timer/Counter Control Register	0xB0	00	6.11
Enhanced Timer/Counter Interrupt Register	0xB2	00	6.11
Enhanced Timer/Counter Data Buffer Low Bytes Register	0xB3	00	6.11
Enhanced Timer/Counter Data Buffer High Bytes Register	0xB4	80	6.11
ADC Control Register	0xD0	80	6.12

Register Name	Address	Reset Default (Hex)	Index Section
ADC Setting Control Register	0xD1	40	6.12
ADC Interrupt Control Register	0xD2	00	6.12
ADC Channel Control Register	0xD3	00	6.12
ADC Voltage Compare Data High Bytes Register	0xD4	80	6.12
ADC Voltage Compare Data Low Bytes Register	0xD5	00	6.12
ADC Converted Data High Bytes Register	0xD6	00	6.12
ADC Converted Data Low Bytes Register	0xD7	00	6.12
EPROM Enable Register 1	0xE0	00	6.14
EPROM Enable Register 2	0xE1	00	6.14
EPROM Address Low Bytes Register	0xE2	FF	6.14
EPROM Address High Bytes Register	0xE3	07	6.14
EPROM Control Register	0xE4	00	6.14
EPROM Data Register	0xE8	00	6.14

6.2 I/O Port

6.2.1 Features

- ◆ 56 programmable I/O, contains: GPIOA[7:0], GPIOB[7:0], GPIOC[7:0], GPIOD[7:0], GPIOE[7:0], GPIOF[3:0], and GPIOG[7:0]
- ◆ Some I/O with special functions (such as LCD, ADC, and PWM etc.), can be configured by Special Function Register

6.2.2 Register

WT56F108 I/O related registers are classified into four categories:

- ◆ GPIOx_OE: Control Output/Input Register, configured to set I/O as output or input. If the corresponding bit GPIOx_OE = 1, it is an output port with 4 mA driving ability
- ◆ GPIOx_D: Data Register, reading I/O data or set output of I/O
- ◆ GPIOx_PHN: Internal Pull-up resistor Enable Register. When I/O is configured as Input port (by GPIOx_OE), this register is allowed to set if I/O is with pull-up resistor. If the corresponding GPIOx_PHN bit = 0, the I/O is with internal pull-up resistor. The internal pull-up Resistor Enable Register of the General-purpose I/O port C~G is the same register, each bit defines one I/O port.
- ◆ GPIOx_TYP: Output mode setting Register, is configured to set I/O as Push-Pull or Open-Drain type. Only GPIOA[7:0], or GPIOB[7:0] is allowed to set output type while others are push-pull type.

General-purpose I/O Port A Output Enable Control Register GPIOA_OE (XFR: 0x10)

Reset Value: 00h

Bit	Bit 7	Bit 6	Bit 5	Bit 4	Bit 3	Bit 2	Bit 1	Bit 0
Status	R/W	R/W	R/W	R/W	R/W	R/W	R/W	R/W
Name	GPIOA_OE[7:0]							

Bit Number	Bit Mnemonic	Description
7-0	GPIOA_OE[7:0]	General-purpose I/O Port A Output/Input setting 1: output 0: input (default)

General-purpose I/O Port B Output Enable Control Register GPIOB_OE (XFR: 0x11)

Reset Value: 00h

Bit	Bit 7	Bit 6	Bit 5	Bit 4	Bit 3	Bit 2	Bit 1	Bit 0
Status	R/W	R/W	R/W	R/W	R/W	R/W	R/W	R/W
Name	GPIOB_OE[7:0]							

Bit Number	Bit Mnemonic	Description
7-0	GPIOB_OE[7:0]	General-purpose I/O Port B Output/Input setting 1: output 0: input (default)

General-purpose I/O Port C Output Enable Control Register GPIOC_OE (XFR: 0x12)

Reset Value: 00h

Bit	Bit 7	Bit 6	Bit 5	Bit 4	Bit 3	Bit 2	Bit 1	Bit 0
Status	R/W	R/W	R/W	R/W	R/W	R/W	R/W	R/W
Name	GPIOC_OE[7:0]							

Bit Number	Bit Mnemonic	Description
7-0	GPIOC_OE[7:0]	General-purpose I/O Port C Output/Input setting 1: output 0: input (default)

General-purpose I/O Port D Output Enable Control Register GPIOD_OE (XFR: 0x13)
Reset Value: 00h

Bit	Bit 7	Bit 6	Bit 5	Bit 4	Bit 3	Bit 2	Bit 1	Bit 0
Status	R/W	R/W	R/W	R/W	R/W	R/W	R/W	R/W
Name	GPIOD_OE[7:0]							

Bit Number	Bit Mnemonic	Description
7-0	GPIOD_OE[7:0]	General-purpose I/O Port D Output/Input setting 1: output 0: input (default)

General-purpose I/O Port E Output Enable Control Register GPIOE_OE (XFR: 0x14)
Reset Value: 00h

Bit	Bit 7	Bit 6	Bit 5	Bit 4	Bit 3	Bit 2	Bit 1	Bit 0
Status	R/W	R/W	R/W	R/W	R/W	R/W	R/W	R/W
Name	GPIOE_OE[7:0]							

Bit Number	Bit Mnemonic	Description
7-0	GPIOE_OE[7:0]	General-purpose I/O Port E Output/Input setting 1: output 0: input (default)

General-purpose I/O Port F Output Enable Control Register GPIOF_OE (XFR: 0x15)
Reset Value: 00h

Bit	Bit 7	Bit 6	Bit 5	Bit 4	Bit 3	Bit 2	Bit 1	Bit 0
Status	R/W	R/W	R/W	R/W	R/W	R/W	R/W	R/W
Name	GPIOF_OE[7:0]							

Bit Number	Bit Mnemonic	Description
7-0	GPIOF_OE[7:0]	General-purpose I/O Port F Output/Input setting 1: output 0: input (default)

- : unimplemented.

General-purpose I/O port G Output Enable Control Register GPIOG_OE (XFR: 0x16)
Reset Value: 00h

Bit	Bit 7	Bit 6	Bit 5	Bit 4	Bit 3	Bit 2	Bit 1	Bit 0
Status	R/W	R/W	R/W	R/W	R/W	R/W	R/W	R/W
Name	GPIOG_OE[7:0]							

Bit Number	Bit Mnemonic	Description
7-0	GPIOG_OE[7:0]	General-purpose I/O Port G Output/Input setting 1: output

Bit Number	Bit Mnemonic	Description
		0: input (default)

General-purpose I/O Port A Data Register GPIOA_D (XFR: 0x17)
Reset Value: 00h

Bit	Bit 7	Bit 6	Bit 5	Bit 4	Bit 3	Bit 2	Bit 1	Bit 0
Status	R/W	R/W	R/W	R/W	R/W	R/W	R/W	R/W
Name	GPIOA_D[7:0]							

Bit Number	Bit Mnemonic	Description
7-0	GPIOA_D[7:0]	General-purpose I/O Port A Output/Input data

General-purpose I/O Port B Data Register GPIOB_D (XFR: 0x18)
Reset Value: 00h

Bit	Bit 7	Bit 6	Bit 5	Bit 4	Bit 3	Bit 2	Bit 1	Bit 0
Status	R/W	R/W	R/W	R/W	R/W	R/W	R/W	R/W
Name	GPIOB_D[7:0]							

Bit Number	Bit Mnemonic	Description
7-0	GPIOB_D[7:0]	General-purpose I/O Port B Output/Input data

General-purpose I/O Port C Data Register GPIOC_D (XFR: 0x19)
Reset Value: 00h

Bit	Bit 7	Bit 6	Bit 5	Bit 4	Bit 3	Bit 2	Bit 1	Bit 0
Status	R/W	R/W	R/W	R/W	R/W	R/W	R/W	R/W
Name	GPIOC_D[7:0]							

Bit Number	Bit Mnemonic	Description
7-0	GPIOC_D[7:0]	General-purpose I/O Port C Output/Input data

General-purpose I/O Port D Data Register GPIOD_D (XFR: 0x1A)
Reset Value: 00h

Bit	Bit 7	Bit 6	Bit 5	Bit 4	Bit 3	Bit 2	Bit 1	Bit 0
Status	R/W	R/W	R/W	R/W	R/W	R/W	R/W	R/W
Name	GPIOD_D[7:0]							

Bit Number	Bit Mnemonic	Description
7-0	GPIOD_D[7:0]	General-purpose I/O Port D Output/Input data

General-purpose I/O Port E Data Register GPIOE_D (XFR: 0x1B)
Reset Value: 00h

Bit	Bit 7	Bit 6	Bit 5	Bit 4	Bit 3	Bit 2	Bit 1	Bit 0
Status	R/W	R/W	R/W	R/W	R/W	R/W	R/W	R/W
Name	GPIOE_D[7:0]							

Bit Number	Bit Mnemonic	Description
7-0	GPIOE_D[7:0]	General-purpose I/O Port E Output/Input data

General-purpose I/O Port F Data Register GPIOF_D (XFR: 0x1C)
Reset Value: 00h

Bit	Bit 7	Bit 6	Bit 5	Bit 4	Bit 3	Bit 2	Bit 1	Bit 0
Status	R/W	R/W	R/W	R/W	R/W	R/W	R/W	R/W
Name	GPIOF_D[7:0]							

Bit Number	Bit Mnemonic	Description
7-0	GPIOF_D[7:0]	General-purpose I/O Port F Output/Input data

- : unimplemented.

General-purpose I/O Port G Data Register GPIOG_D (XFR: 0x1D)
Reset Value: 00h

Bit	Bit 7	Bit 6	Bit 5	Bit 4	Bit 3	Bit 2	Bit 1	Bit 0
Status	R/W	R/W	R/W	R/W	R/W	R/W	R/W	R/W
Name	GPIOG_D[7:0]							

Bit Number	Bit Mnemonic	Description
7-0	GPIOG_D[7:0]	General-purpose I/O Port G Output/Input data

- : unimplemented.

General-purpose I/O Port A Enable Internal Pull-up Resistor Register GPIOA_PHN (XFR: 0x1E) Reset Value: FFh

Bit	Bit 7	Bit 6	Bit 5	Bit 4	Bit 3	Bit 2	Bit 1	Bit 0
Status	R/W	R/W	R/W	R/W	R/W	R/W	R/W	R/W
Name	GPIOA_PHN[7:0]							

Bit Number	Bit Mnemonic	Description
7-0	GPIOA_PHN[7:0]	Enable General-purpose I/O Port A Pull-up Resistor setting 1: Disable Pull-up Resistor (default) 0: Enable Pull-up Resistor

General-purpose I/O Port B Enable Internal Pull-up Resistor Register GPIOB_PHN (XFR: 0x1F) Reset Value: FFh

Bit	Bit 7	Bit 6	Bit 5	Bit 4	Bit 3	Bit 2	Bit 1	Bit 0
Status	R/W	R/W	R/W	R/W	R/W	R/W	R/W	R/W
Name	GPIOB_PHN[7:0]							

Bit Number	Bit Mnemonic	Description
7-0	GPIOB_PHN[7:0]	Enable General-purpose I/O Port B Pull-up Resistor setting 1: Disable Pull-up Resistor (default) 0: Enable Pull-up Resistor

General-purpose I/O Port C, D, E, F, G Enable Internal Pull-up Resistor Register GPIOCDEFG_PHN (XFR: 0x20)
Reset Value: F8h

Bit	Bit 7	Bit 6	Bit 5	Bit 4	Bit 3	Bit 2	Bit 1	Bit 0
Status	R/W	R/W	R/W	R/W	R/W	-	-	-
Name	GPIOC_PHN	GPIOD_PHN	GPIOE_PHN	GPIOF_PHN	GPIOG_PHN	Reserved		

Bit Number	Bit Mnemonic	Description
7	GPIOC_PHN	Enable General-purpose I/O Port C Pull-up Resistor setting 1: Disable Pull-up Resistor (default) 0: Enable Pull-up Resistor
6	GPIOD_PHN	Enable General-purpose I/O Port D Pull-up Resistor setting 1: Disable Pull-up Resistor (default) 0: Enable Pull-up Resistor
5	GPIOE_PHN	Enable General-purpose I/O Port E Pull-up Resistor setting 1: Disable Pull-up Resistor (default) 0: Enable Pull-up Resistor
4	GPIOF_PHN	Enable General-purpose I/O Port F Pull-up Resistor setting 1: Disable Pull-up Resistor (default) 0: Enable Pull-up Resistor
3	GPIOG_PHN	Enable General-purpose I/O Port G Pull-up Resistor setting 1: Disable Pull-up Resistor (default) 0: Enable Pull-up Resistor
2-0	Reserved	-

- : unimplemented.

General-purpose I/O Port A Output Type Control Register GPIOA_TYP (XFR: 0x22)

Reset Value: FFh

Bit	Bit 7	Bit 6	Bit 5	Bit 4	Bit 3	Bit 2	Bit 1	Bit 0
Status	R/W	R/W	R/W	R/W	R/W	R/W	R/W	R/W
Name	GPIOA_TYP[7:0]							

Bit Number	Bit Mnemonic	Description
7-0	GPIOA_TYP[7:0]	General-purpose I/O Port A output type setting 1: push-pull output type (default) 0: open-drain output type

General-purpose I/O Port B Output Type Control Register GPIOB_TYP (XFR: 0x23)

Reset Value: FFh

Bit	Bit 7	Bit 6	Bit 5	Bit 4	Bit 3	Bit 2	Bit 1	Bit 0
Status	R/W	R/W	R/W	R/W	R/W	R/W	R/W	R/W
Name	GPIOB_TYP[7:0]							

Bit Number	Bit Mnemonic	Description
7-0	GPIOB_TYP[7:0]	General-purpose I/O Port B output type setting 1: push-pull output type (default) 0: open-drain output type

6.2.3 Port Sharing

This is used to set I/O functions, such as PWM, ADC, etc.

General-purpose I/O Port A Complex Function Setting Register1 GPIOA_FUN1 (XFR: 0x25) Reset Value: 00h

Bit	Bit 7	Bit 6	Bit 5	Bit 4	Bit 3	Bit 2	Bit 1	Bit 0
Status	R/W	R/W	-	-	-	R/W	-	-
Name	GPA7_FUN_SLT[1:0]		Reserved			GPA5_FUN_SLT	Reserved	

Bit Number	Bit Mnemonic	Description
7-6	GPA7_FUN_SLT[1:0]	Set GPIOA7D complex function 00: GPIO/ETMIA/IRQ0 (default) 01: RXA, RX of path A of UART (select RXA, and will auto define GPIOA6DH as TXA) 10: Reserved 11: P00 output/input (mapping to 8052 P0.0)
5-3	Reserved	-
2	GPA5_FUN_SLT	Set GPIOA5D complex function 1: MOSCI1 (served as the Crystal oscillator input pin of path 1, will auto define GPIOA4DH as the crystal oscillator output pin (MOSCO1) instead of GPIO function) 0: GPIO (default), and meanwhile GPIOA4DH will be set as GPIO function. Default value can be selected by section 6.15 Code Option
1-0	Reserved	-

-: unimplemented.

Note 1: The setting of using External Crystal Oscillator as SOURCE clock (using Crystal Oscillator as the input pins of path 1):

1. Select Crystal Oscillator as the input pins of path 1: MOSCI1, MOSCO1. (XFR 0x08 SLT_CRYSTAL = 0)
2. Set GPIOA5 and GPIOA4 as Input port. (XFR 0x10 GPIOA_OE[5:4])
3. GPIOA5 and GPIOA4 disable internal pull high resistor. If enable pull high resistor will result in oscillator outputs unstable frequency. (XFR 0x1E GPIOA_PHN[5:4])
4. Set GPIOA5 and GPIOA4 as Crystal Oscillator pin. (XFR 0x25 GPA5_FUN_SLT)
5. Set the driving ability of External Main Crystal Oscillator. (XFR 0x08 CRY_12M_DR[2:0])
6. Power on External Crystal Oscillator switch. (XFR 0x07 CRY_12M_PD)
7. Switch SOURCE clock to External Crystal Oscillator sources. (XFR 0x05 SOURCE_CLK_SLT[1:0])

Note 2: While using UART or 8052 port, please set the mapping output type of GPIOA_TYP as open-drain and connect to pull-high resistor.

General-purpose I/O Port A Complex Function Setting Register2 GPIOA_FUN2 (XFR: 0x26) Reset Value: 00h

Bit	Bit 7	Bit 6	Bit 5	Bit 4	Bit 3	Bit 2	Bit 1	Bit 0
Status	-	R/W	R/W	R/W	R/W	R/W	R/W	R/W
Name	Reserved	GPA3_FUN_SLT	GPA2_FUN_SLT[1:0]	GPA1_FUN_SLT[1:0]	GPA0_FUN_SLT[1:0]			

Bit Number	Bit Mnemonic	Description
7	Reserved	-
6	GPA3_FUN_SLT	Set GPIOA3DH complex function 1: PWM0B, PWM0 output of path B 0: GPIO/ETMIB/IRQ1 (default)
5-4	GPA2_FUN_SLT[1:0]	Set GPIOA2DH complex function 00: GPIO/IRQ2 (default) 01: VREF, ADC reference voltage input 10: PWM0A, PWM0 output of path A 11: P01 output/input (mapping to 8052 P0.1)
3-2	GPA1_FUN_SLT[1:0]	Set GPIOA1DH complex function 00: GPIO/IRQ3/ETMIC (default) 01: ADC11, ADC analog input 10: PWM1A, PWM1 output of path A 11: P02 output/input (mapping to 8052 P0.2)
1-0	GPA0_FUN_SLT[1:0]	Set GPIOA0DH complex function 00: GPIO/IRQ4 (default) 01: ADC10, ADC analog input 10: ETMO, Enhanced Timer comparing result output 11: P03 output/input (mapping to 8052 P0.3)

-: unimplemented.

Note: While using 8052 port, please set the mapping output type of GPIOA_TYP as open-drain and connect to pull-high resistor.

General-purpose I/O Port B Complex Function Setting Register 1 GPIOB_FUN1 (XFR: 0x27) Reset Value: 00h

Bit	Bit 7	Bit 6	Bit 5	Bit 4	Bit 3	Bit 2	Bit 1	Bit 0
Status	R/W	R/W	-	R/W	-	R/W	R/W	R/W
Name	GPB7_FUN_SLT[1:0]	Reserved	GPB6_FUN_SLT	Reserved	GPB5_FUN_SLT	GPB4_FUN_SLT[1:0]		

Bit Number	Bit Mnemonic	Description
7-6	GPB7_FUN_SLT[1:0]	Set GPIOB7DH complex function 00: GPIO/IRQ5 (default) 01: ADC9, ADC analog input 10: PWM1B, PWM1 output of path B 11: reserved
5	Reserved	-
4	GPB6_FUN_SLT	Set GPIOB6DH complex function 1: ADC8, ADC analog input 0: GPIO (default)
3	Reserved	-

Bit Number	Bit Mnemonic	Description
2	GPB5_FUN_SLT	Set GPIOB5DH complex function 1: ADC7, ADC analog input 0: GPIO/IRQ6 (default)
1-0	GPB4_FUN_SLT[1:0]	Set GPIOB4DH complex function 00: GPIO/IRQ7 (default) 01: ADC6, ADC analog input 10: PWM0C, PWM0 output of path C 11: reserved

-: unimplemented.

General-purpose I/O Port B Complex Function Setting Register2 GPIOB_FUN2 (XFR: 0x28) Reset Value: 00h

Bit	Bit 7	Bit 6	Bit 5	Bit 4	Bit 3	Bit 2	Bit 1	Bit 0
Status	R/W	R/W	-	R/W	-	R/W	-	R/W
Name	GPB3_FUN_SLT[1:0]	Reserved	GPB2_FUN_SLT	Reserved	GPB1_FUN_SLT	Reserved	GPB0_FUN_SLT	

Bit Number	Bit Mnemonic	Description
7-6	GPB3_FUN_SLT[1:0]	Set GPIOB3DH complex function 00: GPIO (default) 01: SEG39, LCD SEG output 10: RXB, RX of path B of UART (select RXB, and the mapping GPIOB2DH must be set as GPIO function) 11: reserved
5	Reserved	-
4	GPB2_FUN_SLT	Set GPIOB2DH complex function 1: SEG38, LCD SEG output 0: GPIO (default) Note: If GPIOB3 = RXB, and the mapping GPIOB2DH must be set as GPIO function.
3	Reserved	-
2	GPB1_FUN_SLT	Set GPIOB1DH complex function 1: SEG37/ADC4, LCD SEG output/ADC analog input 0: GPIO (default)
1	Reserved	-
0	GPB0_FUN_SLT	Set GPIOB0DH complex function 1: SEG36/ADC3, LCD SEG output/ADC analog input 0: GPIO (default)

-: unimplemented.

Note: While using UART, please set the mapping output type of GPIOB_TYP as open-drain and connect to pull-high resistor.

General-purpose I/O Port C Complex Function Setting Register GPIOC_FUN (XFR: 0x29) Reset Value: 00h

Bit	Bit 7	Bit 6	Bit 5	Bit 4	Bit 3	Bit 2	Bit 1	Bit 0
Status	R/W	R/W	R/W	R/W	R/W	R/W	R/W	R/W
Name	GPC_FUN_SLT[7:0]							

Bit Number	Bit Mnemonic	Description
7	GPC7_FUN_SLT	Set GPIOC7 complex function 1: SEG35/ADC2, LCD SEG output / ADC analog input 0: GPIO (default)
6	GPC6_FUN_SLT	Set GPIOC6 complex function 1: SEG34/ADC1, LCD SEG output / ADC analog input 0: GPIO (default)
5	GPC5_FUN_SLT	Set GPIOC5 complex function 1: SEG33/ADC0, LCD SEG output / ADC analog input 0: GPIO (default)
4	GPC4_FUN_SLT	Set GPIOC4 complex function 1: SEG32, LCD SEG output 0: GPIO (default)
3	GPC3_FUN_SLT	Set GPIOC3 complex function 1: SEG31, LCD SEG output 0: GPIO (default)
2	GPC2_FUN_SLT	Set GPIOC2 complex function 1: SEG30, LCD SEG output 0: GPIO (default)
1	GPC1_FUN_SLT	Set GPIOC1 complex function 1: SEG29, LCD SEG output 0: GPIO (default)
0	GPC0_FUN_SLT	Set GPIOC0 complex function 1: SEG28, LCD SEG output 0: GPIO (default)

General-purpose I/O Port D Complex Function Setting Register GPIOD_FUN (XFR: 0x2A) Reset Value: 00h

Bit	Bit 7	Bit 6	Bit 5	Bit 4	Bit 3	Bit 2	Bit 1	Bit 0
Status	R/W	R/W	R/W	R/W	R/W	R/W	R/W	R/W
Name	GPD_FUN_SLT[7:0]							

Bit Number	Bit Mnemonic	Description
7	GPD7_FUN_SLT	Set GPIOD7 complex function 1: SEG27, LCD SEG output 0: GPIO (default)
6	GPD6_FUN_SLT	Set GPIOD6 complex function 1: SEG26, LCD SEG output 0: GPIO (default)
5	GPD5_FUN_SLT	Set GPIOD5 complex function 1: SEG25, LCD SEG output 0: GPIO (default)
4	GPD4_FUN_SLT	Set GPIOD4 complex function 1: SEG24, LCD SEG output 0: GPIO (default)
3	GPD3_FUN_SLT	Set GPIOD3 complex function 1: SEG23, LCD SEG output 0: GPIO (default)
2	GPD2_FUN_SLT	Set GPIOD2 complex function 1: SEG22, LCD SEG output

Bit Number	Bit Mnemonic	Description
		0: GPIO (default)
1	GPD1_FUN_SLT	Set GPIOD1 complex function 1: SEG21, LCD SEG output 0: GPIO (default)
0	GPD0_FUN_SLT	Set GPIOD0 complex function 1: SEG20, LCD SEG output 0: GPIO (default)

General-purpose I/O E Complex Function Setting Register GPIOE_FUN (XFR: 0x2B)

Reset Value: 00h

Bit	Bit 7	Bit 6	Bit 5	Bit 4	Bit 3	Bit 2	Bit 1	Bit 0
Status	R/W	R/W	R/W	R/W	R/W	R/W	R/W	R/W
Name	GPE_FUN_SLT[7:0]							

Bit Number	Bit Mnemonic	Description
7	GPE7_FUN_SLT	Set GPIOE7 complex function 1: SEG19, LCD SEG output 0: GPIO (default)
6	GPE6_FUN_SLT	Set GPIOE6 complex function 1: SEG18, LCD SEG output 0: GPIO (default)
5	GPE5_FUN_SLT	Set GPIOE5 complex function 1: SEG17, LCD SEG output 0: GPIO (default)
4	GPE4_FUN_SLT	Set GPIOE4 complex function 1: SEG16, LCD SEG output 0: GPIO (default)
3	GPE3_FUN_SLT	Set GPIOE3 complex function 1: SEG14, LCD SEG output 0: GPIO (default)
2	GPE2_FUN_SLT	Set GPIOE2 complex function 1: SEG13, LCD SEG output 0: GPIO (default)
1	GPE1_FUN_SLT	Set GPIOE1 complex function 1: SEG12, LCD SEG output 0: GPIO (default)
0	GPE0_FUN_SLT	Set GPIOE0 complex function 1: SEG11, LCD SEG output 0: GPIO (default)

General-purpose I/O Port F Complex Function Setting Register1 GPIOF_FUN1 (XFR: 0x2C)

Reset Value: 00h

Bit	Bit 7	Bit 6	Bit 5	Bit 4	Bit 3	Bit 2	Bit 1	Bit 0
Status	-	R/W	-	R/W	-	R/W	-	R/W
Name	Reserved	GPF7_FUN_SLT	Reserved	GPF6_FUN_SLT	Reserved	GPF5_FUN_SLT	Reserved	GPF4_FUN_SLT

Bit Number	Bit Mnemonic	Description
7	Reserved	-
6	GPF7_FUN_SLT	Set GPIOF7 complex function 1: SEG10, LCD SEG output 0: GPIO (default)
5	Reserved	-
4	GPF6_FUN_SLT	Set GPIOF6 complex function 1: SEG9, LCD SEG output 0: GPIO (default)
3	Reserved	-
2	GPF5_FUN_SLT	Set GPIOF5 complex function 1: SEG8, LCD SEG output 0: GPIO (default)
1	Reserved	-
0	GPF4_FUN_SLT	Set GPIOF4 complex function 1: ADC5, ADC analog input 0: GPIO (default)

:- unimplemented.

General-purpose I/O Port F Complex Function Setting Register2 GPIOF_FUN1 (XFR: 0x2D) Reset Value: 00h

Bit	Bit 7	Bit 6	Bit 5	Bit 4	Bit 3	Bit 2	Bit 1	Bit 0
Status	-	R/W	-	R/W	R/W	R/W	-	R/W
Name	Reserved	GPF3_FUN_SLT	Reserved	GPF2_FUN_SLT	GPF1_FUN_SLT[1:0]		Reserved	GPF0_FUN_SLT

Bit Number	Bit Mnemonic	Description
7	Reserved	-
6	GPF3_FUN_SLT	Set GPIOF3 complex function 1: COM3, LCD Common 3 0: GPIO (default)
5	Reserved	-
4	GPF2_FUN_SLT	Set GPIOF2 complex function 1: COM2, LCD Common 2 0: GPIO (default)
3-2	GPF1_FUN_SLT[1:0]	Set GPIOF1 complex function 00: GPIO (default) 01: COM1, LCD Common 1 10: MOSCO2, served as the Crystal oscillator output pin of path 2, will auto define GPIOF0 as the crystal oscillator input pins (MOSCI2) instead of GPIO function 11: reserved Default value can be selected by section 6.15 Code Option
1	Reserved	-
0	GPF0_FUN_SLT	Set GPIOF0 complex function 1: COM0, LCD Common 0 0: GPIO (default)

-: unimplemented.

Notes: The setting of using External Crystal Oscillator as SOURCE clock (using Crystal Oscillator as the input pins of path 2):

1. Select Crystal Oscillator as the input pins of path 2: MOSCI2, MOSCO2. (XFR 0x08 SLT_CRYSTAL = 1)
2. Set GPIOF1 and GPIOF0 as Input port. (XFR 0x15 GPIOF_OE[1:0])
3. GPIOF1 and GPIOF0 disable internal pull high resistor. If enable pull high resistor will result in oscillator outputs unstable frequency. (XFR 0x20 GPIOF_PHN)
4. Set GPIOF1 and GPIOF0 as Crystal Oscillator pin. (XFR 0x2D GPF1_FUN_SLT[1:0])
5. Set the driving ability of External Main Crystal Oscillator. (XFR 0x08 CRY_12M_DR[2:0])
6. Power on External Crystal Oscillator switch. (XFR 0x07 CRY_12M_PD)
7. Switch SOURCE clock to External Crystal Oscillator. (XFR 0x05 SOURCE_CLK_SLT[1:0])

General-purpose I/O Port G Complex Function Setting Register GPIOG_FUN (XFR: 0x2E) Reset Value: 00h

Bit	Bit 7	Bit 6	Bit 5	Bit 4	Bit 3	Bit 2	Bit 1	Bit 0
Status	R/W	R/W	R/W	R/W	R/W	R/W	R/W	R/W
Name	GPG_FUN_SLT[7:0]							

Bit Number	Bit Mnemonic	Description
7	GPG7_FUN_SLT	Set GPIOG7 complex function 1: SEG7, LCD SEG output 0: GPIO (default)
6	GPG6_FUN_SLT	Set GPIOG6 complex function 1: SEG6, LCD SEG output 0: GPIO (default)
5	GPG5_FUN_SLT	Set GPIOG5 complex function 1: SEG5, LCD SEG output 0: GPIO (default)
4	GPG4_FUN_SLT	Set GPIOG4 complex function 1: SEG4, LCD SEG output 0: GPIO (default)
3	GPG3_FUN_SLT	Set GPIOG3 complex function 1: SEG3, LCD SEG output 0: GPIO (default)
2	GPG2_FUN_SLT	Set GPIOG2 complex function 1: SEG2, LCD SEG output 0: GPIO (default)
1	GPG1_FUN_SLT	Set GPIOG1 complex function 1: SEG1, LCD SEG output 0: GPIO (default)
0	GPG0_FUN_SLT	Set GPIOG0 complex function 1: SEG0, LCD SEG output 0: GPIO (default)

LCD COM pin Setting Table:

COM:

- GPIOF0 (**COM0**)
- GPIOF1 (**COM1**)
- GPIOF2 (**COM2**)
- GPIOF3 (**COM3**)

COM	Register Setting
COM0	0x2D of bit 0: GPF0_FUN_SLT = 1
COM1	0x2D of bit 3-2: GPF1_FUN_SLT[1:0] = 01
COM2	0x2D of bit 4: GPF2_FUN_SLT = 1
COM3	0x2D of bit 6: GPF3_FUN_SLT = 1

LCD SEG pin Setting Table:

SEG:

- GPIOB3 ~ B0 (**SEG39 ~ SEG36**)
- GPIOC7 ~ C0 (**SEG35 ~ SEG28**)
- GPIOD7 ~ D0 (**SEG27 ~ SEG20**)
- GPIOE7 ~ E4 (**SEG19 ~ SEG16**)
- Always **SEG15**
- GPIOE3 ~ E0 (**SEG14 ~ SEG11**)
- GPIOF7 ~ F5 (**SEG10 ~ SEG8**)
- GPIOG7 ~ G0 (**SEG7 ~ SEG0**)

ACOM	Register Setting	BCOM	Register Setting
SEG39	0x28 of bit 7-6: GPB3_FUN_SLT[1:0] = 01	SEG19	0x2B of bit 7: GPE7_FUN_SLT = 1
SEG38	0x28 of bit 4: GPB2_FUN_SLT = 1	SEG18	0x2B of bit 6: GPE6_FUN_SLT = 1
SEG37	0x28 of bit 2: GPB1_FUN_SLT = 1	SEG17	0x2B of bit 5: GPE5_FUN_SLT = 1
SEG36	0x28 of bit 0: GPB0_FUN_SLT = 1	SEG16	0x2B of bit 4: GPE4_FUN_SLT = 1
SEG35	0x29 of bit 7: GPC7_FUN_SLT = 1	SEG15	
SEG34	0x29 of bit 6: GPC6_FUN_SLT = 1	SEG14	0x2B of bit 3: GPE3_FUN_SLT = 1
SEG33	0x29 of bit 5: GPC5_FUN_SLT = 1	SEG13	0x2B of bit 2: GPE2_FUN_SLT = 1
SEG32	0x29 of bit 4: GPC4_FUN_SLT = 1	SEG12	0x2B of bit 1: GPE1_FUN_SLT = 1
SEG31	0x29 of bit 3: GPC3_FUN_SLT = 1	SEG11	0x2B of bit 0: GPE0_FUN_SLT = 1
SEG30	0x29 of bit 2: GPC2_FUN_SLT = 1	SEG10	0x2C of bit 6: GPF7_FUN_SLT = 1
SEG29	0x29 of bit 1: GPC1_FUN_SLT = 1	SEG9	0x2C of bit 4: GPF6_FUN_SLT = 1
SEG28	0x29 of bit 0: GPC0_FUN_SLT = 1	SEG8	0x2C of bit 2: GPF5_FUN_SLT = 1
SEG27	0x2A of bit 7: GPD7_FUN_SLT = 1	SEG7	0x2E of bit 7: GPG7_FUN_SLT = 1
SEG26	0x2A of bit 6: GPD6_FUN_SLT = 1	SEG6	0x2E of bit 6: GPG6_FUN_SLT = 1
SEG25	0x2A of bit 5: GPD5_FUN_SLT = 1	SEG5	0x2E of bit 5: GPG5_FUN_SLT = 1
SEG24	0x2A of bit 4: GPD4_FUN_SLT = 1	SEG4	0x2E of bit 4: GPG4_FUN_SLT = 1
SEG23	0x2A of bit 3: GPD3_FUN_SLT = 1	SEG3	0x2E of bit 3: GPG3_FUN_SLT = 1
SEG22	0x2A of bit 2: GPD2_FUN_SLT = 1	SEG2	0x2E of bit 2: GPG2_FUN_SLT = 1
SEG21	0x2A of bit 1: GPD1_FUN_SLT = 1	SEG1	0x2E of bit 1: GPG1_FUN_SLT = 1
SEG20	0x2A of bit 0: GPD0_FUN_SLT = 1	SEG0	0x2E of bit 0: GPG0_FUN_SLT = 1

ADC Complex Function Setting Table:

ADC	Register Setting	Shared with GPIO
ADC11	GPA1_FUN_SLT[1:0]= 01	GPIOA1
ADC10	GPA0_FUN_SLT[1:0] = 01	GPIOA0
ADC9	GPB7_FUN_SLT[1:0] = 01	GPIOB7
ADC8	GPB6_FUN_SLT = 1	GPIOB6
ADC7	GPB5_FUN_SLT = 1	GPIOB5
ADC6	GPB4_FUN_SLT[1:0] = 01	GPIOB4
ADC5	GPF4_FUN_SLT = 1	GPIOF4
ADC4	GPB1_FUN_SLT = 1	GPIOB1
ADC3	GPB0_FUN_SLT = 1	GPIOB0
ADC2	GPC7_FUN_SLT = 1	GPIOC7
ADC1	GPC6_FUN_SLT = 1	GPIOC6
ADC0	GPC5_FUN_SLT = 1	GPIOC5

ADC VREF Complex Function Setting Table:

ADC VREF	Register Setting	Shared with GPIO
VREF	GPA2_FUN_SLT[1:0] = 01	GPIOA2

Crystal Oscillator Complex Function Setting Table:

CLKIO	Register Setting	Shared with GPIO
MOSCI1	GPA5_FUN_SLT = 1	GPIOA5
MOSCO1	GPA5_FUN_SLT = 1	GPIOA4
MOSCO2	GPF1_FUN_SLT[1:0] = 10	GPIOF1
MOSCI2	GPF1_FUN_SLT[1:0] = 10	GPIOF0

Notes:

If GPIOA5 = MOSCI1, the complex function of GPIOA4 will be invalid, and auto define GPIOA4 as MOSCO1.
 If GPIOF1 = MOSCO2, the complex function of GPIOF0 will be invalid, and auto define GPIOF0 as MOSCI2.

UART Complex Function Setting Table:

UART	Register Setting	Shared with GPIO
RXA	GPA7_FUN_SLT[1:0] = 01	GPIOA7
TXA	GPA7_FUN_SLT[1:0] = 01	GPIOA6
RXB	GPB3_FUN_SLT[1:0] = 10	GPIOB3
TXB	GPB3_FUN_SLT[1:0] = 10	GPIOB2

Notes:

If GPIOA7 = RXA, the complex function of GPIOA6 will be invalid, and auto define GPIOA6 as TXA.
 If GPIOB3 = RXB, the complex function of GPIOB2 will be invalid, and auto define GPIOB2 as TXB.

PWM Complex Function Setting Table:

PWM	Register Setting	Shared with GPIO
PWM0A	GPA2_FUN_SLT[1:0] = 10	GPIOA2
PWM0B	GPA3_FUN_SLT = 1	GPIOA3
PWM0C	GPB4_FUN_SLT[1:0] = 10	GPIOB4
PWM1A	GPA1_FUN_SLT[1:0] = 10	GPIOA1
PWM1B	GPB7_FUN_SLT[1:0] = 10	GPIOB7

6.3 Interrupt

The WT56F108 provides total six 8052 Interrupt sources: three 8052 External Interrupts (INT0, INT1, INT3), two Timer/Counter Interrupt (TF0, TF1), and one UART Interrupt (RI0/TI0).

Each of these interrupt sources has its own enable control bit, and can be individually enabled or disabled by setting or clearing the corresponding bit in the Special Function Register IE.

When an interrupt is generated, CPU will jump to interrupt vector from service routine as listed below. If multiple requests of different priority levels are received simultaneously, the request of higher priority level is serviced, and then returned to service routine through RETI instruction. If interrupt flag bit is set, CPU will enter the Interrupt processing again.

Interrupt Vector Table of 8052 & Priority Level Structure:

Keil C Interrupt Number	Interrupt sources	Vector Address	Priority Level (default)	Interrupt Enable Register
0	8052 external interrupt 0	03H	1	IE.0 (EX0)
1	Timer/Counter 0 interrupt	0BH	2	IE.1 (ET0)
2	8052 external interrupt 1	13H	3	IE.2 (EX1)
3	Timer/Counter 1 interrupt	1BH	4	IE.3 (ET1)
4	Serial port 0 interrupt (UART0)	23H	5	IE.4 (ES)
8	8052 external interrupt 3	43H	9	XICON.6 (EX3)

Interrupt Enable register 0

IE0 (8052 interrupt enable register, including INT0/INT1) Address: A8H

Reset value: 00h

7	6	5	4	3	2	1	0
EA	-	-	ES	ET1	EX1	ET0	EX0

Bit Number	Bit Mnemonic	Description
7	EA	1: Enable all interrupt function 0: Disable all interrupt function
6-5	Reserved	-
4	ES	1: Enable UART 0 interrupt 0: Disable UART 0 interrupt
3	ET1	1: Enable Timer/Counter1 interrupt 0: Disable Timer/Counter1 interrupt
2	EX1	1: Enable 8052 external interrupt 1 interrupt 0: Disable 8052 external interrupt 1 interrupt
1	ET0	1: Enable Timer/Counter0 interrupt 0: Disable Timer/Counter0 interrupt
0	EX0	1: Enable 8052 external interrupt 0 interrupt 0: Disable 8052 external interrupt 0 interrupt

Interrupt Enable register 1
XICON (8052 INT3 interrupt enable register) Address: C0H
Reset value: 00h

7	6	5	4	3	2	1	0
PX3	EX3	IE3	-	-	-	-	-

Bit Number	Bit Mnemonic	Description
7	PX3	Define the interrupt priority of external interrupt 3 1: INT3 has the higher priority 0: INT3 has no higher priority
6	EX3	1: Enable external interrupt 3 interrupt 0: Disable external interrupt 3 interrupt
5	IE3	If CPU detects external interrupt 3 interrupt, IE3 will be cleared by hardware. 1: has external interrupt 3 request 0: no external interrupt 3 request
4-0	Reserved	-

- : unimplemented

Interrupt priority register
IP (8052 interrupt priority register) Address: B8H
Reset value: 00h

7	6	5	4	3	2	1	0
-	-	-	PS	PT1	PX1	PT0	PX0

Bit number	Bit Mnemonic	Description
7-5	Reserved	-
4	PS	Define the interrupt priority of UART 0 1: has the higher priority 0: has the lower priority
3	PT1	Define the interrupt priority of Timer/Counter 1 1: has the higher priority 0: has the lower priority
2	PX1	Define the interrupt priority of external interrupt 1 1: has the higher priority 0: has the lower priority
1	PT0	Define the interrupt priority of Timer/Counter 0 1: has the higher priority 0: has the lower priority
0	PX0	Define the interrupt priority of external interrupt 0 1: has the higher priority 0: has the lower priority

-: unimplemented

As illustrated below, if not set the priority level in Interrupt Priority Register (IP), the priority level of interrupt will be: **INT0 > T0 > INT1 > T1 > UART > INT3**.

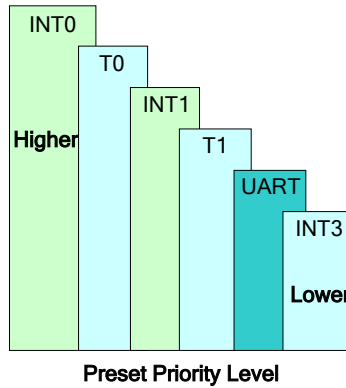

If the higher priority is assigned to any one of the interrupts, such as set PT1 = 1, then the priority level will be: **T1 > INT0 > T0 > INT1 > UART0 > INT3**.

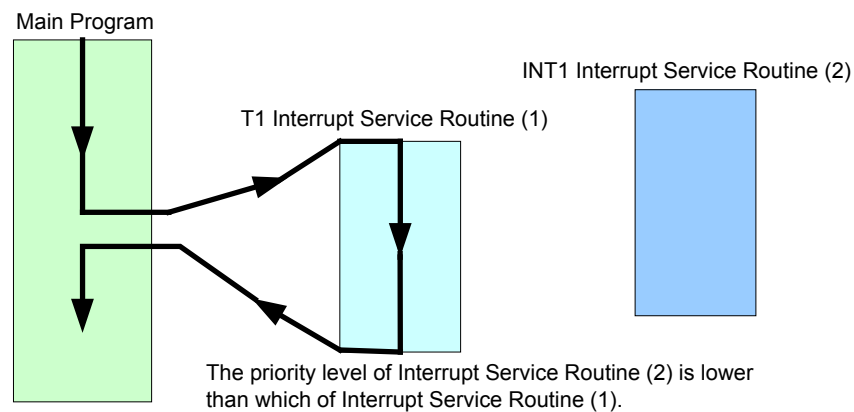

If PT1 = 1 and PX1 = 1, then the priority level will be: **INT1 > T1 > INT0 > T0 > UART0 > INT3**, and so on. The figure below illustrated the executing procedures under different priority levels.

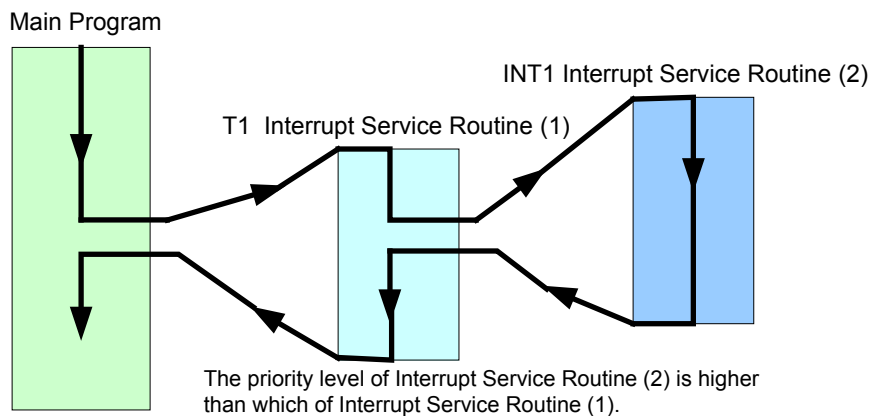

6.3.1 8052 External Interrupt 0/1

The WT56F108 supports four peripheral interrupt sources which are derived from 8052 external interrupt 0/1, as described below.

1. ADC interrupt
2. Watch Timer interrupt
3. Enhanced Timer/Counter interrupt
4. General-purpose I/O port input triggered interrupt

The figure below shows the interrupt sources of 8052 external interrupt 0/1:

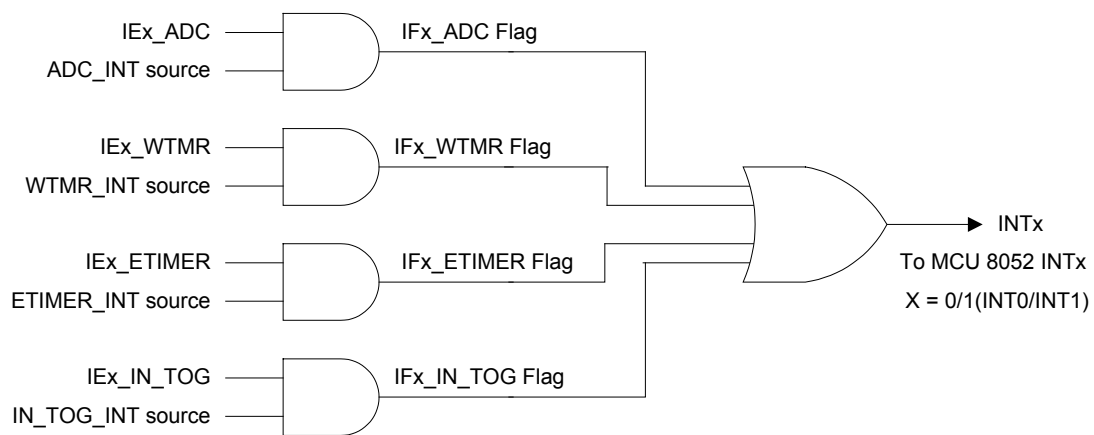

6.3.2 8052 External Interrupt 3

WT56F108 contains 8 External Interrupt Request input pins. An interrupt is generated by using 8052 External Interrupt Vector 3, as illustrated below (refer to section 6.5 for more details).

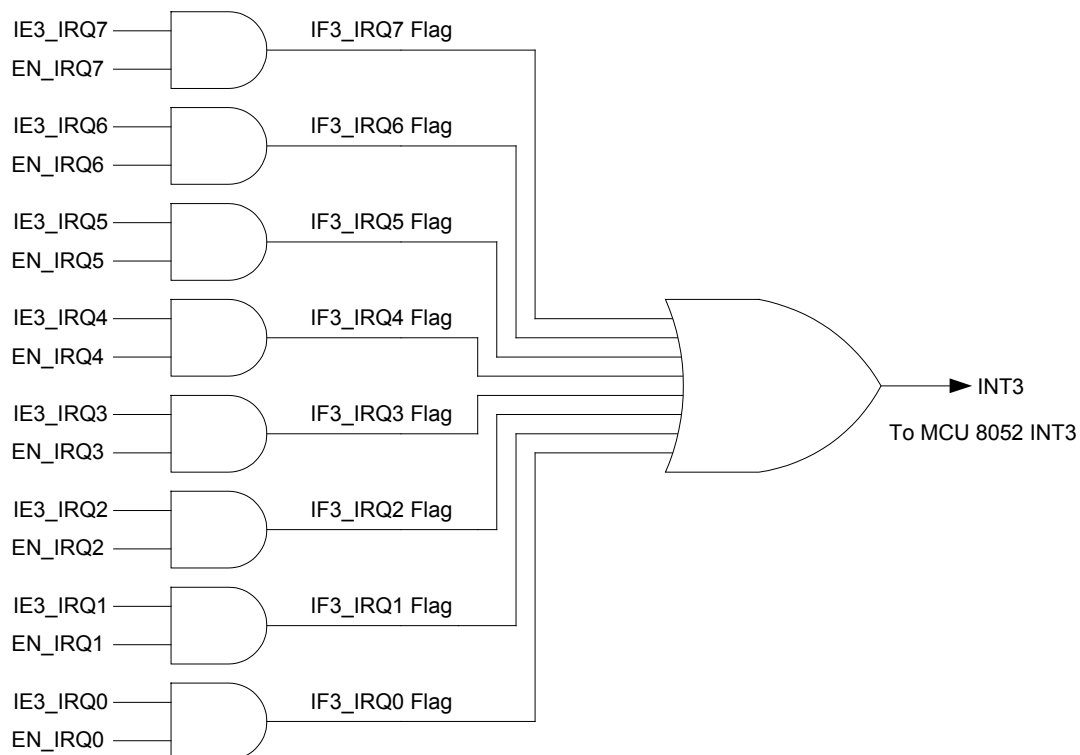

8052 External Interrupt 0 Control Register IE0_CTL (XFR: 0x30)
Reset value: 00h

Bit	Bit 7	Bit 6	Bit 5	Bit 4	Bit 3	Bit 2	Bit 1	Bit 0
Status	-	-	R/W	-	-	R/W	R/W	R/W
Name	Reserved		IE0_ADC	Reserved		IE0_WTMR	IE0_ETIMER	IE0_IN_TOG

Bit Number	Bit Mnemonic	Description
7-6	Reserved	-
5	IE0_ADC	1: Enable ADC Interrupt generated by INT0 0: Disable ADC Interrupt generated by INT0
4-3	Reserved	-
2	IE0_WTMR	1: Enable Watch Timer Interrupt generated by INT0 0: Disable Watch Timer Interrupt generated by INT0
1	IE0_ETIMER	1: Enable Enhanced Timer Interrupt generated by INT0 0: Disable Enhanced Timer Interrupt generated by INT0
0	IE0_IN_TOG	1: Enable All-Input Toggle Interrupt generated by INT0 0: Disable All-Input Toggle Interrupt generated by INT0 GPIO are the 16 GPIOs listed by Registers 0x60 and 0x61.

- : unimplemented

8052 External Interrupt 1 Control Register IE1_CTL (XFR: 0x31)
Reset Value: 00h

Bit	Bit 7	Bit 6	Bit 5	Bit 4	Bit 3	Bit 2	Bit 1	Bit 0
Status	-	-	R/W	-	-	R/W	R/W	R/W
Name	Reserved		IE1_ADC	Reserved		IE1_WTMR	IE1_ETIMER	IE1_IN_TOG

Bit Number	Bit Mnemonic	Description
7-6	Reserved	-
5	IE1_ADC	1: Enable ADC Interrupt generated by INT1 0: Disable ADC Interrupt generated by INT1
4-3	Reserved	-
2	IE1_WTMR	1: Enable Watch Timer Interrupt generated by INT1 0: Disable Watch Timer Interrupt generated by INT1
1	IE1_ETIMER	1: Enable Enhanced Timer Interrupt generated by INT1 0: Disable Enhanced Timer Interrupt generated by INT1
0	IE1_IN_TOG	1: Enable All-Input Toggle Interrupt generated by INT1 0: Disable All-Input Toggle Interrupt generated by INT1 GPIO are the 16 GPIOs listed by Registers 0x60 and 0x61.

- : unimplemented

8052 External Interrupt 3 Control Register INT3_IRQ [7:0] (XFR: 0x34)
Reset Value: 00h

Bit	Bit 7	Bit 6	Bit 5	Bit 4	Bit 3	Bit 2	Bit 1	Bit 0
Status	R/W	R/W	R/W	R/W	R/W	R/W	R/W	R/W
Name	IE3_IRQ[7:0]							

Bit Number	Bit Mnemonic	Description
7	IE3_IRQ7	1: Enable IRQ7 Interrupt generated by INT3 0: Disable IRQ7 Interrupt generated by INT3
6	IE3_IRQ6	1: Enable IRQ6 Interrupt generated by INT3 0: Disable IRQ6 Interrupt generated by INT3
5	IE3_IRQ5	1: Enable IRQ5 Interrupt generated by INT3 0: Disable IRQ5 Interrupt generated by INT3
4	IE3_IRQ4	1: Enable IRQ4 Interrupt generated by INT3 0: Disable IRQ4 Interrupt generated by INT3
3	IE3_IRQ3	1: Enable IRQ3 Interrupt generated by INT3 0: Disable IRQ3 Interrupt generated by INT3
2	IE3_IRQ2	1: Enable IRQ2 Interrupt generated by INT3 0: Disable IRQ2 Interrupt generated by INT3
1	IE3_IRQ1	1: Enable IRQ1 Interrupt generated by INT3 0: Disable IRQ1 Interrupt generated by INT3
0	IE3_IRQ0	1: Enable IRQ0 Interrupt generated by INT3 0: Disable IRQ0 Interrupt generated by INT3

8052 External Interrupt 0 (INT0) Flag Register IF0_FLAG (XFR: 0x35)
Reset Value: 00h

Bit	Bit 7	Bit 6	Bit 5	Bit 4	Bit 3	Bit 2	Bit 1	Bit 0
Status	-	-	R	-	-	R	R	R
Name	Reserved		IF0_ADC	Reserved		IF0_WTMR	IF0_ETIMER	IF0_IN_TOG

Bit Number	Bit Mnemonic	Description
7-6	Reserved	-
5	IF0_ADC	1: ADC Interrupt Event Flag be set, will be cleared automatically after ADC conversion
4-3	Reserved	-
2	IF0_WTMR	1: Watch Timer Interrupt Event Flag be set, Watch Timer Interrupt Flag Clear, refer to section 6.9 XFR[0x7C]
1	IF0_ETIMER	1: Enhanced Timer Interrupt Event Flag be set, Enhanced Timer Interrupt Flag Clear, refer to section 6.12 XFR[0xB2]
0	IF0_IN_TOG	1: All-Input Toggle Interrupt Event Flag be set, Input Toggle Interrupt Flag Clear, refer to section 6.7 XFR[0x6A]

- : unimplemented

8052 External Interrupt 1 (INT1) Flag Register IF1_FLAG (XFR: 0x36)
Reset Value: 00h

Bit	Bit 7	Bit 6	Bit 5	Bit 4	Bit 3	Bit 2	Bit 1	Bit 0
Status	-	-	R	-	-	R	R	R
Name	Reserved		IF1_ADC	Reserved		IF1_WTMR	IF1_ETIMER	IF1_IN_TOG

Bit Number	Bit Mnemonic	Description
7-6	Reserved	-

Bit Number	Bit Mnemonic	Description
5	IF1_ADC	1: ADC Interrupt Event Flag be set, will be cleared automatically after ADC conversion
4-3	Reserved	-
2	IF1_WTMR	1: Watch Timer Interrupt Event Flag be set, Watch Timer Interrupt Flag Clear, refer to section 6.9 XFR[0x7C]
1	IF1_ETIMER	1: Enhanced Timer Interrupt Event Flag be set, Enhanced Timer Interrupt Flag Clear, refer to section 6.12 XFR[0xB2]
0	IF1_IN_TOG	1: All-Input Toggle Interrupt Event Flag be set, Input Toggle Interrupt Flag Clear, refer to section 6.7 XFR[0x6A]

- : unimplemented

8052 External Interrupt 3 (INT3) Flag Register IF3_IRQ [7:0] (XFR: 0x39)
Reset Value: 00h

Bit	Bit 7	Bit 6	Bit 5	Bit 4	Bit 3	Bit 2	Bit 1	Bit 0
Status	R	R	R	R	R	R	R	R
Name	IF3_IRQ[7:0]							

Bit Number	Bit Mnemonic	Description
7	IF3_IRQ7	1: IRQ7 Interrupt Event Flag be set, IRQ Interrupt Flag Clear, refer to section 6.5 XFR[0x42]
6	IF3_IRQ6	1: IRQ6 Interrupt Event Flag be set, IRQ Interrupt Flag Clear, refer to section 6.5 XFR[0x42]
5	IF3_IRQ5	1: IRQ5 Interrupt Event Flag be set, IRQ Interrupt Flag Clear, refer to section 6.5 XFR[0x42]
4	IF3_IRQ4	1: IRQ4 Interrupt Event Flag be set, IRQ Interrupt Flag Clear, refer to section 6.5 XFR[0x42]
3	IF3_IRQ3	1: IRQ3 Interrupt Event Flag be set, IRQ Interrupt Flag Clear, refer to section 6.5 XFR[0x42]
2	IF3_IRQ2	1: IRQ2 Interrupt Event Flag be set, IRQ Interrupt Flag Clear, refer to section 6.5 XFR[0x42]
1	IF3_IRQ1	1: IRQ1 Interrupt Event Flag be set, IRQ Interrupt Flag Clear, refer to section 6.5 XFR[0x42]
0	IF3_IRQ0	1: IRQ0 Interrupt Event Flag be set, IRQ Interrupt Flag Clear, refer to section 6.5 XFR[0x42]

6.4 Universal Asynchronous Receiver-Transmitter (UART)

The WT56F108 contains one Universal Asynchronous Receiver-Transmitter (UART).

As a standard UART of 8052, the Baud rate is selected by the Serial Baud rate Generator in SFR.

On Transmit and Receive, the SFR SBUF0 uses two separate registers: a transmit buffer and a receive buffer register.

Transmitting data: Writing to SBUF0 register and loads these data in serial output buffer, and starts transmitting.

Receiving data: Reading SBUF0 register and reading the serial receive buffer. The serial port can transmit and receive simultaneously. It is also one byte receive-buffered, meaning it can commence reception of a second byte before a previously received byte has been read from the receive register to prevent data loss.

The peripheral registers of UART:

SFR Name	Address	Description
PCON	87H	8052 Power Control Register
SCON0	98H	Serial Port 0, Control Register
SBUF0	99H	Serial Port 0, Data Buffer
SBRG0H	9AH	Serial Baud Rate Generator 0, high byte
SBRG0L	9BH	Serial Baud Rate Generator 0, low byte

UART0 Peripheral Registers

PCON (8052 Power Control Register) Address: 87H

7	6	5	4	3	2	1	0
SMOD1	-	-	-	-	-	-	-

SMOD1: UART0 dual rate bit.

-: unimplemented.

SBUF0 (8052 UART0 buffer) Address: 99H

7	6	5	4	3	2	1	0
SBUF0.7	SBUF0.6	SBUF0.5	SBUF0.4	SBUF0.3	SBUF0.2	SBUF0.1	SBUF0.0

The Serial Data Buffer of UART0. It is used to hold the bytes to be received or the bytes to be transmitted from UART0.

SBRG0H: Address: 9Ah

7	6	5	4	3	2	1	0
SBRG_EN	BRG_M[10]	BRG_M[9]	BRG_M[8]	BRG_M[7]	BRG_M[6]	BRG_M[5]	BRG_M[4]

Used to configure the Baud rate of UART0 and it must be accessed together with SBRG0L.

SBRG0L: Address: 9Bh

7	6	5	4	3	2	1	0
BRG_M[3]	BRG_M[2]	BRG_M[1]	BRG_M[0]	BRG_F[3]	BRG_F[2]	BRG_F[1]	BRG_F[0]

Used to configure the Baud rate of UART0 and it must be accessed together with SBRG0H.

SCON0 (8052 UART0 Control Register) Address: 98H

7	6	5	4	3	2	1	0
SM0_1	SM0_2	SM0_3	REN_0	TB8_0	RB8_0	TI_0	RI_0

Bit Number	Bit Mnemonic	Description
7-6	SM0_1, SM0_2	UART0 mode selection 00: Mode 0 01: Mode 1 10: Mode 2 11: Mode 3
5	SM0_3	Multi-processor Communication Enable bit In Mode 0, if SM0_3 = 0, the multi-processor communication function is disabled. In Mode 1, 2, or 3, if SM0_3 = 1, the multi-processor communication function is enabled.
4	REN_0	UART Receive Enable bit must be cleared by software. REN_0 = 1, receive starts. REN_0 = 0, receive stops.
3	TB8_0	The 9th transmit bit in Mode 2 or Mode 3, can be set or cleared by software.
2	RB8_0	In Mode 0, this bit is invalid. In Mode 1, this bit is Stop bit if SM0_3 = 0 In Mode 2 or 3, the 9th data bit that was received.
1	TI_0	Transmit Interrupt Flag. When an interrupt is complete, this bit will not be restored to "0", and it must be cleared by software. In Mode 0, this bit is set by hardware at the end of the 8th bit, and meantime it can commence a TI_0 interrupt. In Mode 1, 2, or 3, this bit is set by hardware at the end of transmitting Stop bit, and meantime it can commence a TI_0 interrupt.
0	RI_0	Receive Interrupt Flag. When an interrupt is complete, this bit will not be restored to "0", and it must be cleared by software. In Mode 0, this bit is set by hardware at the end of the 8th bit, and meantime it can commence a RI_0 interrupt. In Mode 1, 2, or 3, this bit is set by hardware at the end of transmitting Stop bit, and meantime it can commence a RI_0 interrupt.

The Serial Interface 0 can operate in four modes, as described below.

SM0_1	SM0_2	Mode	Function	Baud Rate
0	0	0	Shift Register	Fosc/12
0	1	1	8-bit UART	Software programmed
1	0	2	8-bit UART	Fosc/32 or Fosc/64
1	1	3	9-bit UART	Software programmed

*Fosc = MCU clock

Mode 0

In Mode 0, the Baud rate of Shift transmission register is fixed at 1/12 of the oscillator frequency ($f_{OSC}/12$). At 12 MHz, the Baud rate is 1Mbps. In this mode, no matter on receive or transmit data, Rx0 of CPUs connects each other worked as a serial data bus and Tx0 connects each other worked as a Shift pulse. On Receive, Tx0 pin sent out the shift pulse, and the serial data is received by Rx0 pin; On Transmit, it is also based on the shift pulse sent by Tx0 pin, and sent the serial data by Rx0 pin.

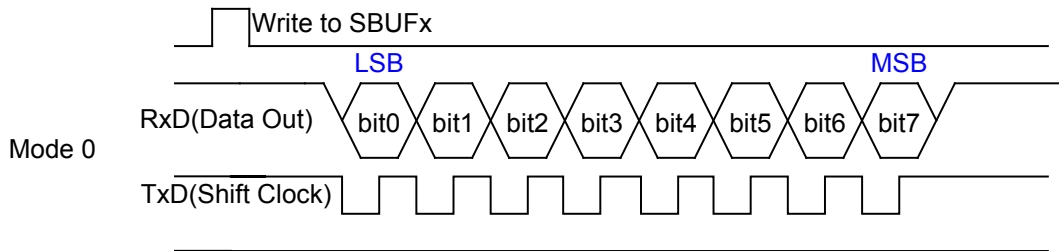

Mode 1

Mode 1 may have a variable Baud rate for serial data transmit, and the Baud rate is controlled by Timer 1. In this mode, the Rx0 pin of WT56F108 connects to the destination TxD pin, and the Tx0 pin of WT56F108 connects to the destination RxD pin.

10 bits are length of transmitted or received: a Start bit, 8 data bits, and a Stop bit. The first bit is the low level start bit (0), followed by the 8 data bits (LSB first, starts from bit 0), then the high level stop bit (1) after bit 7 (MSB).

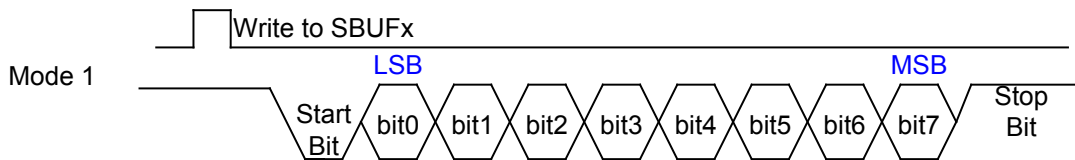

Mode 2

Mode 2 operates at $f_{OSC}/32$ ($SMOD = 1$) or $f_{OSC}/64$ ($SMOD = 0$) for serial data transmission. As for the wire connection, Rx0 pin of WT56F108 connects to destination TxD pin and Tx0 pin of WT56F108 connects to destination RxD pin. 11 bits are length of transmitted or received: a Start bit, 8 data bits, a Parity bit, and 1 Stop bit. The first bit is the low level start bit (0), followed by the 8 data bits (LSB first, starts from bit 0), then the Parity bit after bit 7, and finally the high level stop bit.

On Transmit, TB8_0 in SCON0 is the 9th data bit. The TB8_0 in SCON0 will transmit the 9th data bit; On Receive, the RB8_0 in SCON0 will receive the 9th data bit.

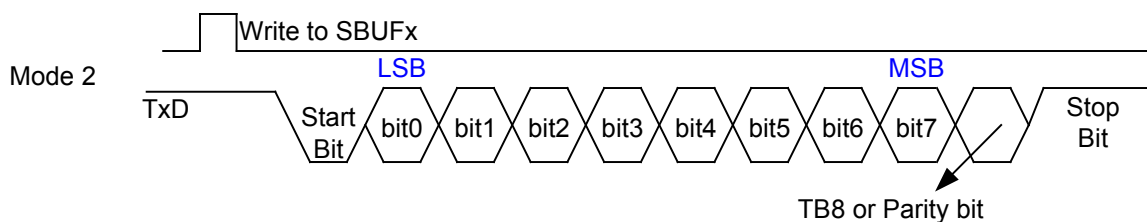

Mode 3

The Baud rate in mode 3 is variable for serial data transmission, and it is controlled by Timer 1. The operation in Mode 3 is the same as Mode 2.

Serial Baud rate of UART0:

SBRG_EN (SBRG0H.7)	SMOD1 (PCON.7)	Baud Rate for UART0
0	0	$\frac{1}{32} \times \frac{f_{osc}}{12 \times (256 - TH1)}$
0	1	$\frac{1}{16} \times \frac{f_{osc}}{12 \times (256 - TH1)}$
1	0	$\frac{f_{osc}}{32 * (BRG_M[10:0] + \frac{BRG_F[3:0]}{16})}$
1	1	$\frac{f_{osc}}{16 * (BRG_M[10:0] + \frac{BRG_F[3:0]}{16})}$

If SBRG_EN (SBRG0H.7) = 1 & SMOD1(PCON.7) = 1

$$\text{UART0 Baud rate} = \frac{f_{osc}}{16 * (BRG_M[10:0] + \frac{BRG_F[3:0]}{16})}$$

Baud rate supporting table:

Bits/sec	12 MHz				Actual	Error
	Baud Rate Register	BRG_M	BRG_F			
600	1250	1250	0	600	0.0%	
1200	625	625	0	1200	0.0%	
2400	312.5	312	8	2400	0.0%	
4800	156.25	156	4	4800	0.0%	
9600	78.125	78	2	9600	0.0%	
14400	52.083	52	1	14405	0.04%	
19200	39.0625	39	1	19200	0.0%	
38400	19.531	19	8	38461	0.16%	
57600	13	13	0	57692	0.16%	
115200	6.5	6	8	115384	0.16%	
230400	3.25	3	4	230769	0.16%	

WT56F108 supports one UART; the UART can select different RX/TX path to prevent the pin being occupied.

UART	Register Setting	Input/output pin
RXA	XFR: 0x25 GPA7_FUN_SLT[1:0] = 01	GPIOA7
TXA		GPIOA6
RXB	XFR: 0x28 GPB3_FUN_SLT[1:0] = 10	GPIOB3
TXB		GPIOB2

6.5 External Interrupt Request (IRQ)

- Supports 8 input Interrupts and built-in digital Filter. (The clock source of digital filter is internal oscillator 12 MHz)
- Supports single-side positive edge-triggered, negative edge-triggered, or positive edge and negative edge triggered simultaneously

Single side triggered:

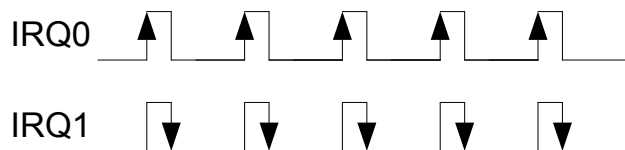

Bidirectional triggered:



External Interrupt Request (IRQ) Control Register EN_IRQ [7:0] (XFR: 0x40)

Reset Value: 00h

Bit	Bit 7	Bit 6	Bit 5	Bit 4	Bit 3	Bit 2	Bit 1	Bit 0
Status	R/W	R/W	R/W	R/W	R/W	R/W	R/W	R/W
Name	EN_IRQ[7:0]							

Bit Number	Bit Mnemonic	Description
7-0	EN_IRQ[7:0]	External Interrupt Request Enable setting. Each bit is corresponded to the related IRQ pin. 1: Enable the External Interrupt Request of the corresponding pins 0: Disable the External Interrupt Request of the corresponding pins

External Interrupt Request (IRQ) Status Register EVT_IRQ [7:0] (XFR: 0x41)

Reset Value: 00h

Bit	Bit 7	Bit 6	Bit 5	Bit 4	Bit 3	Bit 2	Bit 1	Bit 0
Status	R	R	R	R	R	R	R	R
Name	EVT_IRQ[7:0]							

Bit Number	Bit Mnemonic	Description
7-0	EVT_IRQ[7:0]	External Interrupt Request Status. Each bit is corresponded to the related IRQ status. 1: an interrupt trigger occurred in the corresponding pins. 0: an interrupt trigger not occurred in the corresponding pins.

External Interrupt Request (IRQ) Clear Register CLR_IRQ [7:0] (XFR: 0x42)
Reset Value: 00h

Bit	Bit 7	Bit 6	Bit 5	Bit 4	Bit 3	Bit 2	Bit 1	Bit 0
Status	W	W	W	W	W	W	W	W
Name	CLR_IRQ[7:0]							

Bit Number	Bit Mnemonic	Description
7-0	CLR_IRQ[7:0]	External Interrupt Request Clear 1: writing one to the corresponding bits can clear the interrupt status 0: no action

External Interrupt Request (IRQ) Bi-directional Trigger Register IRQ_CHG [7:0] (XFR: 0x43) Reset Value: 00h

Bit	Bit 7	Bit 6	Bit 5	Bit 4	Bit 3	Bit 2	Bit 1	Bit 0
Status	R/W	R/W	R/W	R/W	R/W	R/W	R/W	R/W
Name	IRQ_CHG[7:0]							

Bit Number	Bit Mnemonic	Description
7-0	IRQ_CHG[7:0]	External Interrupt Request Trigger setting 1: Bi-directional triggered 0: Single-side triggered (work together with IRQ_EDGE[7:0] to set positive or negative triggered)

External Interrupt Request (IRQ) Trigger Edge Register IRQ_EDGE [7:0] (XFR: 0x44)
Reset Value: 00h

Bit	Bit 7	Bit 6	Bit 5	Bit 4	Bit 3	Bit 2	Bit 1	Bit 0
Status	R/W	R/W	R/W	R/W	R/W	R/W	R/W	R/W
Name	IRQ_EDGE[7:0]							

Bit Number	Bit Mnemonic	Description
7-0	IRQ_EDGE[7:0]	External Interrupt Request Trigger Edge setting 1: negative edge triggered 0: positive edge triggered

6.6 Pulse Width Modulation (PWM)

WT56F108 provides two 16-bit precise Pulse Width Modulation modules to generate periods and Duty cycles.

- Output Frequency is 65535 levels; frequency range: 6 MHz ~ 183.1 Hz (at IRC 12 MHz)
- The resolutions of Duty and period and Source clock are closely related to each other.

$$\boxed{\text{Source clock}} = 2^{\boxed{\text{Duty resolution}}} \times \boxed{\text{Period}}$$

For example, if Source clock is IRC 12 MHz, Duty Resolution is 10 bit, then the period range is limited within 11.7 kHz.

- Output type: push pull or open drain, can be configured by GPIOx_TYP[x] (GPIOA2, GPIOA3, GPIOB4, GPIOA1, GPIOB7) register.

PWM Control Register PWM_CTL (XFR: 0x50)

Reset Value: 00h

Bit	Bit 7	Bit 6	Bit 5	Bit 4	Bit 3	Bit 2	Bit 1	Bit 0
Status	-	-	R/W	R/W	-	R/W	R/W	R/W
Name	Reserved		PWM_PLRTY[1:0]		Reserved	LBYTE_UPD_EN	PWM_EN[1:0]	

Bit Number	Bit Mnemonic	Description
7-6	Reserved	-
5-4	PWM_PLRTY[1:0]	Bit 5: 1: PWM1 negative edge output 0: PWM1 positive edge output Bit 4: 1: PWM0 negative edge output 0: PWM0 positive edge output
3	Reserved	-
2	LBYTE_UPD_EN	1: Enable updating PWM output while writing PWM period or Duty Cycle Control Low Bytes Register 0: Disable updating PWM output while writing PWM period or Duty Cycle Control Low Bytes Register
1	PWM_EN[1:0]	1: Enable PWM1 function 0: Disable PWM1 function
0		1: Enable PWM0 function 0: Disable PWM0 function

-: unimplemented.

PWM0 Period Control High Bytes Register PWM0_PRD[15:8] (XFR: 0x51)

Reset Value: 00h

Bit	Bit 7	Bit 6	Bit 5	Bit 4	Bit 3	Bit 2	Bit 1	Bit 0
Status	R/W	R/W	R/W	R/W	R/W	R/W	R/W	R/W
Name	PWM0_PRD[15:8]							

Bit Number	Bit Mnemonic	Description
7-0	PWM0_PRD[15:8]	PWM0_PRD[15:8] sets the output period of PWM0, and which is paired with PWM0_PRD[7:0] to form a 16-bit of period control value. PWM0 period: SOURCE clock/(PWM0_PRD[15:0]+1), source clock: 12 MHz IRC, DC ~ 16 MHz Crystal OSC. 32 kHz IRC and 32.768 kHz Crystal OSC.

PWM0 Period Control Low Bytes Register PWM0_PRD[7:0] (XFR: 0x52) Reset Value: 01h

Bit	Bit 7	Bit 6	Bit 5	Bit 4	Bit 3	Bit 2	Bit 1	Bit 0
Status	R/W	R/W	R/W	R/W	R/W	R/W	R/W	R/W
Name	PWM0_PRD[7:0]							

Bit Number	Bit Mnemonic	Description
7-0	PWM0_PRD[7:0]	PWM0_PRD[7:0] sets the output period of PWM0, and which is paired with PWM0_PRD[15:8] to form a 16-bit of period control value. PWM0 period: SOURCE clock/ (PWM0_PRD[15:0]+1), source clock: 12 MHz IRC, DC ~ 16 MHz Crystal OSC. 32 kHz IRC and 32.768 kHz Crystal OSC.

PWM0 Duty Cycle Control High Bytes Register PWM0_DUTY[15:8] (XFR: 0x53) Reset Value: 00h

Bit	Bit 7	Bit 6	Bit 5	Bit 4	Bit 3	Bit 2	Bit 1	Bit 0
Status	R/W	R/W	R/W	R/W	R/W	R/W	R/W	R/W
Name	PWM0_DUTY[15:8]							

Bit Number	Bit Mnemonic	Description
7-0	PWM0_DUTY[15:8]	Sets the duty cycle output of PWM0. PWM0_DUTY[15:8] sets the duty cycle of PWM0, and is paired with PWM0_DUTY[7:0] to form a 16-bit of duty cycle control value.

Note: The maximum setting of Duty must be a reasonable value.

PWM0 Duty Cycle Control Low Bytes Register PWM0_DUTY[7:0] (XFR: 0x54) Reset Value: 00h

Bit	Bit 7	Bit 6	Bit 5	Bit 4	Bit 3	Bit 2	Bit 1	Bit 0
Status	R/W	R/W	R/W	R/W	R/W	R/W	R/W	R/W
Name	PWM0_DUTY[7:0]							

Bit Number	Bit Mnemonic	Description
7-0	PWM0_DUTY[7:0]	Set the duty cycle output of PWM0 PWM0_DUTY[7:0] sets the duty cycle of PWM0, and is paired with PWM0_DUTY[15:8] to form a 16-bit of duty cycle control value.

Note: The maximum setting of Duty must be a reasonable value.

PWM1 Period Control High Bytes Register PWM1_PRD[15:8] (XFR: 0x55)
Reset Value: 00h

Bit	Bit 7	Bit 6	Bit 5	Bit 4	Bit 3	Bit 2	Bit 1	Bit 0
Status	R/W	R/W	R/W	R/W	R/W	R/W	R/W	R/W
Name	PWM1_PRD[15:8]							

Bit Number	Bit Mnemonic	Description
7-0	PWM1_PRD[15:8]	PWM1_PRD[15:8] sets the output period of PWM1, and is paired with PWM1_PRD[7:0] to form a 16-bit of duty cycle control value. PWM1 period: SOURCE clock/(PWM1_PRD[15:0]+1), source clock: 12 MHz IRC, DC ~ 16 MHz Crystal OSC. 32 kHz IRC and 32.768 kHz Crystal OSC.

PWM1 Period Control Low Bytes Register PWM1_PRD[7:0] (XFR: 0x56)
Reset Value: 01h

Bit	Bit 7	Bit 6	Bit 5	Bit 4	Bit 3	Bit 2	Bit 1	Bit 0
Status	R/W	R/W	R/W	R/W	R/W	R/W	R/W	R/W
Name	PWM1_PRD[7:0]							

Bit Number	Bit Mnemonic	Description
7-0	PWM1_PRD[7:0]	PWM1_PRD[7:0] sets the output period of PWM1, and is paired with PWM1_PRD[15:8] to form a 16-bit of duty cycle control value. PWM1 period: SOURCE clock/(PWM1_PRD[15:0]+1), source clock: 12 MHz IRC, DC ~ 16 MHz Crystal OSC. 32 kHz IRC and 32.768 kHz Crystal OSC.

PWM1 Duty Cycle Control High Bytes Register PWM1_DUTY[15:8] (XFR: 0x57)
Reset Value: 00h

Bit	Bit 7	Bit 6	Bit 5	Bit 4	Bit 3	Bit 2	Bit 1	Bit 0
Status	R/W	R/W	R/W	R/W	R/W	R/W	R/W	R/W
Name	PWM1_DUTY[15:8]							

Bit Number	Bit Mnemonic	Description
7-0	PWM1_DUTY[15:8]	Sets the duty cycle output of PWM1 PWM1_DUTY[15:8] sets the duty cycle of PWM1, and is paired with PWM1_DUTY[7:0] to form a 16-bit of duty cycle control value.

Note: The maximum setting of Duty must be a reasonable value.
PWM1 Duty Cycle Control Low Bytes Register PWM1_DUTY[7:0] (XFR: 0x58)
Reset Value: 00h

Bit	Bit 7	Bit 6	Bit 5	Bit 4	Bit 3	Bit 2	Bit 1	Bit 0
Status	R/W	R/W	R/W	R/W	R/W	R/W	R/W	R/W
Name	PWM1_DUTY[7:0]							

Bit Number	Bit Mnemonic	Description
7-0	PWM1_DUTY[7:0]	Sets the duty cycle of PWM1 PWM1_DUTY[7:0] sets the duty cycle of PWM1, and is paired with PWM1_DUTY[15:8] to form a 16-bit duty cycle control value.

Note: The maximum setting of Duty must be a reasonable value.

PWM0/PWM1 Period Setting example:

$$\text{Period} = \frac{\text{Source clock (if: IRC 12MHz)}}{\text{PWMx_PRD} + 1}$$

PWMx_PRD	PWM output period
1	6 MHz (Max.)
2	4 MHz
3	3 MHz
11	1 MHz
23	500 kHz
59	200 kHz
119	100 kHz
239	50 kHz
599	20 kHz
1199	10 kHz
2399	5 kHz
2999	4 kHz
3999	3 kHz
5999	2 kHz
11999	1 kHz
23999	500 Hz
29999	400 Hz
39999	300 Hz
59999	200 Hz
65535	183.1 Hz (Min.)

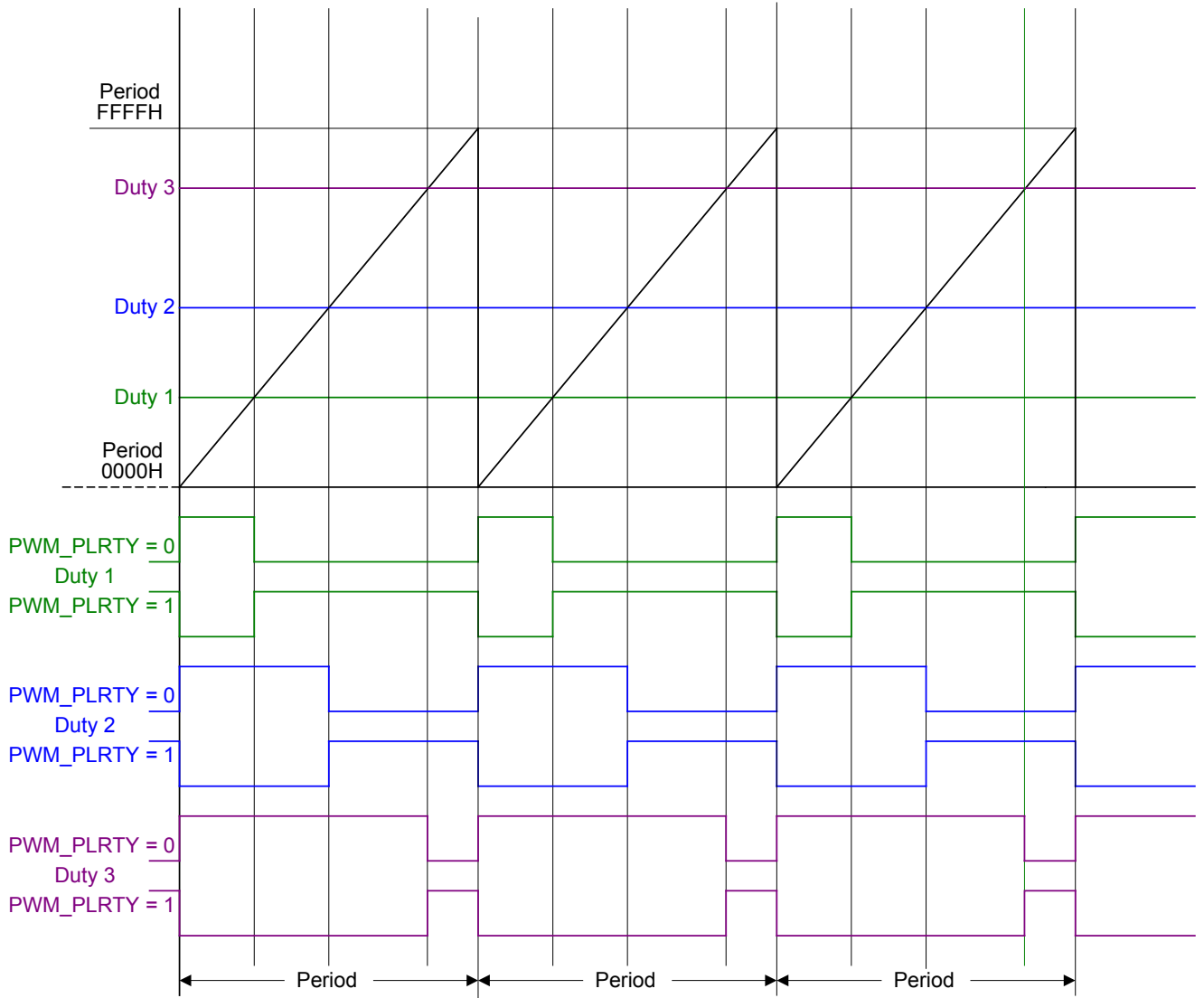

6.7 Power Management

WT56F108 provides four operation modes, as listed below.

- Normal mode
- Green mode
- Idle mode
- Sleep mode

Power Consumption (@ 3V)

	8052	Peripheral Clock	XTAL (high frequency)	XTAL (32768 Hz)	IRC (12 MHz)	IRC (32K)	Power Consumption @3V	Note
Normal 1	on	on	off	off	on	on	6 mA	*1
Normal 2	on	on	off	on	on	on	6 mA	*2
Normal 3	on	on	on	off	off	on	6.2 mA	*3
Green 1	on	on	off	off	off	on	29 uA	*4*6
Green 2	on	on	off	on	off	off	19 uA	*5*6
Idle 1	off	on	off	off	on	on	1.4 mA	*7*9*12
Idle 2	off	off	off	off	on	on	700 uA	*8*9*12
Sleep 1	off	off	off	off	off	off	130 uA	*10*12
Sleep 2	off	off	off	off	off	off	1 uA	*11*12
Sleep 3	off	off	off	on	off	off	5 uA	*13
Sleep 4	off	off	off	off	off	on	10 uA	*14

Notes:

1. LCD power consumption: No Load = 1.8uA @3V

2. LVR/LVDR power consumption is about 18uA@3V

*1 Normal 1 Mode: MCU all use the internal oscillator, and therefore this mode is the most cost-saving mode, but IRC 12 MHz will be affected by the impact of temperature and supply voltage, please refer to section 7.5.

*2 Normal 2 Mode: use external oscillator 32.768 kHz to calibrate IRC 12 MHz. Calibration can reach ±1%.

*3 Normal 3 Mode: this mode is focused on precise high frequency. Calendar or Clock function can only be achieved by 8052 Timer due to without external oscillator 32.768 kHz.

*4 Green 1 Mode: Source clock select internal IRC 32 kHz, but IRC 32 kHz frequency tolerance is ±30%.

*5 Green 2 Mode: Prior to selecting Source clock of External Crystal Oscillator 32.768 kHz, please manually turn on the power of external crystal oscillator (CRY_12M_PD) to allow external crystal oscillator start oscillation. Due to the external crystal oscillator 32.768 kHz with small frequency tolerance, Calendar or Clock function can be achieved by Watch Timer.

*6 Prior to switching back to Normal Mode in Green 1 and Green 2 mode, please turn on IRC_12M_PD2 or CRY_12M_PD first, then select Source clock to work at internal IRC 12 MHz or external 12 MHz.

*7 Idle 1 Mode: Enable MCU_CLK_OFF to enter Idle mode, this mode wakeup fast and support the most wakeup sources, please refer to the next page wakeup source illustration figure.

*8 Idle 2 Mode: Enable SYSTEM_CLK_OFF to enter Idle mode, this mode turn off Peripheral Clock, thus MCU cannot use INT0/1/_WK to wakeup, please refer to the next page wakeup source illustration figure.

- *9 Wakeup time of Idle 1 & Idle 2 Mode: Source clock 12 MHz wakeup time $4 * (1/12 \text{ MHz}) = 333\text{ns}$; Source clock 32 kHz wakeup time $4 * (1/32 \text{ kHz}) = 125\text{us}$
- *10 Sleep 1 Mode.: this mode is about Source clock enable IRC12M_CLK_OFF at IRC 12 MHz, allowing MCU to enter Sleep mode, and support fast Wakeup. The wakeup time is start up + $12 * (1/12 \text{ MHz}) = 1\text{us}$. Please refer to the figure below.
- *11 Sleep 2 Mode.: enable SOURCE_CLK_OFF to enter Sleep mode,
wakeup time: if Source clock is IRC 12 MHz, start up + $132 * (1/12 \text{ MHz}) = 21\text{us}$; if Source clock is external crystal oscillator 12 MHz, $16 * 1024 * (1/12 \text{ MHz}) = 1365\text{us}$. Please refer to the figure below.
- *12 Adopts Watch Timer Wakeup in Idle & Sleep mode, turn on the oscillator Power (IRC_32K_PD or CRY_12M_PD) as the clock source of Watch Timer, in the meantime the power-consumption is increasing.
- *13 Adopts Watch Timer Wakeup in Sleep mode, and turn on the External crystal oscillator power (CRY_12M_PD) as the clock source of Watch Timer.
- *14 Adopts Watch Timer Wakeup in Sleep mode, and turn on the **Internal** crystal oscillator power (IRC_32K_PD) as the clock source of Watch Timer.

MCU Operation Mode figure:

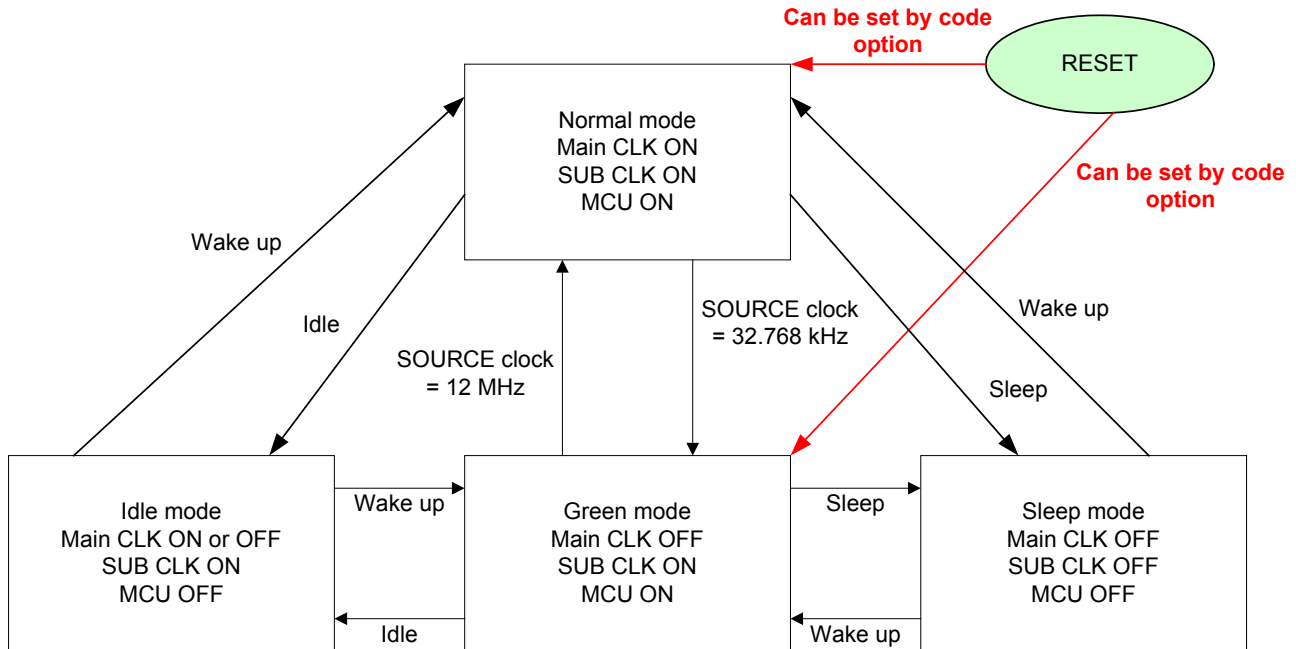

WT56F108 provides many sources of wakeup returning itself from sleep/idle mode to normal mode.

The figure below illustrated the Wakeup sources below each mode:

		Idle 1	Idle 2	Sleep Mode
SOURCE		MCU_CLK_OFF	SYSTEM_CLK_OFF	SOURCE_CLK_OFF IRC12M_CLK_OFF
NRST		●	●	●
GPIOx_WK[x]		●	●	●
INT0/1_WK	IE0/1_ADC			
	IE0/1_WTMR			
	IE0/1_ETIMER	●		
	IE0/1_IN_TOG	●	●	●
INT3_WK	IRQ[7:0]	●		
ADC_WK		●	●	●
WTMR_WK		●	●	●

Notes:

- indicates supporting wakeup
- GPIOx_WK[x] & IE0/1_IN_TOG: only support 16 General-purpose I/O pin Toggle (GPIOA7, A6, A3, A2, A1, A0, B7, B5, B4, B3, B2, E7, E6, E3, E2, E0)
- ADC_WK: based on reference source for compare Toggle wakeup
- WTMR_WK: turn on crystal oscillator (IRC 32 kHz or Ext 32 kHz) and crystal oscillator power to be the clock source of Watch Timer.

ISP Clock Source Control Register ISP_CHG_CTL (XFR: 0x04)
Reset Value: 00h

Bit	Bit 7	Bit 6	Bit 5	Bit 4	Bit 3	Bit 2	Bit 1	Bit 0
Status	R/W	-	R/W	R	-	-	-	-
Name	ISP_CHG_12M	Reserved	UART_ISP_CHG	ISP_CHG_FLAG	Reserved			

Bit Number	Bit Mnemonic	Description
7	ISP_CHG_12M	When MCU is in Green & Sleep mode, ISP pin will turn on the internal 12 MHz RC oscillator automatically. 1: Enable 0: Disable
6	Reserved	-
5	UART_ISP_CHG	UART pin (SWUT) trigger ISP clock source as internal 12 MHz RC oscillator. 1: Enable 0: Disable
4	ISP_CHG_FLAG	ISP_CHG_FLAG = 1: MCU is waken up by SWUT pin. Turn on internal 12 MHz RC oscillator and SOURCE clock switch to 12 MHz. Clear ISP_CHG_FLAG by setting ISP_CHG_12M bit = 0
3-0	Reserved	-

-: unimplemented.

Note: If Source clock is in non-12 MHz application, please add below Forcing Toggle SWUT setting procedure to the program enabling MCU programming repeatedly.

Non 12 MHz mode contains: Green, Sleep mode or use external oscillator (non 12 MHz) can enable ISP_CHG_12M & UART_ISP_CHG bit allow MCU pin trigger to switch the SOURCE clock & ISP clock to internal 12 MHz RC oscillator by SWUT, and meanwhile MCU can receive the correct ISP command.

Mandatory trigger SWUT setting procedures:

1. Program Initialized Enable ISP_CHG_12M & UART_ISP_CHG bit
rISP_CHG_CTL = 0xA0;
2. Program main loop judge if ISP_CHG_FLAG been triggered, and based on Sleep mode to add one software wakeup mechanism, please refer to the example program.

```
void DRV_CheckSwutTriggerWakeup(void)
{
    //If enable rISP_CHG_CTL of bit 7 and Bit.
    //When Swut pin have hi to low(2V) level, Mcu will change source clock to IRC 12 MHz
    if(rISP_CHG_CTL & 0x10)
    {
        DRV_SoftwareWakeup();
        //need delay 100ms(minimum) to wait ISP command, Don't remove this delay command
        DelayWhile(100); //This time MCU change source clock to IRC 12 MHz
        rISP_CHG_CTL = 0x00; //Disable ISP change clock. MCU go back to original setting
        rISP_CHG_CTL = 0xA0; //Enable ISP change clock
    }
}
```

Code Option setting General-purpose I/O Complex Function mapping registers, including Crystal Oscillator pins, Crystal oscillator Source option setting.

System Clock Source Control Register SOURCE_CLK_SLT (XFR: 0x05)
Reset Value: A1h

Bit	Bit 7	Bit 6	Bit 5	Bit 4	Bit 3	Bit 2	Bit 1	Bit 0
Status	-	-	-	-	R/W	R/W	R/W	R/W
Name	Reserved				SOURCE_CLK_SLT[1:0]		MCU_CLK_SLT[1:0]	

Bit Number	Bit Mnemonic	Description
7-4	-	Must be equal to "1010", otherwise bit [3:0] cannot be written into.
3-2	SOURCE_CLK_SLT[1:0]	Select SOURCE clock sources 00: internal 12 MHz RC oscillator (default) 01: external DC ~ 16 MHz crystal oscillator 10: internal 32 kHz RC oscillator 11: reserved Default value can be selected by section 6.15 Code Option
1-0	MCU_CLK_SLT[1:0]	MCU clock setting 00: MCU clock and System clock = SOURCE clock 01: MCU clock and System clock = SOURCE clock /2 (default) 10: MCU clock and System clock = SOURCE clock /4 11: MCU clock and System clock = SOURCE clock /12

-: unimplemented.

Power-saving Control Register POWER_SAVE_CTL (XFR: 0x06)
Reset Value: 50h

Bit	Bit 7	Bit 6	Bit 5	Bit 4	Bit 3	Bit 2	Bit 1	Bit 0
Status	-	-	-	-	R/W	R/W	R/W	R/W
Name	Reserved				MCU_CLK_OFF	SYSTEM_CLK_OFF	SOURCE_CLK_OFF	IRC12M_CLK_OFF

Bit Number	Bit Mnemonic	Description
7-4	-	Must be equal to "0101"; otherwise, Bit[3:0] cannot be written into.
3	MCU_CLK_OFF	1: MCU clock is Off (including MCU and partial peripheral hardware), and MCU must wait for 3~4 MCU clock cycles until MCU clock ON and work. 0: MCU clock is On.
2	SYSTEM_CLK_OFF	1: MCU clock is Off (including MCU and partial peripheral hardware), and MCU must wait for 3~4 MCU clock cycles until system clock ON and work. 0: MCU clock is On.
1	SOURCE_CLK_OFF (bias OFF)	1: SOURCE clock is Off. SOURCE clock sources: (MCU clock is turned off and bias OFF) External 12 MHz or 32.768 kHz crystal oscillator, and MCU must wait for 16*1024 SYSTEM clock cycles until source clock ON and work. Internal 12 MHz oscillator, and MCU must wait for 131~132 SYSTEM clock cycles until source clock ON and work. Internal 32 kHz RC oscillator, and MCU must wait for 8 SYSTEM clock cycles until source clock ON and work. 0: MCU clock is On.

Bit Number	Bit Mnemonic	Description
0	IRC_12M_CLK_OFF (bias ON)	1: Internal 12 MHz RC oscillator is Off and bias ON MCU must wait for 11~12 IRC12M clock cycles until IRC12M ON and work. 0: MCU clock is On.

-: unimplemented.

Note: Refer to section 3.1 System Clock Tree for more details.

Clock Source Control Register IRC_12M_PD (XFR: 0x07)
Reset Value: A2h

Bit	Bit 7	Bit 6	Bit 5	Bit 4	Bit 3	Bit 2	Bit 1	Bit 0
Status	-	-	-	R/W	R/W	R/W	R/W	-
Name	Reserved			IRC_12M_PD1	IRC_12M_PD2	IRC_32K_PD	CRY_12M_PD	Reserved

Bit Number	Bit Mnemonic	Description
7-5	-	Must be equal to "101", otherwise bit[4:0] cannot be written into
4	IRC_12M_PD1	1: partial internal 12 MHz RC oscillator power is turned off (default value is not off) 0: not off Default value can be selected by section 6.15 Code Option
3	IRC_12M_PD2	1: all internal 12 MHz RC oscillator power is turned off (default value is not off) 0: not off Default value can be selected by section 6.15 Code Option
2	IRC_32K_PD	1: internal 32 kHz RC oscillator power is turned off (default value is not off) 0: not off Default value can be selected by section 6.15 Code Option
1	CRY_12M_PD	1: external 12 MHz ~ 32 kHz crystal oscillator power is turned off (default value is off) 0: not off Default value can be selected by section 6.15 Code Option
0	Reserved	-

-: unimplemented.

Oscillator Driver Control Register CRY_12M_DR[2:0] (XFR: 0x08)
Reset Value: 58h

Bit	Bit 7	Bit 6	Bit 5	Bit 4	Bit 3	Bit 2	Bit 1	Bit 0
Status	-	-	-	-	R/W	R/W	R/W	R/W
Name	Reserved				CRY_12M_DR[2:0]			SLT_CRYSTAL

Bit Number	Bit Mnemonic	Description
7-4	-	Must be equal to "0101", otherwise, Bit[3:0] cannot be written into
3-1	CRY_12M_DR[2:0]	External oscillator driving ability setting 000: crystal oscillator with frequency of 32.768 kHz (VDD > 2.4V) 001: crystal oscillator with frequency of 32.768 kHz

Bit Number	Bit Mnemonic	Description
		010: crystal oscillator with frequency of 100 kHz 100: crystal oscillator with frequency of 1 MHz ~ 12 MHz (default) 110: crystal oscillator with frequency of 12 MHz ~ 16 MHz Default value can be selected by section 6.15 Code Option
0	SLT_CRYSTAL	Crystal Oscillator Input pin selection 1: the crystal oscillator input pins of path 2. MOSCI2 (GPIOF0), MOSCO2 (GPIOF1) 0: the crystal oscillator input pins of path 1. MOSCI1 (GPIOA5), MOSCO1 (GPIOA4) Default value can be selected by section 6.15 Code Option

-: unimplemented.

General-purpose I/O Port Wakeup Control Register 1 GPIO_WK[15:8] (XFR: 0x60)

Reset Value: 00h

Bit	Bit 7	Bit 6	Bit 5	Bit 4	Bit 3	Bit 2	Bit 1	Bit 0
Status	R/W	R/W	R/W	R/W	R/W	R/W	R/W	R/W
Name	GPIO_WK[15:8]							

Bit Number	Bit Mnemonic	Description
7-0	GPIO_WK[15:8]	General-purpose I/O Port Wakeup MCU Enable setting Bit 7 = 1: Enable General-purpose I/O Port A7 Wakeup MCU function; 0: function disabled Bit 6 = 1: Enable General-purpose I/O Port A6 Wakeup MCU function; 0: function disabled Bit 5 = 1: Enable General-purpose I/O Port A3 Wakeup MCU function; 0: function disabled Bit 4 = 1: Enable General-purpose I/O Port A2 Wakeup MCU function; 0: function disabled Bit 3 = 1: Enable General-purpose I/O Port A1 Wakeup MCU function; 0: function disabled Bit 2 = 1: Enable General-purpose I/O Port A0 Wakeup MCU function; 0: function disabled Bit 1 = 1: Enable General-purpose I/O Port B7 Wakeup MCU function; 0: function disabled Bit 0 = 1: Enable General-purpose I/O Port B5 Wakeup MCU function; 0: function disabled

General-purpose I/O Port Wakeup Control Register 2 GPIO_WK[7:0] (XFR: 0x61)

Reset Value: 00h

Bit	Bit 7	Bit 6	Bit 5	Bit 4	Bit 3	Bit 2	Bit 1	Bit 0
Status	R/W	R/W	R/W	R/W	R/W	R/W	R/W	R/W
Name	GPIO_WK[7:0]							

Bit Number	Bit Mnemonic	Description
7-0	GPIO_WK[7:0]	General-purpose I/O Port Trigger Wakeup MCU Enable setting Bit 7 = 1: Enable General-purpose I/O Port B4 Trigger Wakeup MCU function; 0: function disabled Bit 6 = 1: Enable General-purpose I/O Port B3 Trigger Wakeup MCU function;

Bit Number	Bit Mnemonic	Description
		0: function disabled Bit 5 = 1: Enable General-purpose I/O Port B2 Trigger Wakeup MCU function; 0: function disabled Bit 4 = 1: Enable General-purpose I/O Port E7 Trigger Wakeup MCU function; 0: function disabled Bit 3 = 1: Enable General-purpose I/O Port E6 Trigger Wakeup MCU function; 0: function disabled Bit 2 = 1: Enable General-purpose I/O Port E3 Trigger Wakeup MCU function; 0: function disabled Bit 1 = 1: Enable General-purpose I/O Port E2 Trigger Wakeup MCU function; 0: function disabled Bit 0 = 1: Enable General-purpose I/O Port E0 Trigger Wakeup MCU function; 0: function disabled

Peripheral Interrupt Wakeup Control Register PERIPHERAL_WK (XFR: 0x64)
Reset Value: 00h

Bit	Bit 7	Bit 6	Bit 5	Bit 4	Bit 3	Bit 2	Bit 1	Bit 0
Status	R/W	-	R/W	R/W	R/W		R/W	-
Name	INT_WK[3:0]			ADC_WK	Reserved	WTMR_WK	Reserved	

Bit Number	Bit Mnemonic	Description
7-4	INT_WK[3:0]	External 8052 INT0/1/3 Wakeup MCU Enable setting Bit 7 = 1: Enable 8052 INT3 Wakeup MCU function; 0: function disabled Bit 6 = reserved Bit 5 = 1: Enable 8052 INT1 Wakeup MCU function; 0: function disabled Bit 4 = 1: Enable 8052 INT0 Wakeup MCU function; 0: function disabled
3	ADC_WK	ADC Wakeup MCU Enable setting 1: Enable Wakeup MCU function after ADC compare is complete 0: Disable Wakeup MCU function after ADC compare is complete
2	Reserved	-
1	WTMR_WK	Watch Timer Wakeup MCU Enable setting 1: Enable Watch Timer Wakeup MCU function after Watch Timer is triggered 0: Disable Watch Timer Wakeup MCU function after Watch Timer is triggered
0	Reserved	-

-: unimplemented.

General-purpose I/O Port Wakeup Flag Register GPIO_TOG[15:8] (XFR: 0x65)
Reset Value: 00h

Bit	Bit 7	Bit 6	Bit 5	Bit 4	Bit 3	Bit 2	Bit 1	Bit 0
Status	R	R	R	R	R	R	R	R
Name	GPIO_TOG[15:8]							

Bit Number	Bit Mnemonic	Description
7-0	GPIO_TOG[15:8]	General-purpose I/O Port Trigger Wakeup Flag. If the corresponding bit Toggle Trigger occurred, Wakeup Flag Bit = 1 Bit 7: I/O Port A7 Wakeup Flag Bit 6: I/O Port A6 Wakeup Flag Bit 5: I/O Port A3 Wakeup Flag Bit 4: I/O Port A2 Wakeup Flag Bit 3: I/O Port A1 Wakeup Flag Bit 2: I/O Port A0 Wakeup Flag Bit 1: I/O Port B7 Wakeup Flag Bit 0: I/O Port B5 Wakeup Flag

General-purpose I/O Port Wakeup Flag Register GPIO_TOG[7:0] (XFR: 0x66)
Reset Value: 00h

Bit	Bit 7	Bit 6	Bit 5	Bit 4	Bit 3	Bit 2	Bit 1	Bit 0
Status	R	R	R	R	R	R	R	R
Name	GPIO_TOG[7:0]							

Bit Number	Bit Mnemonic	Description
7-0	GPIO_TOG[7:0]	General-purpose I/O Port Trigger Wakeup Flag. If the corresponding bit Toggle Trigger occurred, Wakeup Flag Bit = 1 Bit 7: I/O Port B4 Wakeup Flag Bit 6: I/O Port B3 Wakeup Flag Bit 5: I/O Port B2 Wakeup Flag Bit 4: I/O Port E7 Wakeup Flag Bit 3: I/O Port E6 Wakeup Flag Bit 2: I/O Port E3 Wakeup Flag Bit 1: I/O Port E2 Wakeup Flag Bit 0: I/O Port E0 Wakeup Flag

Peripheral Interrupt Wakeup Flag Register PERIPHERAL_TOG (XFR: 0x69)
Reset Value: 00h

Bit	Bit 7	Bit 6	Bit 5	Bit 4	Bit 3	Bit 2	Bit 1	Bit 0
Status	R	-	R	R	R	-	R	-
Name	INT_WK_EVT[3:0]			ADC_TOG	Reserved	WTMR_EVT	Reserved	

Bit Number	Bit Mnemonic	Description
7-4	INT_WK_EVT[3:0]	Interrupt Wakeup Flag Bit 7 = 1: MCU is woken up by INT3 interrupt Bit 6 = reserved Bit 5 = 1: MCU is woken up by INT1 interrupt Bit 4 = 1: MCU is woken up by INT0 interrupt
3	ADC_TOG	ADC Trigger (Wakeup) Flag 1: a Trigger (Wakeup) occurred in ADC 0: a Trigger (Wakeup) not occurred in ADC
2	Reserved	-
1	WTMR_EVT	Watch Timer Trigger (Wakeup) Flag 1: a Trigger (Wakeup) occurred in Watch Timer 0: a Trigger (Wakeup) not occurred in Watch Timer
0	Reserved	-

-: unimplemented.

Wakeup Clear Register CLR_IN_TOG (XFR: 0x6A)

Reset Value: 00h

Bit	Bit 7	Bit 6	Bit 5	Bit 4	Bit 3	Bit 2	Bit 1	Bit 0
Status	W	-	-	-	-	-	-	R
Name	CLR_IN_TOG	Reserved						IN_TOG

Bit Number	Bit Mnemonic	Description
7	CLR_IN_TOG	1: Clear all Input Toggle
6-1	Reserved	-
0	IN_TOG	1: All toggle events logic- or operation if any toggle source occurred, this bit will be set.

-: unimplemented.

The setting of entering Sleep Mode and Wakeup procedure:

1. Set RST_NDF = 1
2. Enable Watchdog Timer (DIS_WDT[7:5] = 101)
3. Select Wakeup sources:

		Idle 1	Idle 2	Sleep Mode
SOURCE		MCU_CLK_OFF	SYSTEM_CLK_OFF	SOURCE_CLK_OFF IRC12M_CLK_OFF
NRST		●	●	●
GPIOx_WK[x]		●	●	●
INT0/1_WK	IE0/1_ADC			
	IE0/1_WTMR			
	IE0/1_ETIMER	●		
	IE0/1_IN_TOG	●	●	●
INT3_WK	IRQ[7:0]	●		
ADC_WK		●	●	●
WTMR_WK		●	●	●

4. Clear all input Trigger Wakeup (CLR_IN_TOF = 1)
5. SOURCE clock select internal 12 MHz RC oscillator (SOURCE_CLK_SLT[1:0] = 00)
6. Entering Sleep Mode (SOURCE_CLK_OFF = 1)
7. Wait for Wakeup Trigger
 - SOURCE clock = IRC 12M, needs to wait for 132 clock cycles to return to the main program
 - SOURCE clock = Crystal, needs to wait for 16 x 1024 clock cycles to return to the main program

6.8 12 MHz RC Oscillator Calibration

WT56F108 has a built-in 12 MHz RC oscillator to reduce the cost of external crystal oscillator. For more precise system clock, external crystal oscillator 12 MHz is available. In addition, it is a better choice to use 32.768 kHz (crystal oscillator) to calibrate internal RC 12 MHz oscillators. (Calibration can reach $\pm 2\%$ at $-40^{\circ}\text{C} \sim +105^{\circ}\text{C}$)

Internal Oscillator Adjust Register RC_LADJ (XFR: 0x70)

Reset Value: 40h

Bit	Bit 7	Bit 6	Bit 5	Bit 4	Bit 3	Bit 2	Bit 1	Bit 0
Status	-	R/W	R/W	R/W	R/W	R/W	R/W	R/W
Name	Reserved	RC_LADJ[6:0]						

Bit Number	Bit Mnemonic	Description
7	Reserved	-
6-0	RC_LADJ[6:0]	Each level 0.5% fine adjustment of the Internal RC oscillator frequency (default value '40H'), 127 levels in total

:- unimplemented.

Note: Internal Oscillator Adjustment Register RC_LADJ[6:0] is allowed to adjust the control circuit of IRC 12 MHz directly.

Internal Oscillator Counter Data High Bytes Register RC12M_CNT[9:2] (XFR: 0x71)

Reset Value: 00h

Bit	Bit 7	Bit 6	Bit 5	Bit 4	Bit 3	Bit 2	Bit 1	Bit 0
Status	R	R	R	R	R	R	R	R
Name	RC12M_CNT[9:2]							

Bit Number	Bit Mnemonic	Description
7-0	RC12M_CNT[9:2]	The counting value RC12M_CNT[9:2] of internal 12 MHz RC oscillator, is paired with RC12M_CNT[1:0] to form a 10-bit counting value

Internal Oscillator Counter Data Low Bytes Register RC12M_CNT[1:0] (XFR: 0x72)

Reset Value: 00h

Bit	Bit 7	Bit 6	Bit 5	Bit 4	Bit 3	Bit 2	Bit 1	Bit 0
Status	-	-	-	-	-	-	R	R
Name	Reserved						RC12M_CNT[1:0]	

Bit Number	Bit Mnemonic	Description
7-2	Reserved	-
1-0	RC12M_CNT[1:0]	The counting value RC12M_CNT[1:0] of internal 12 MHz RC oscillator, is paired with RC12M_CNT[9:2] to form a 10-bit counting value

:- unimplemented.

Internal Oscillator Calibration Control Register RC_CALIB_EN (XFR: 0x73)
Reset Value: 00h

Bit	Bit 7	Bit 6	Bit 5	Bit 4	Bit 3	Bit 2	Bit 1	Bit 0
Status	R/W	-	R/W	-	-	-	-	-
Name	RC_CALIB_EN	Reserved	AUTO_CAL_EN	Reserved				

Bit Number	Bit Mnemonic	Description
7	RC_CALIB_EN	1: Enable RC Oscillator Calibration function
6	Reserved	-
5	AUTO_CAL_EN	1: Enable H/W automatic calibration function
4-0	Reserved	-

-: unimplemented.

Note:

Manual calibration: enable RC_CALIB_EN, and is working together with Firmware.

Automatic calibration: enable RC_CALIB_EN and AUTO_CAL_EN.

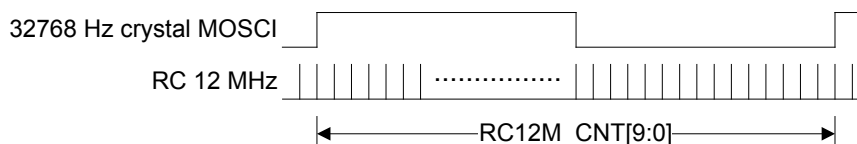
Calibration Theory:

When the external 32.768 kHz oscillator is used, it is available to count in the fixed width of precise 32.768 kHz by internal RC 12 MHz. Then with the counting value we got, we can make a compensation by controlling the Internal Oscillator Adjust Registers RC_LADJ[6:0], reaching $\pm 1\%$ at room temperature.

The range of adjustment:

The actual internal RC frequency \pm (internal RC frequency * 0.005); RC_LADJ[6:0] ranges from 0 ~ 127.

RC12M_CNT[9:0]	External 32.768 kHz Sampled (Hz)	Target Value (Hz)	Tolerance %
360	11796480	12000000	+1.70
361	11829248	12000000	+1.42
362	11862016	12000000	+1.15
363	11894784	12000000	+0.88
364	11927552	12000000	+0.60
365	11960320	12000000	+0.33
366	11993088	12000000	+0.06
367	12025856	12000000	-0.22
368	12058624	12000000	-0.49
369	12091392	12000000	-0.76
370	12124160	12000000	-1.03

Notes:

1. When WT56F108 is waken up from Sleep mode (RC bias is turned on), RC oscillator calibration function needs to wait for at least 83.3ns (at 12 MHz) to return to normal mode.
2. As soon as the RC oscillator calibration function is enabled, read RC12M_CNT[9:2] & RC12M_CNT[1:0] registers twice, then confirm the data is the same to proceed with the calibration process.
3. If RC12M_CNT[9:0] Internal Oscillator Counter Data Register is 511 (0x1FF), indicating that no external oscillator or without enabling external oscillator.
4. When reset, WT56F108 will auto-reload the calibration value of RC 12 MHz into Internal Oscillator Adjustment Register (XFR: 0x70).
5. When enable AUTO_CAL_EN & the external 32.768 kHz oscillator of MCU is also oscillated, MCU will auto calibrate once every 30.5us.
(condition: CRY_12M_PD, IRC_12M_PD1 & IRC_12M_PD2 cannot be turned off).

6.9 Watchdog Timer and Watch Timer

6.9.1 Watchdog Timer (WDT)

Watchdog Timer can be used to detect CPU failures, such as the software deadlock circles caused by noises, voltage disturbance, or power off etc. When an internal counter of the Watchdog Timer overflows, a reset signal will be generated then reset the CPU.

Watchdog Timer is not similar to the general-purpose 8052 Timer 0/1. To prevent a reset occurred on Watchdog Timer, which can be cleared by software before important path of program. When unpredictable reset occurred, user should check the WDT_RST_FLG bit in Reset Flag Register to judge if the previous reset is occurred by Watchdog Timer.

- Clock sources of Watchdog Timer: Internal 32 kHz, or External 32.768 kHz Crystal Oscillator
- Reset Time: 16 ms, 32 ms, 1.024 S or 2.048 S

Watchdog Timer Control Register WDT_CTL (XFR: 0x78)

Reset Value: 02h

Bit	Bit 7	Bit 6	Bit 5	Bit 4	Bit 3	Bit 2	Bit 1	Bit 0
Status	R/W	R/W	R/W	-	-	-	R/W	R/W
Name	DIS_WDT[2:0]			Reserved			WDT_TM_SLT[1:0]	

Bit Number	Bit Mnemonic	Description
7-5	DIS_WDT[2:0]	Watchdog Timer switch 101: Disable Watchdog Timer at the same time clear counts Other value: Enable Watchdog Timer, and also based on the setting of WDT_TM_SLT[1:0] to reset Watchdog Timer Counter
4-2	Reserved	-
1-0	WDT_TM_SLT[1:0]	Watchdog Reset Time setting When the Watchdog uses internal RC 32 kHz oscillator: 00: 16 ms 01: 32 ms 10: 1.024 S 11: 2.048 S When the Watchdog uses external 32.768 kHz Crystal Oscillator: 00: 15.625 ms 01: 31.25 ms 10: 1 S 11: 2 S

-: unimplemented.

Notes:

1. The frequency tolerance of internal 32 kHz RC oscillator is about $\pm 30\%$.
2. The Watchdog Timer clock sources can be selected by the bit WDT_CLK_SLT of System Control Register (XFR: 0x01), with details as below.

System Control Register SYS_CTL (XFR: 0x01)
Reset Value: 80h

Bit	Bit 7	Bit 6	Bit 5	Bit 4	Bit 3	Bit 2	Bit 1	Bit 0
Status	R/W	R/W	R/W	-	-	-	R/W	R/W
Name	RST_NDF	LVR_PD	EN_PC_OVL_RST	Reserved			WDT_CLK_SLT	WTMR_CLK_SLT

Bit Number	Bit Mnemonic	Description
7	RST_NDF	1: NRST pin without digital filter function in 0: NRST pin with digital filter function (4 clocks)
6	LVR_PD	1: turn off low voltage reset power 0: turn on low voltage reset power
5	EN_PC_OVL_RST	1: enable program counter overflow reset 0: disable program counter overflow reset
4-2	Reserved	-
1	WDT_CLK_SLT	1: Watchdog Timer uses external 12 MHz ~ 32.768 kHz crystal oscillator 0: Watchdog Timer uses internal 32 kHz RC oscillator
0	WTMR_CLK_SLT	1: Watch Timer uses external 12 MHz ~ 32.768 kHz crystal oscillator 0: Watch Timer uses internal 32 kHz RC oscillator

-: unimplemented.

Note: If WDT_CLK_SLT = 1 or WTMR_CLK_SLT = 1, must enable EN_CRY_DIV simultaneously and set CRY_DIV[9:0] to allow Watchdog Timer use precise clock source 32 kHz.

External Clock Source Prescaler Control Register 1 CRY_DIV[9:8] (XFR: 0x09)
Reset Value: 01h

Bit	Bit 7	Bit 6	Bit 5	Bit 4	Bit 3	Bit 2	Bit 1	Bit 0
Status	R/W	-	-	-	-	-	R/W	R/W
Name	EN_CRY_DIV	Reserved					CRY_DIV[9:8]	

Bit Number	Bit Mnemonic	Description
7	EN_CRY_DIV	1: enable clock source prescaler of external crystal oscillator 0: disable clock source prescaler of external crystal oscillator
6-2	Reserved	-
1-0	CRY_DIV[9:8]	The prescaler data [9:8] of external Crystal oscillator clock source, is paired with CRY_DIV[7:0] to form a 10-bit prescaler data

-: unimplemented.

External Clock Source Prescaler Control Register 2 CRY_DIV[7:0] (XFR: 0x0A)
Reset Value: 76h

Bit	Bit 7	Bit 6	Bit 5	Bit 4	Bit 3	Bit 2	Bit 1	Bit 0
Status	R/W	R/W	R/W	R/W	R/W	R/W	R/W	R/W
Name	CRY_DIV[7:0]							

Bit Number	Bit Mnemonic	Description
7-0	CRY_DIV[7:0]	The prescaler data [7:0] of external Crystal oscillator clock source, is paired with CRY_DIV[9:8] to form a 10-bit prescaler data

Example:

If external is 12 MHz Crystal Oscillator, and Watchdog Timer & Watch Timer use clock source of low frequency tolerance, must enable External Clock Source Prescaler Control Register and prescaler data.

1. Set prescaler data $CRY_DIV[9:0] = 374$, $12\text{ MHz} / (CRY_DIV[9:0] + 1) = 12\text{ MHz} / 375 = 32\text{ kHz}$
2. Enable clock source prescaler $EN_CRY_DIV = 1$ of external crystal oscillator clock source.

6.9.2 Watch Timer

The application functions of Watch Timer include Timer Interrupt, Timer Wakeup, LCD display frequency and so on.

- The clock source of Watch Timer is 32 kHz internal RC oscillator or 32.768 kHz external oscillator. By this clock, it can generate eight Time bases
- Watch Timer can also be served as the display frequency sources of LCD Driver, with five frequencies to select. (Refer to LCD Driver section)

Watch Timer Control Register WTMR_CTL (XFR: 0x7C)

Reset Value: 80h

Bit	Bit 7	Bit 6	Bit 5	Bit 4	Bit 3	Bit 2	Bit 1	Bit 0
Status	R/W	R	W	-	-	-	-	-
Name	DIS_WTMR	WTMR_EVT	CLR_WTMR_EVT	Reserved				

Bit Number	Bit Mnemonic	Description
7	DIS_WTMR	1: disable Watch Timer 0: enable Watch Timer
6	WTMR_EVT	1: indicates Watch Timer Event (the setting time of Watch Timer as the count reaches WTMR_SLT[2:0]) 0: cleared by CLR_WTMR_EVT = 1
5	CLR_WTMR_EVT	1: Clear Watch Timer event, and then WTMR_EVT = 0
4-0	Reserved	-

-: unimplemented.

Watch Timer Output Selection Register WTMR_SLT[2:0] (XFR: 0x7D)

Reset Value: 00h

Bit	Bit 7	Bit 6	Bit 5	Bit 4	Bit 3	Bit 2	Bit 1	Bit 0
Status	-	-	-	-	-	R/W	R/W	R/W
Name	Reserved					WTMR_SLT[2:0]		

Bit Number	Bit Mnemonic	Description
7-3	Reserved	-
2-0	WTMR_SLT[2:0]	Watch Timer Time base selection bit (If needs to be precise, using external Crystal Oscillator 32.768 kHz) is recommended. 000: watch time = 3.91 ms 001: watch time = 31.25 ms 010: watch time = 62.50 ms 011: watch time = 125 ms 100: watch time = 0.25 S 101: watch time = 0.5 S 110: watch time = 1 S 111: watch time = 2 S

-: unimplemented.

6.10 LCD Driver

WT56F108 contains LCD driver and control Circuit to drive LCD panel directly. Internal RC 32 kHz or external 32.768 kHz oscillator is available for LCD system clock source selection.

WT56F108 supports LCD driver with below features:

- Built-in LCD Bias Voltages circuit with three selectable bias: 1/2 or 1/3 Bias
- Internal Register supports Duty Cycles adjustment: 1/2, 1/3, or 1/4 Duty
- Duty cycle/Bias/Frequency can be set by software
- When enabling LCD function, configure the Segment and the COM corresponding GPIO as Input.
- **The display frequency source of LCD Driver is Watch Timer, please refer to 6.9.2 Watch Timer**

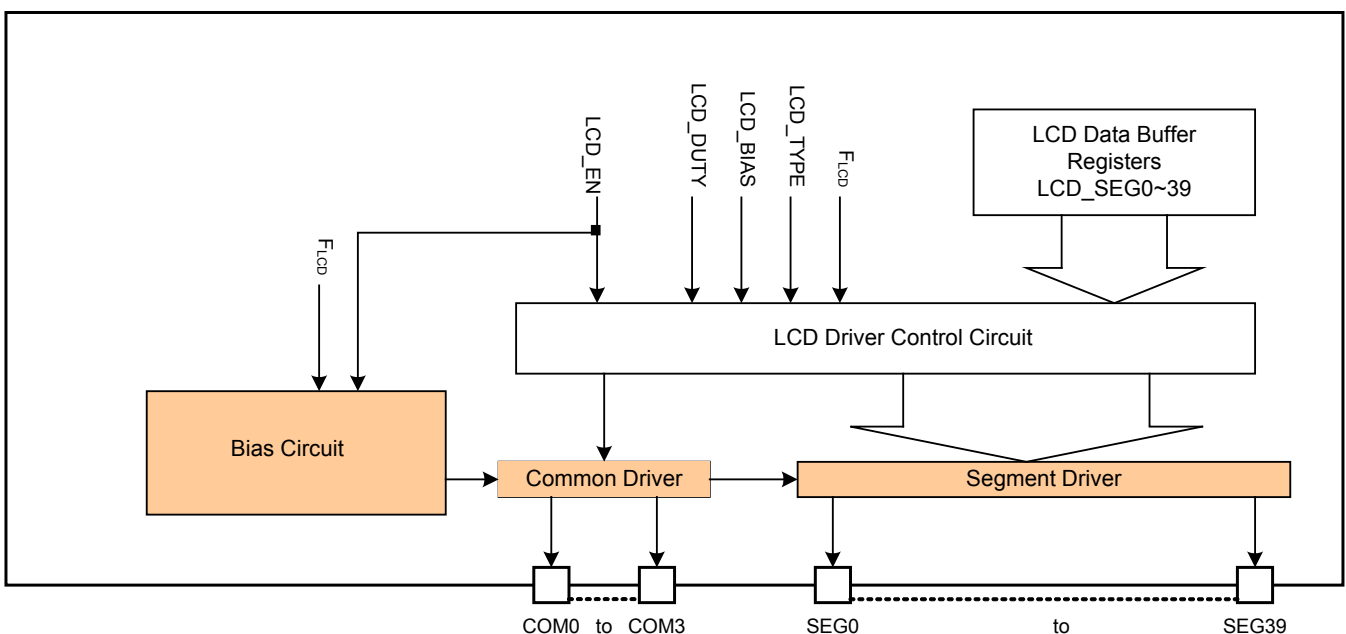

LCD Driver Control Register 1 LCD_CTL1 (XFR: 0xA8)

Reset Value: 00h

Bit	Bit 7	Bit 6	Bit 5	Bit 4	Bit 3	Bit 2	Bit 1	Bit 0
Status	R/W	R/W	-	-	-	-	-	-
Name	LCD_EN	LCD_TYPE	Reserved					

Bit Number	Bit Mnemonic	Description
7	LCD_EN	LCD Power Control (During setting the related register of the LCD Driver, turning off the LCD power is essential.) 1: turn on LCD Driver power 0: turn off LCD Driver power
6	LCD_TYPE	LCD Driving waveform selection 1: B type driving waveform 0: A type driving waveform
5-0	Reserved	-

-: unimplemented.

LCD Driver Control Register 2 LCD_CTL2 (XFR: 0xA9)
Reset Value: 00h

Bit	Bit 7	Bit 6	Bit 5	Bit 4	Bit 3	Bit 2	Bit 1	Bit 0
Status	R/W	R/W	R/W	R/W	R/W	R/W	-	-
Name	LCD_CLK[2:0]			LCD_BIAS	LCD_DUTY[1:0]		Reserved	

Bit Number	Bit Mnemonic	Description
7-5	LCD_CLK[2:0]	LCD Scanned Frequency setting. If external 32.768 kHz oscillator is selected as LCD system clock source, scanned frequency is 2048 Hz when set LCD_CLK[2:0] = 000 (please refer to "LCD Driver Frame frequency setting table" for more details). 000 = $fs/2^4$ (if $fs = 32.768$ kHz, $lcd_clk = 2048$ Hz) 001 = $fs/2^5$ 010 = $fs/2^6$ 011 = $fs/2^7$ 1xx = $fs/2^8$
4	LCD_BIAS	LCD bias selection 1: 1/3 0: 1/2
3-2	LCD_DUTY[1:0]	LCD duty selection 00: static (1/2 duty and bias = VLCD) 01: 1/3 duty 1x: 1/4 duty
1-0	Reserved	-

-: unimplemented.
LCD Driver Segment Output Enable Register 1 LCD_SEG_EN[7:0] (XFR: 0xAB)
Reset Value: 00h

Bit	Bit 7	Bit 6	Bit 5	Bit 4	Bit 3	Bit 2	Bit 1	Bit 0
Status	R/W	R/W	R/W	R/W	R/W	R/W	R/W	R/W
Name	LCD_SEG_EN[7:0]							

Bit Number	Bit Mnemonic	Description
7-0	LCD_SEG_EN[7:0]	SEGDx output enable setting; 1: SEG Dx output 0000_0001: enable SEG D0 data output 0000_0011: enable SEG D1~0 data output 0111_1111: enable SEG D6~0 data output 1111_1111: enable SEG D7~0 data output

LCD Driver Segment Output Enable Register 2 LCD_SEG_EN[15:8] (XFR: 0xAC)
Reset Value: 00h

Bit	Bit 7	Bit 6	Bit 5	Bit 4	Bit 3	Bit 2	Bit 1	Bit 0
Status	R/W	R/W	R/W	R/W	R/W	R/W	R/W	R/W
Name	LCD_SEG_EN[15:8]							

Bit Number	Bit Mnemonic	Description
7-0	LCD_SEG_EN[15:8]	SEGDx output enable setting; 1: SEG Dx output 0000_0001: enable SEG D8 data output

Bit Number	Bit Mnemonic	Description
		0000_0011: enable SEG9~8 data output 0111_1111: enable SEG14~8 data output 1111_1111: enable SEG15~8 data output

LCD Driver Segment Enable Register 3 LCD_SEG_EN[23:16] (XFR: 0xAD)
Reset Value: 00h

Bit	Bit 7	Bit 6	Bit 5	Bit 4	Bit 3	Bit 2	Bit 1	Bit 0
Status	R/W	R/W	R/W	R/W	R/W	R/W	R/W	R/W
Name	LCD_SEG_EN[23:16]							

Bit Number	Bit Mnemonic	Description
7-0	LCD_SEG_EN[23:16]	SEGDx output enable setting; 1: SEG Dx output 0000_0001: enable SEG16 data output 0000_0011: enable SEG17~16 data output 0111_1111: enable SEG22~16 data output 1111_1111: enable SEG23~16 data output

LCD Driver Segment Enable Register 4 LCD_SEG_EN[31:24] (XFR: 0xAE)
Reset Value: 00h

Bit	Bit 7	Bit 6	Bit 5	Bit 4	Bit 3	Bit 2	Bit 1	Bit 0
Status	R/W	R/W	R/W	R/W	R/W	R/W	R/W	R/W
Name	LCD_SEG_EN[31:24]							

Bit Number	Bit Mnemonic	Description
7-0	LCD_SEG_EN[31:24]	SEGDx output enable setting; 1: SEG Dx output 0000_0001: enable SEG24 data output 0000_0011: enable SEG25~24 data output 0111_1111: enable SEG30~24 data output 1111_1111: enable SEG31~24 data output

LCD Driver Segment Enable Register 5 LCD_SEG_EN[39:32] (XFR: 0xAF)
Reset Value: 00h

Bit	Bit 7	Bit 6	Bit 5	Bit 4	Bit 3	Bit 2	Bit 1	Bit 0
Status	R/W	R/W	R/W	R/W	R/W	R/W	R/W	R/W
Name	LCD_SEG_EN[39:32]							

Bit Number	Bit Mnemonic	Description
7-0	LCD_SEG_EN[39:32]	SEGDx output enable setting; 1: SEG Dx output 0001: enable SEG32 data output 0011: enable SEG33~32 data output 0111: enable SEG38~32 data output 1111: enable SEG39~32 data output

Note: If the GPIO multiplexed with SEG did not use SEG, which allows LCD SEG mapping output pins as Tri-state by this Enable Register LCD_SEG_EN[39:0]

LCD Driver Display Data Register 0~39 LCD_SEG Dx[7:0] (XFR: 0x80 ~ 0xA7)
Reset Value: 00h

The table below is LCD display data Register mapping table:

4 COM LCD (COM0~3, SEG0~39)

Address	Register Name	7	6	5	4	3	2	1	0
						COM3	COM2	COM1	COM0
\$80H	LCD_SEG D0[3:0]					SEG0	SEG0	SEG0	SEG0
\$81H	LCD_SEG D1[3:0]					SEG1	SEG1	SEG1	SEG1
\$82H	LCD_SEG D2[3:0]					SEG2	SEG2	SEG2	SEG2
\$83H	LCD_SEG D3[3:0]					SEG3	SEG3	SEG3	SEG3
\$84H	LCD_SEG D4[3:0]					SEG4	SEG4	SEG4	SEG4
\$85H	LCD_SEG D5[3:0]					SEG5	SEG5	SEG5	SEG5
\$86H	LCD_SEG D6[3:0]					SEG6	SEG6	SEG6	SEG6
\$87H	LCD_SEG D7[3:0]					SEG7	SEG7	SEG7	SEG7
\$88H	LCD_SEG D8[3:0]					SEG8	SEG8	SEG8	SEG8
\$89H	LCD_SEG D9[3:0]					SEG9	SEG9	SEG9	SEG9
\$8AH	LCD_SEG D10[3:0]					SEG10	SEG10	SEG10	SEG10
\$8BH	LCD_SEG D11[3:0]					SEG11	SEG11	SEG11	SEG11
\$8CH	LCD_SEG D12[3:0]					SEG12	SEG12	SEG12	SEG12
\$8DH	LCD_SEG D13[3:0]					SEG13	SEG13	SEG13	SEG13
\$8EH	LCD_SEG D14[3:0]					SEG14	SEG14	SEG14	SEG14
\$8FH	LCD_SEG D15[3:0]					SEG15	SEG15	SEG15	SEG15
\$90H	LCD_SEG D16[3:0]					SEG16	SEG16	SEG16	SEG16
\$91H	LCD_SEG D17[3:0]					SEG17	SEG17	SEG17	SEG17
\$92H	LCD_SEG D18[3:0]					SEG18	SEG18	SEG18	SEG18
\$93H	LCD_SEG D19[3:0]					SEG19	SEG19	SEG19	SEG19
\$94H	LCD_SEG D20[3:0]					SEG20	SEG20	SEG20	SEG20
\$95H	LCD_SEG D21[3:0]					SEG21	SEG21	SEG21	SEG21
\$96H	LCD_SEG D22[3:0]					SEG22	SEG22	SEG22	SEG22
\$97H	LCD_SEG D23[3:0]					SEG23	SEG23	SEG23	SEG23
\$98H	LCD_SEG D24[3:0]					SEG24	SEG24	SEG24	SEG24
\$99H	LCD_SEG D25[3:0]					SEG25	SEG25	SEG25	SEG25
\$9AH	LCD_SEG D26[3:0]					SEG26	SEG26	SEG26	SEG26
\$9BH	LCD_SEG D27[3:0]					SEG27	SEG27	SEG27	SEG27
\$9CH	LCD_SEG D28[3:0]					SEG28	SEG28	SEG28	SEG28
\$9DH	LCD_SEG D29[3:0]					SEG29	SEG29	SEG29	SEG29
\$9EH	LCD_SEG D30[3:0]					SEG30	SEG30	SEG30	SEG30
\$9FH	LCD_SEG D31[3:0]					SEG31	SEG31	SEG31	SEG31
\$A0H	LCD_SEG D32[3:0]					SEG32	SEG32	SEG32	SEG32
\$A1H	LCD_SEG D33[3:0]					SEG33	SEG33	SEG33	SEG33
\$A2H	LCD_SEG D34[3:0]					SEG34	SEG34	SEG34	SEG34
\$A3H	LCD_SEG D35[3:0]					SEG35	SEG35	SEG35	SEG35
\$A4H	LCD_SEG D36[3:0]					SEG36	SEG36	SEG36	SEG36
\$A5H	LCD_SEG D37[3:0]					SEG37	SEG37	SEG37	SEG37
\$A6H	LCD_SEG D38[3:0]					SEG38	SEG38	SEG38	SEG38
\$A7H	LCD_SEG D39[3:0]					SEG39	SEG39	SEG39	SEG39

LCD Driver Bias table:

LCD Power Supply	1/2	1/3
$V_{LCD} = VDD$	V_{LCD}	V_{LCD}
VLCD2	-	$2/3 V_{LCD}$
VLCD3	$1/2 V_{LCD}$	$1/3 V_{LCD}$
VSS	VSS	VSS

LCD Driver Frame frequency setting table:

LCD_Frame (LCD_CLK[2:0])	LCD_CLK (Hz)	Frame Frequency (Hz)		
	Clock	Static (1/2 Duty)	1/3 Duty	1/4 Duty
000	2048	1024	683	512
001	1024	512	341	256
010	512	256	171	128
011	256	128	85	64
1xx	128	64	43	32

Boost circuits connection for LCD voltage

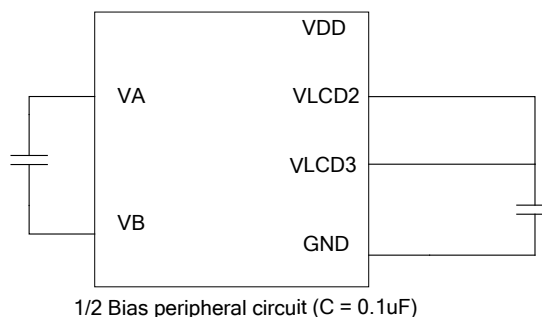
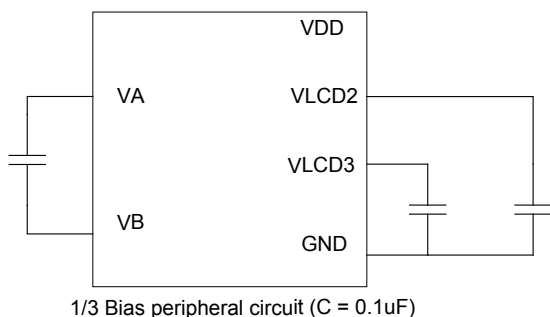

1/2 Duty, 1/2 Bias LCD driving waveform

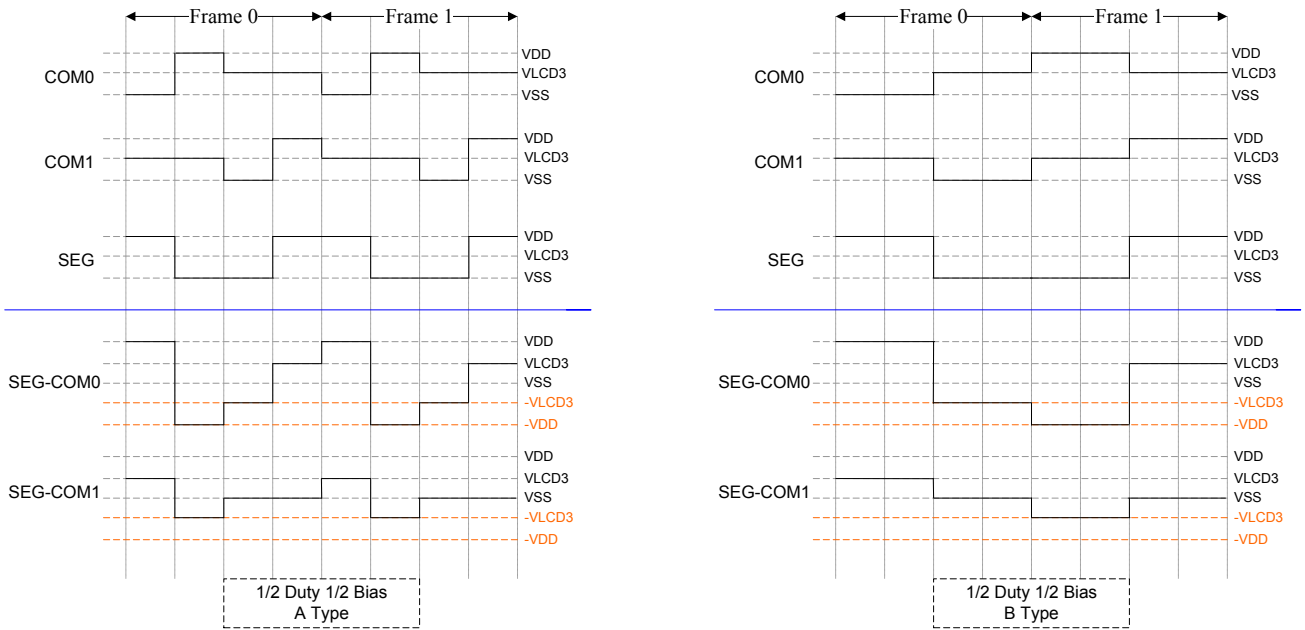

1/3 Duty, 1/3 Bias LCD driving waveform

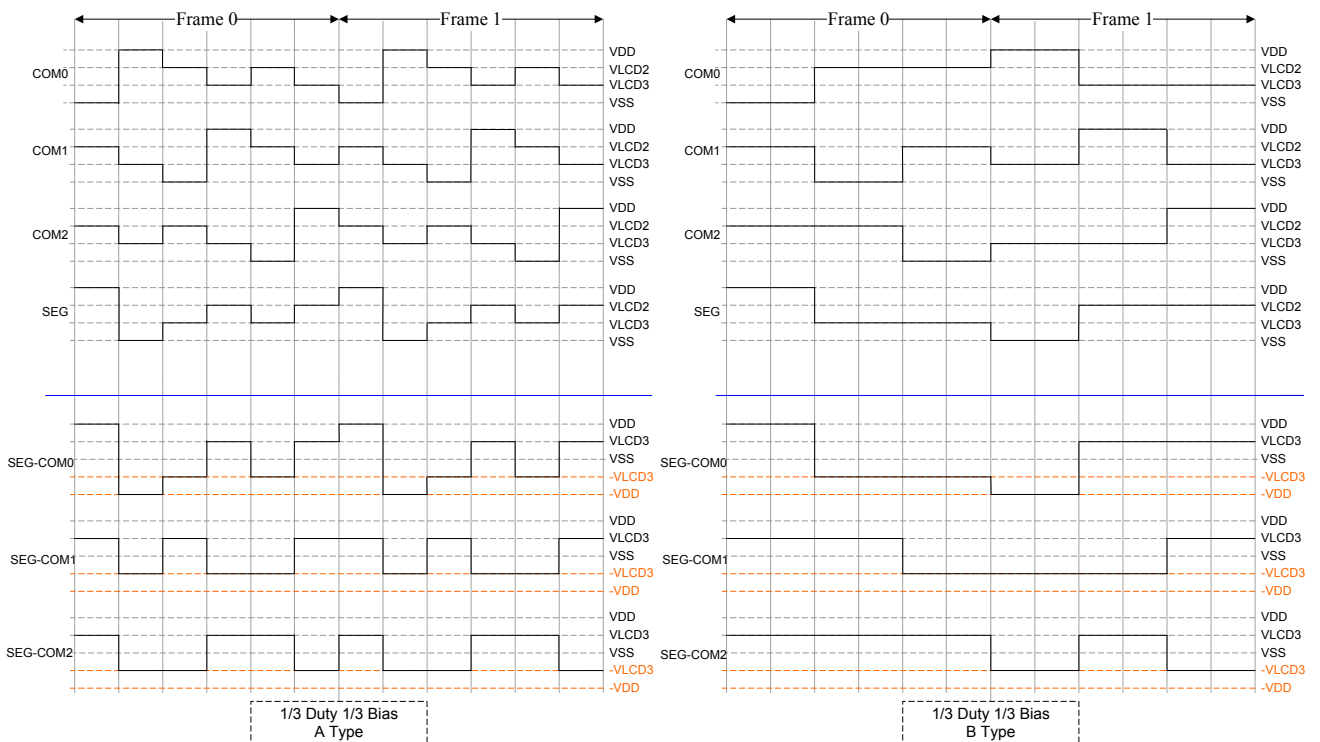

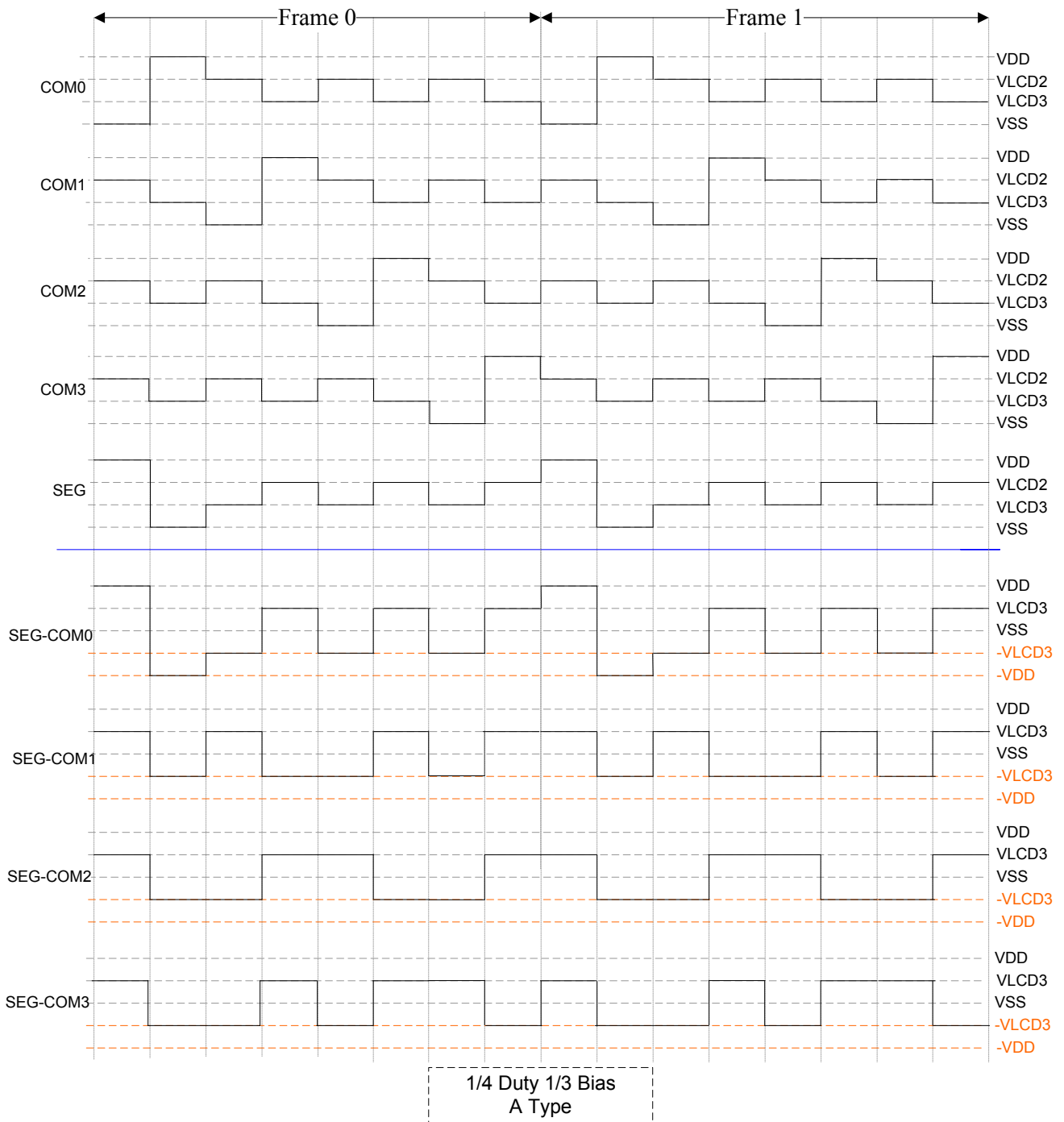

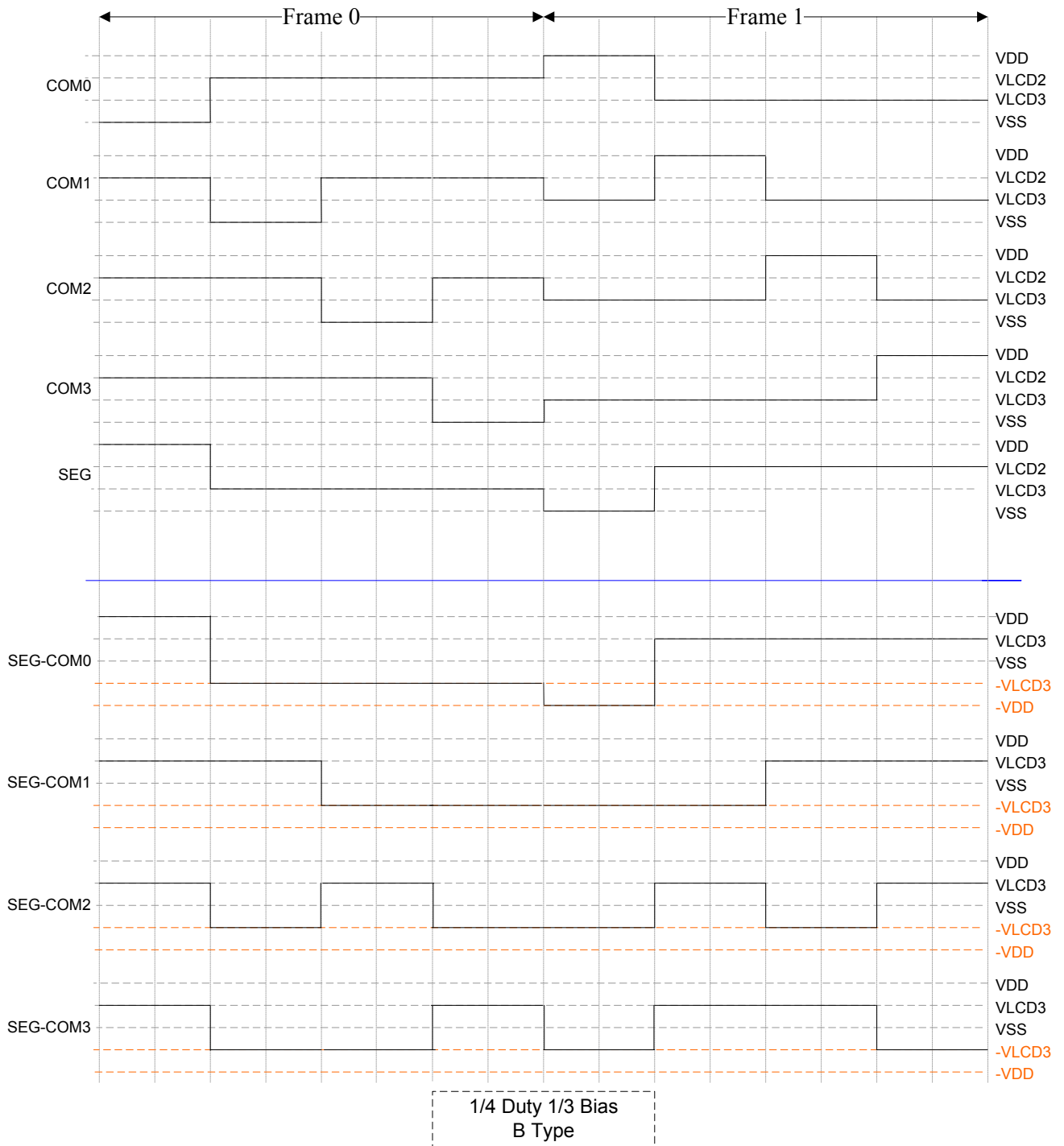

6.11 Enhanced Timer/Counter

The clock sources of enhanced Timer/Counter are from internal or external clock, and it is determined by register.

The Enhanced Timer/Counter has two operation modes: 1. Compare mode. 2. Capture mode. Furthermore there are three types of Capture Match condition for selection: High-level, Low-level, and Period of Capture mode.

1. Compare mode:

The Enhanced Timer/Counter contains one 16-bit Counter and one 16-bit enhanced Buffer (ETM_BUF[15:0]). When enable the Enhanced Timer/Counter (EN_ETM = 1) and set as the compare mode (ETM_MODE[1:0] = 00), the counter will start counts according to the clock sources, and an interrupt will occur once the data of the counter matches the data of the enhanced Buffer. Each match will output the trigger of ETMO (general-purpose I/O port A0) and clear the counter value of the internal 16-bit Counter. Please refer to the figure below.

Compare mode operation flow:

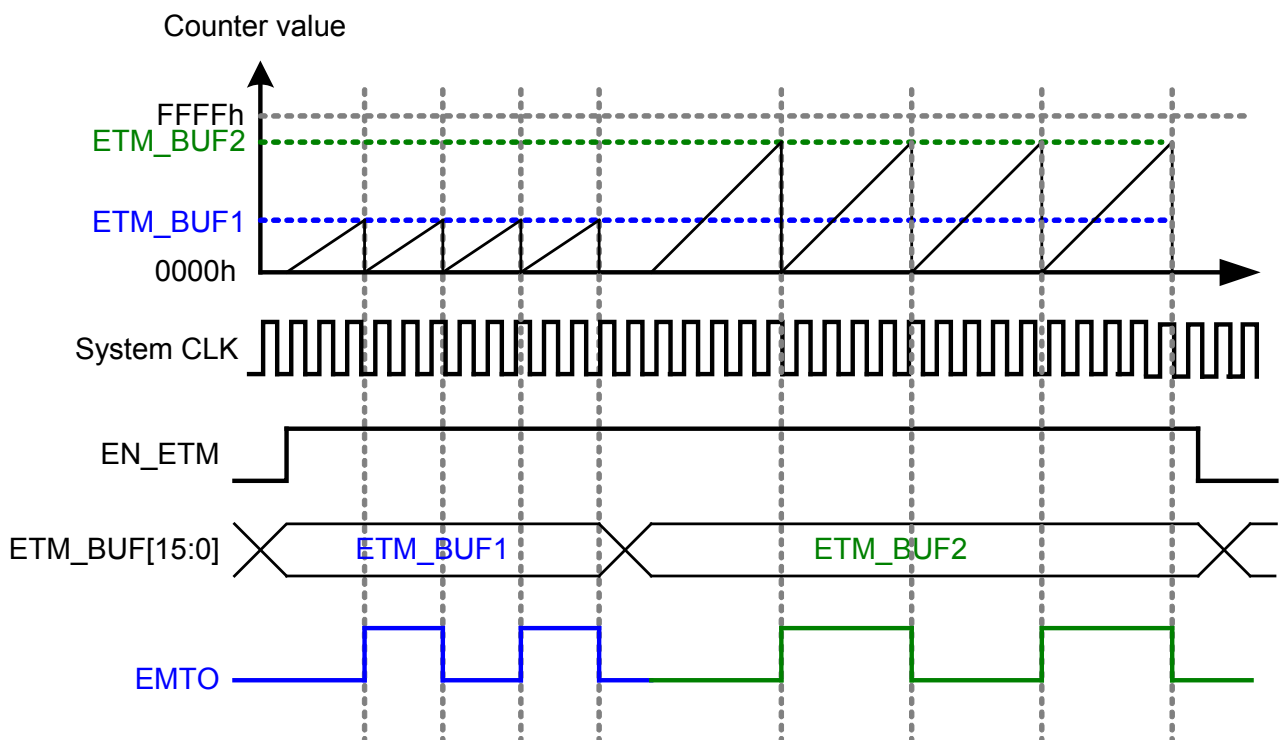

2. Capture mode

If the Enhanced Timer/Counter is set as the Capture mode (ETM_MODE[1:0] = 01, 10, 11), and it is enabled (EN_ETM = 1), the capture operation starts. When the input status changes then match with the setting capture condition, the internal 16-bit counter will be cleared and restarts counting, then reload the counter value into 16-bit Buffer (ETM_BUF[15:0]) automatically. At the same time, the software can read the counter value from the Enhanced Timer/Counter Data Buffer Register (register B3H & B4H), and a capture interrupt, capture flag and output ETMO may be generated. Please refer to the figure below.

Capture mode operation flow:

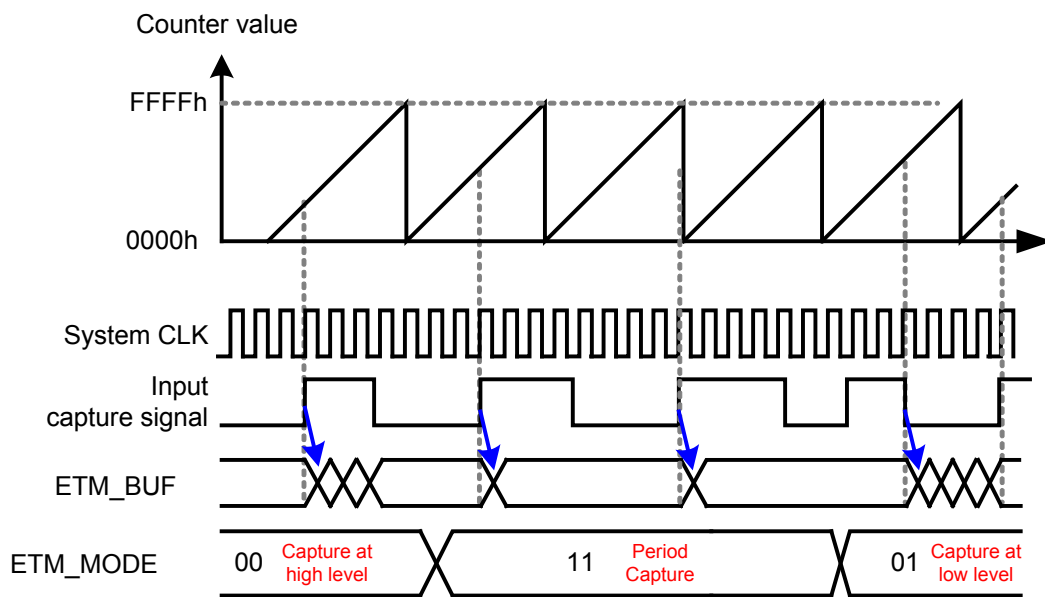

Enhanced Timer/Counter Control Register 1 ETM_CTL1(XFR: 0xB0)

Reset Value: 00h

Bit	Bit 7	Bit 6	Bit 5	Bit 4	Bit 3	Bit 2	Bit 1	Bit 0
Status	R/W	R/W	R/W	R/W	RW	R/W	R/W	R/W
Name	EN_ETM	ETM_MODE[1:0]		ETM_SOURCE[2:0]			ETM_CLK_PSCAL[1:0]	

Bit Number	Bit Mnemonic	Description
7	EN_ETM	1: Enable Enhanced Timer/Counter
6-5	ETM_MODE[1:0]	00: Compare mode (SOURCE clock = 12 MHz) 01: capture counting mode, capture the interval of high level 10: capture counting mode, capture the interval of low level 11: capture counting mode, capture the interval period (based on the setting ETM_IN_PSCAL[1:0] to capture)
4-2	ETM_SOURCE[2:0]	Compare Mode: Set clock source prescalers of the internal 16-bit Counter 000: Enhanced Timer/Counter clock source = SOURCE clock 001: Enhanced Timer/Counter clock source = SOURCE clock/12 100: Enhanced Timer/Counter input external clock source channel = ETMIA (GPIOA7) 101: Enhanced Timer/Counter input external clock source channel =

Bit Number	Bit Mnemonic	Description
		ETMIB (GPIOA3) 110: Enhanced Timer/Counter input external clock source channel = ETMIC (GPIOA1) Other value: Enhanced Timer/Counter clock source = SOURCE clock Capture mode: Set Enhanced Timer/Counter clock source & capture channel 000: Enhanced Timer/Counter clock source = SOURCE clock , capture channel is ETMIA (GPIOA7) 001: Enhanced Timer/Counter clock source = SOURCE clock , capture channel is ETMIB (GPIOA3) 010: Enhanced Timer/Counter clock source = SOURCE clock , capture channel is ETMIC (GPIOA1) 100: Enhanced Timer/Counter clock source = SOURCE clock / 12 , capture channel is ETMIA (GPIOA7) 101: Enhanced Timer/Counter clock source = SOURCE clock / 12 , capture channel is ETMIB (GPIOA3) 110: Enhanced Timer/Counter clock source = SOURCE clock / 12 , capture channel is ETMIC (GPIOA1)
1-0	ETM_IN_PSCAL [1:0]	Set input channel period prescaler 00: input period/1 01: input period/4 10: input period/8 11: input period/16

Note: As the external clock source of the Enhanced Timer/Counter is one of GPIOA7, GPIOA3, or GPIOA1, please set the complex function of GPIO as GPIO, and input floating.

Enhanced Timer/Counter Interrupt Register ETM_INT (XFR: 0xB2)
Reset Value: 00h

Bit	Bit 7	Bit 6	Bit 5	Bit 4	Bit 3	Bit 2	Bit 1	Bit 0
Status	R/W	R/W	R/W	W	R	R	R	-
Name	EN_CAPINT	EN_OVRINT	EN_CMPINT	CLR_FLAG	CAPF	OVRF	CPMF	Reserved

Bit Number	Bit Mnemonic	Description
7	EN_CAPINT	1: Enable input capture interrupt 0: Disable input capture interrupt
6	EN_OVRINT	1: Enable overflow interrupt 0: Disable overflow interrupt
5	EN_CMPINT	1: Enable Compare Match Interrupt 0: Disable Compare Match Interrupt
4	CLR_FLAG	1: Clear all Enhanced Timer/Counter flags
3	CAPF	Input capture flag
2	OVRF	Overflow flag When an overflow occurred in internal 16-bit counter, OVRF = 1
1	CPMF	Compare match flag When internal 16-bit counter has the same value as ETM_BUF, CPMF = 1
0	Reserved	-

-: unimplemented.

Enhanced Timer/Counter Data Buffer Low Bytes Register ETM_BUF[7:0] (XFR: 0xB3) Reset Value: 00h

Bit	Bit 7	Bit 6	Bit 5	Bit 4	Bit 3	Bit 2	Bit 1	Bit 0
Status	R/W	R/W	R/W	R/W	R/W	R/W	R/W	R/W
Name	ETM_BUF[7:0]							

Bit Number	Bit Mnemonic	Description
7-0	ETM_BUF[7:0]	Paired with ETM_BUF[15:8] to form a 16-bit counter value Read: In Capture mode, the counter value of the captured input signal Write: In Compare mode, as the compare value to compare with the internal 16-bit counter

Enhanced Timer/Counter Data Buffer High Bytes Register ETM_BUF [15:8] (XFR: 0xB4) Reset Value: 80h

Bit	Bit 7	Bit 6	Bit 5	Bit 4	Bit 3	Bit 2	Bit 1	Bit 0
Status	R/W	R/W	R/W	R/W	R/W	R/W	R/W	R/W
Name	ETM_BUF[15:8]							

Bit Number	Bit Mnemonic	Description
7-0	ETM_BUF[15:8]	Paired with ETM_BUF[7:0] to form a 16-bit counter value Read: In Capture mode, the counter value of the captured input signal Write: In Compare mode, as the compare value to compare with the internal 16-bit counter

Note: In Capture mode, ETM_BUF[15:8] and ETM_BUF[7:0] form a 16-bit counter value, and the counter value should be incremented by one to be the actual counter value in application.

Explanation 1:

Due to internal capture source goes through the filter, the pulse width of input signal high level and low level must be greater than the width of four SYSTEM Clocks.

Explanation 2:

ETM_IN_PSCAL[1:0] = 00: Select Capture Input Source 1 cycle, then the Capture effective Resolution is $1 / 12 \text{ MHz} / 1 = 83.333 \text{ ns}$

ETM_IN_PSCAL[1:0] = 11: Select Capture Input Source 16 cycles, then the Capture effective Resolution is $1 / 12 \text{ MHz} / 16 = 5.208 \text{ ns}$

When select Capture 16 cycles allow the enhanced Timer/Counter to get more significant digits, to reduce capture error.

6.12 Analog/Digital Converter (ADC)

WT56F108 has a built-in 12-channel 10-bit Analog/Digital Converter, and it also provides two conversion modes (Single, Voltage Compare) and four conversion rate (2 MHz, 1 MHz, 500 kHz, and 125 kHz) for selection. Reference Voltage Source VREF has two options: Power Voltage VDD, External Reference Voltage VREF.

The conversion time of A/D Converter is 14us (sampled time 4 us + conversion time 10 us) based on the conversion rate of 1 MHz.

Single Mode:

Turn on the A/D converter power (XFR: 0xD0 ADC_CTL, and ADC_PD = 0), and set the ADC_SINGLE_CVT = 1, then the A/D conversion starts. When ADC_SINGLE_CVT = 0, the conversion is finished. When conversion is completed, the conversion data will be updated and an interrupt will generate (ADFINSH_FLG = 1). If ADC convert finish Interrupt is enabled (EN_ADFINSH_INT = 1), the ADC interrupt will generate.

Voltage Compare Mode:

When turn on the A/D converter power (XFR: 0xD0 ADC_CTL, and ADC Control Register ADC_PD = 0), and activate the Compare function (EN_ADC_CMP = 1), the conversion data of Analog input compare 10-bit setting of XFR: 0xD4 & 0xD5 (ADC_CMP_V). When the corresponding digital value of the voltage analog input is greater than (ADC_BIG = 0) or smaller than (ADC_BIG = 1) the setting value of ADC_CMP_V register, the ADC interrupt will occur. The Voltage Compare function of A/D Converter module works as a wakeup source. In addition, working together with XFR: 0xD1 ADC_SEL & ADCMP_TM, it can define ADC turn on time for power-saving purpose.

ADC Control Register ADC_CTL (XFR: 0xD0) Reset Value: 80h

Bit	Bit 7	Bit 6	Bit 5	Bit 4	Bit 3	Bit 2	Bit 1	Bit 0
Status	R/W	R/W	-	-	R/W	R/W	-	R/W
Name	ADC_PD	ADC_SINGLE_CVT	Reserved		EN_ADC_CMP	EN_ADC_FLT	Reserved	ADC_BIG

Bit Number	Bit Mnemonic	Description
7	ADC_PD	Analog/Digital Converter Power Control 1: turn off ADC power 0: turn on ADC power
6	ADC_SINGLE_CVT	ADC start convert bit (single convert mode) 1: ADC start convert 1 => 0: convert finished (hardware will be auto-cleared as "0")
5-4	Reserved	-
3	EN_ADC_CMP	1: Enable ADC compare mode (Voltage compare mode)
2	EN_ADC_FLT	1: Enable ADC filter (need to wait for 332nsec) 0: Disable filter function
1	Reserved	-
0	ADC_BIG	ADC data compare flag 1: the data set when $V_{in} < ADC_CMP_V[9:0]$ 0: the data set when $V_{in} > ADC_CMP_V[9:0]$ V_{in} : the channel select by EN_AD[3:0]

Note: Only one converting mode is allowed to enable the ADC at the same time, otherwise ADC may work abnormally.

ADC Set Control Register ADC_SEL (XFR: 0xD1)
Reset Value: 40h

Bit	Bit 7	Bit 6	Bit 5	Bit 4	Bit 3	Bit 2	Bit 1	Bit 0
Status	R/W	R/W	R/W	-	-	-	-	R/W
Name	ADC_CLK_SEL[1:0]		ADCMP_TM	Reserved				ADC_VREF_SEL

Bit Number	Bit Mnemonic	Description
7-6	ADC_CLK_SEL[1:0]	ADC convert time clock base 00: 2 MHz 01: 1 MHz 10: 500 kHz 11: 125 kHz
5	ADCMP_TM	1: ADC is based on Watch Timer to turn on 32us Voltage compare function at every 32ms for power-saving purpose 0: ADC always compare time
4-1	Reserved	-
0	ADC_VREF_SEL[1:0]	ADC reference voltage selection 1: from VREF pin 0: from VDD

:- unimplemented.

ADC Interrupt Control Register ADC_INT (XFR: 0xD2)
Reset Value: 00h

Bit	Bit 7	Bit 6	Bit 5	Bit 4	Bit 3	Bit 2	Bit 1	Bit 0
Status	R/W	R/W	-	-	R	R	R	-
Name	EN_ADCMP_INT	EN_ADFINSH_INT	Reserved		ADCMP_FLG	ADFINSH_FLG	ADCMP_FLG	Reserved

Bit Number	Bit Mnemonic	Description
7	EN_ADCMP_INT	1: Enable ADC Compare Interrupt 0: Disable ADC Compare Interrupt
6	EN_ADFINSH_INT	1: Enable ADC Convert Finish Interrupt 0: Disable ADC Convert Finish Interrupt
5-4	Reserved	-
3	ADCMP_EDG_FLG	ADC Compare Mode Flag. If the condition selected by ADC_BIG bit in ADC Control Register is met, ADCMP_EDG_FLG = 1.
2	ADFINSH_FLG	ADC Finish Interrupt Flag (If the ADC finished convert in single mode, ADFINSH_FLG = 1)
1	ADCMP_FLG	ADC Data Compare Flag 1: when $V_{in} > ADC_CMP_V[9:0]$ 0: when $V_{in} < ADC_CMP_V[9:0]$ V_{in} : channel selected by EN_AD[3:0]
0	Reserved	-

:- unimplemented.

Note: When read AD_DATA[9:0], the hardware will auto clear the ADCMP_EDG_FLG & ADFINSH_FLG flag.

ADC Channel Control Register ADC_ENCH (XFR: 0xD3) Reset Value: 00h

Bit	Bit 7	Bit 6	Bit 5	Bit 4	Bit 3	Bit 2	Bit 1	Bit 0
Status	-	-	-	-	R/W	R/W	R/W	R/W
Name	Reserved				EN_AD[3:0]			

Bit Number	Bit Mnemonic	Description
7-4	Reserved	-
3-0	EN_AD[3:0]	Analog/Digital Channel Selection 0000: Select Channel CH0 0001: Select Channel CH1 0010: Select Channel CH2 0011: Select Channel CH3 0100: Select Channel CH4 0101: Select Channel CH5 0110: Select Channel CH6 0111: Select Channel CH7 1000: Select Channel CH8 1001: Select Channel CH9 1010: Select Channel CH10 1011: Select Channel CH11 11xx: reserved

-: unimplemented.

ADC Voltage Compare Data High Bytes Register ADC_CMP_V[9:2] (XFR: 0xD4) Reset Value: 80h

Bit	Bit 7	Bit 6	Bit 5	Bit 4	Bit 3	Bit 2	Bit 1	Bit 0
Status	R/W	R/W	R/W	R/W	R/W	R/W	R/W	R/W
Name	ADC_CMP_V[9:2]							

Bit Number	Bit Mnemonic	Description
7-0	ADC_CMP_V[9:2]	ADC_CMP_V[9:2] Compare Voltage Setting, paired with ADC_CMP_V[1:0] to form a 10-bit data

ADC Voltage Compare Data Low Bytes Register ADC_CMP_V[1:0] (XFR: 0xD5) Reset Value: 00h

Bit	Bit 7	Bit 6	Bit 5	Bit 4	Bit 3	Bit 2	Bit 1	Bit 0
Status	-	-	-	-	-	-	R/W	R/W
Name	Reserved						ADC_CMP_V[1:0]	

Bit Number	Bit Mnemonic	Description
7-2	Reserved	-
1-0	ADC_CMP_V[1:0]	ADC_CMP_V[1:0] Compare Voltage setting, paired with ADC_CMP_V[9:2] to form a 10-bit data

-: unimplemented.

ADC Converted Data High Bytes Register AD_DATA[9:2] (XFR: 0xD6) Reset Value: 00h

Bit	Bit 7	Bit 6	Bit 5	Bit 4	Bit 3	Bit 2	Bit 1	Bit 0
Status	R	R	R	R	R	R	R	R
Name	AD_DATA[9:2]							

Bit Number	Bit Mnemonic	Description
7-0	AD_DATA[9:2]	AD_DATA[9:2] converted data setting, paired with AD_DATA[1:0] to form a 10-bit data

ADC Converted Data Low Bytes Register AD_DATA[1:0] (XFR: 0xD7) Reset Value: 00h

Bit	Bit 7	Bit 6	Bit 5	Bit 4	Bit 3	Bit 2	Bit 1	Bit 0
Status	-	-	-	-	-	-	R	R
Name	Reserved						AD_DATA[1:0]	

Bit Number	Bit Mnemonic	Description
7-2	Reserved	-
1-0	AD_DATA[1:0]	AD_DATA[1:0] converted data setting, paired with AD_DATA[9:2] to form a 10-bit data

-: unimplemented.

The setting of Enabling Analog/Digital Converter converted Data procedure:

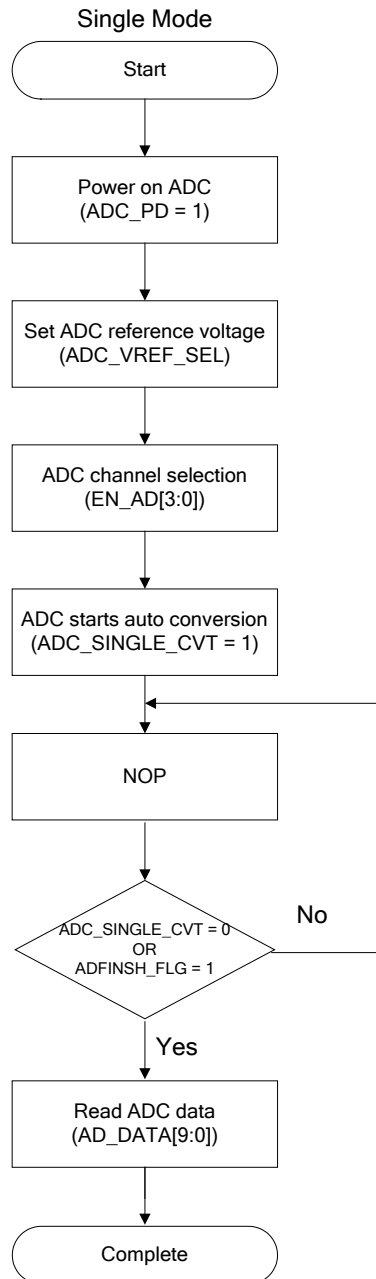

6.13 Low Voltage Detection Reset (LVDR)

WT56F108 has a built-in Low Voltage Detection circuitry which can detect the supply voltage falls below the minimum specified operating voltage then generates a Reset.

- The Enable & Disable function of Low Voltage Detection Reset are controlled by the software
- Low Voltage Detection level provides 2-level of voltage for selection: 2.00V or 2.75V
- If operating frequency > 6 MHz, set LVR on, LVDR = 2.75V to ensure the MCU reset function is normal in low voltage
- If operating frequency \leq 6 MHz, set LVR on, LVDR = 2.0V to ensure the MCU reset function is normal in low voltage

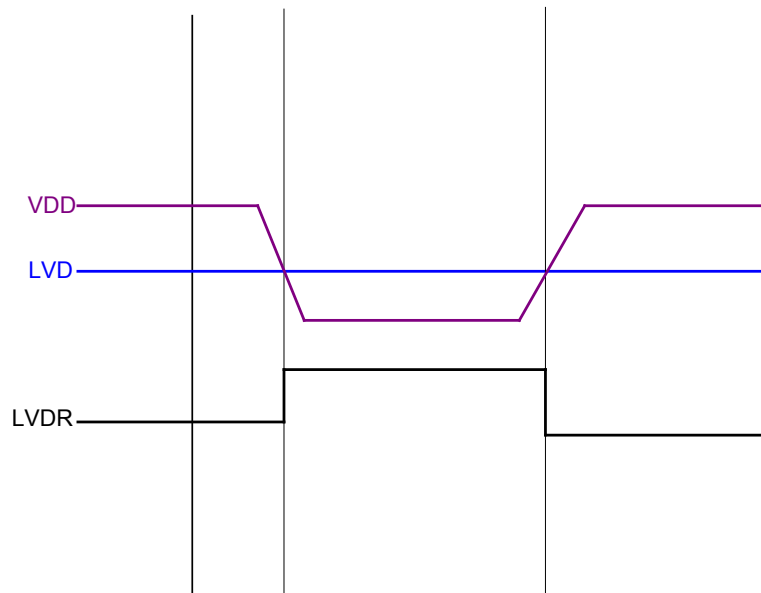

Low Voltage Detection Reset Control Register LVD_CTL (XFR: 0x02) Reset Value: A0h

Bit	Bit 7	Bit 6	Bit 5	Bit 4	Bit 3	Bit 2	Bit 1	Bit 0
Status	R/W	-	R/W	R/W	-	R/W	-	-
Name	LVD_PD	Reserved	LVD_LVL[1:0]		Reserved	LVD_RST_EN	Reserved	

Bit Number	Bit Mnemonic	Description
7	LVD_PD	1: Turn off Low Voltage Detection power 0: Turn on Low Voltage Detection power
6	Reserved	-
5-4	LVD_LVL[1:0]	Low Voltage Detection range: 11: 2.75V 00: 2.00V 10: reserved 01: reserved
3	Reserved	-
2	LVD_RST_EN	1: Enable Low Voltage Detection reset 0: Disable Low Voltage Detection reset

Bit Number	Bit Mnemonic	Description
1-0	Reserved	-

Note: The voltage range of Low Voltage Detection Reset has great tolerance. Please refer to Section 7.7 “Electrical Characteristics” for more details.

Reset Flag Register RESET_FLG (XFR: 0x03)
Reset Value: 01h

Bit	Bit 7	Bit 6	Bit 5	Bit 4	Bit 3	Bit 2	Bit 1	Bit 0
Status	W	R	R	R	R	R	R	R
Name	CLR_RST_FLG	PC_OVL_RST_FLG	ISP_RST_FLG	WDT_RST_FLG	NRST_FLG	LVD_RST_FLG	LVR_RST_FLG	POR_RST_FLG

Bit Number	Bit Mnemonic	Description
7	CLR_RST_FLG	1: Clear all Reset Flag
6	PC_OVL_RST_FLG	1: Reset source is from program counter overflow
5	ISP_RST_FLG	1: Reset source is from ISP
4	WDT_RST_FLG	1: Reset source is from Watchdog
3	NRST_FLG	1: Reset source is from External Reset pin
2	LVD_RST_FLG	1: Reset source is from Low Voltage Detection Reset
1	LVR_RST_FLG	1: Reset source is from Low Voltage Reset
0	POR_RST_FLG	1: Reset source is from External Power Reset

Note: For more details, please refer to Section 5.7 “Reset”.

6.14 Emulated E²PROM

The WT56F108 can use Flash PROM space to emulate E²PROM, and the storage address ranges from: 0x1800 ~ 0x1EFF (1792 bytes).

Due to the manufacturing process, WT56F108 is allowed to re-write data to the flash without erasing Flash first.

* Please note that the power voltage is limited to 2.4V to 3.6V.

E²PROM Enable Register 1 EER_EN1[3:0] (XFR: 0xE0)

Reset Value: 00h

Bit	Bit 7	Bit 6	Bit 5	Bit 4	Bit 3	Bit 2	Bit 1	Bit 0
Status	-	-	-	-	W	W	W	W
Name	Reserved				EER_EN1[3:0]			

Bit Number	Bit Mnemonic	Description
7-4	Reserved	-
3-0	EER_EN1[3:0]	When EER_EN1[3:0] = '1010' and EER_EN2[3:0] = '0101', the E ² PROM function is enabled.

-: unimplemented.

E²PROM Enable Register 2 EER_EN2[3:0] (XFR: 0xE1)

Reset Value: 00h

Bit	Bit 7	Bit 6	Bit 5	Bit 4	Bit 3	Bit 2	Bit 1	Bit 0
Status	-	-	-	-	W	W	W	W
Name	Reserved				EER_EN2[3:0]			

Bit Number	Bit Mnemonic	Description
7-4	Reserved	-
3-0	EER_EN2[3:0]	When EER_EN2[3:0] = '0101' and EER_EN1[3:0] = '1010', the E ² PROM function is enabled.

-: unimplemented.

E²PROM Address Low Bytes Register EER_ADDR[7:0] (XFR: 0xE2)

Reset Value: FFh

Bit	Bit 7	Bit 6	Bit 5	Bit 4	Bit 3	Bit 2	Bit 1	Bit 0
Status	R/W	R/W	R/W	R/W	R/W	R/W	R/W	R/W
Name	EER_ADDR[7:0]							

Bit Number	Bit Mnemonic	Description
7-0	EER_ADDR[7:0]	EER_ADDR[7:0] address setting, paired with EER_ADDR[10:8] to form a 11-bit address

E²PROM Address High Bytes Register EER_ADDR[11:8] (XFR: 0xE3)

Reset Value: 07h

Bit	Bit 7	Bit 6	Bit 5	Bit 4	Bit 3	Bit 2	Bit 1	Bit 0
Status	-	-	-	-	-	R/W	R/W	R/W
Name	Reserved					EER_ADDR[10:8]		

Bit Number	Bit Mnemonic	Description
7-3	Reserved	-
2-0	EER_ADDR[10:8]	EER_ADDR[10:8] address setting, paired with EER_ADDR[7:0] to form a 11-bit address

-: unimplemented.

E²PROM Control Register EER_TCTL[3:0] (XFR: 0xE4)
Reset Value: 00h

Bit	Bit 7	Bit 6	Bit 5	Bit 4	Bit 3	Bit 2	Bit 1	Bit 0
Status	R/W	R/W	-	W	-	-	-	-
Name	ERR_WRFail	ERR_BYFAIL	Reserved	EER_PROG	Reserved			

Bit Number	Bit Mnemonic	Description
7	ERR_WRFail	1: Programming function write operation fail flag CPU write 0 to clear this flag
6	ERR_BYFAIL	1: Programming function write operation busy overtime flag CPU write 0 to clear this flag
5	Reserved	-
4	EER_PROG	1: Programming function program (1 Byte) (auto-cleared as 0) 0: No program
3-0	Reserved	-

-: unimplemented.

E²PROM Data Register EER_DAT0[7:0] (XFR: 0xE8)
Reset Value: 00h

Bit	Bit 7	Bit 6	Bit 5	Bit 4	Bit 3	Bit 2	Bit 1	Bit 0
Status	W	W	W	W	W	W	W	W
Name	EER_DATA[7:0]							

Bit Number	Bit Mnemonic	Description
7-0	EER_DATA[7:0]	E ² PROM Data Register

Note:

- 1 · In programming E²PROM, all functions are halt state of 8052.
- 2 · It takes 500 μ sec to programming E²PROM while working at 3.3V.

E²PROM Address Setting Range

Flash address	EER_ADDR[10:8]	EER_ADDR[7:0]	Programming range
0x1800	000	0x00~0xFF	0x1800~ 0x18FF
0x1900	001	0x00~0xFF	0x1900~ 0x19FF
0x1A00	010	0x00~0xFF	0x1A00~ 0x1AFF
0x1B00	011	0x00~0xFF	0x1B00~ 0x1BFF
0x1C00	100	0x00~0xFF	0x1C00~ 0x1CFF
0x1D00	101	0x00~0xFF	0x1D00~ 0x1DFF
0x1E00	110	0x00~0xFF	0x1E00~ 0x1EFF

E²PROM Enable Flow chart:

Programming function:

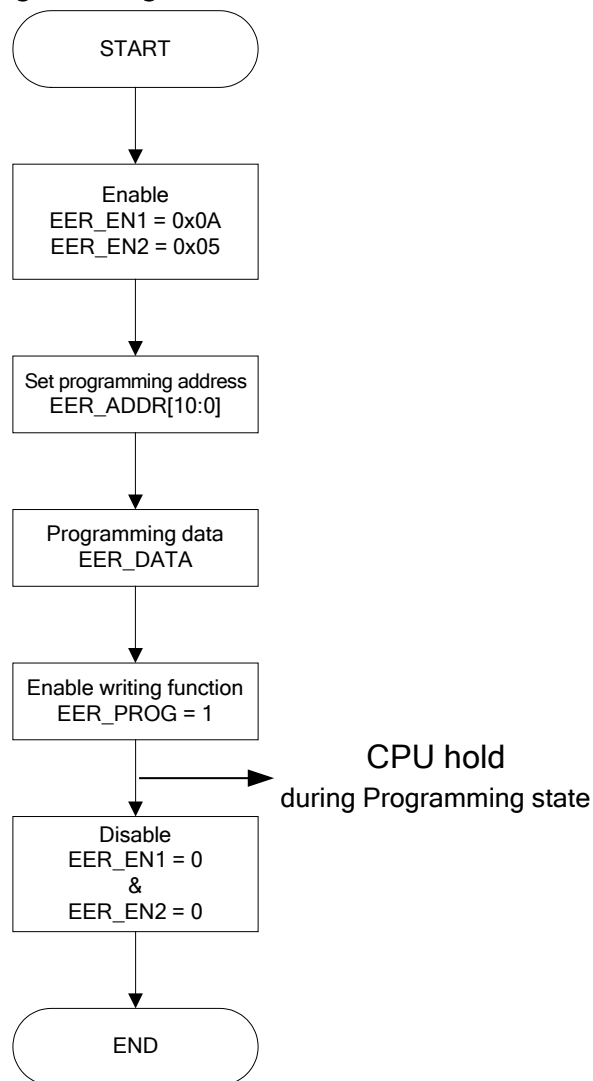

6.15 Code Option

Code Block located in the last eight bytes of Flash ROM for storing customer ID and IC configuration with address listed as the following table.

If this function is not enabled, please reserve the space of these eight bytes, and fill it with 0xFF.

If the function is enabled, WT56F108 will auto reload the code option at each reset. Please refer to the Sequence Diagram as listed below.

Address	Bit Number	Description
1FF8H	7-0	= AFH, enable Code Option = FFH, disable Code Option Default value 0xFF
1FF9H	7-0	Customer ID 1, mapping to XFR: CSM_ID1 = 0x0D[7:0] Default value 0xFF: code can be assigned by SWUT ISP software programming
1FFCH	7-0	Flash memory content protection: it is an individual setting, and will not be turned off even if Code Option is disabled. = 5AH flash memory cannot be read = A5H flash memory cannot be written into Default value 0xFF: Flash can read/write (by code encryption to achieve the same protection)
General Purpose I/O Complex Function Options Setting:		
1FFDH	7-2	Reserved
	1	Mapping to XFR: GPF1_FUN_SLT = 0x2DH[3:2] 1: select GPIOF0, GPIOF1 as crystal oscillator pins of path 2 0: select GPIOA5, GPIOA4 as crystal oscillator pins of path 1
	0	Mapping to XFR: GPA5_FUN_SLT = 0x25H[2] 1: select the external crystal oscillator pins as path 1 0: general-purpose I/O (default)
Oscillator Initialization and Driving Ability Options Setting:		
1FFEH	7-6	Reserved
	5-4	Mapping to XFR: SOURCE_CLK_SLT[1:0] = 0x05H[3:2]; SOURCE clock 00: internal 12 MHz RC oscillator (default) 01: external DC ~ 16 MHz crystal oscillator 10: internal 32 kHz RC oscillator 11: reserved
	3-1	Mapping to XFR: CRY_12M_DR[1:0] = 0x08H[3:1]; external crystal oscillator driving ability selection 000: select 32.768 kHz crystal oscillator (VDD > 2.4V) 001: select 32.768 kHz crystal oscillator 010: select 100 kHz crystal oscillator 100: select 1 MHz ~ 12 MHz crystal oscillator (default) 110: select 12 MHz ~ 16 MHz crystal oscillator
	0	Mapping to XFR: SLT_CRYSTAL = 0x08H[0]; crystal oscillator input pins selection 1: the crystal oscillator input pins of path 2, MOSCI2 (GPIOF0), MOSCO2 (GPIOF1) 0: the crystal oscillator input pins of path 1, MOSCI1 (GPIOA5), MOSCO1 (GPIOA4) (default)

Address	Bit Number	Description
All Oscillator Power Switch Options Setting:		
1FFFH	7-5	Reserved
	4	Mapping to XFR: IRC_12M_PD1 = 0x07H[4] 1: turn off partial power of internal 12 MHz RC oscillator 0: turn on partial power of internal 12 MHz RC oscillator (default)
	3	Mapping to XFR: IRC_12M_PD2 = 0x07H[3] 1: turn off all power of internal 12 MHz RC oscillator 0: turn on all power of internal 12 MHz RC oscillator (default)
	2	Mapping to XFR: IRC_32K_PD = 0x07H[2] 1: turn off the power of internal 32 kHz RC oscillator 0: turn on the power of internal 32 kHz RC oscillator (default)
	1	Mapping to XFR: CRY_12M_PD = 0x07H[1] 1: Turn off external 12 MHz ~ 32 kHz crystal oscillator (default) 0: Turn on external 12 MHz ~ 32 kHz crystal oscillator
	0	Reserved

Note: Code option setting would be overwritten by program setting, it is recommended to use the program to set the code option. Please refer to the next page for code option setting examples and code example program.

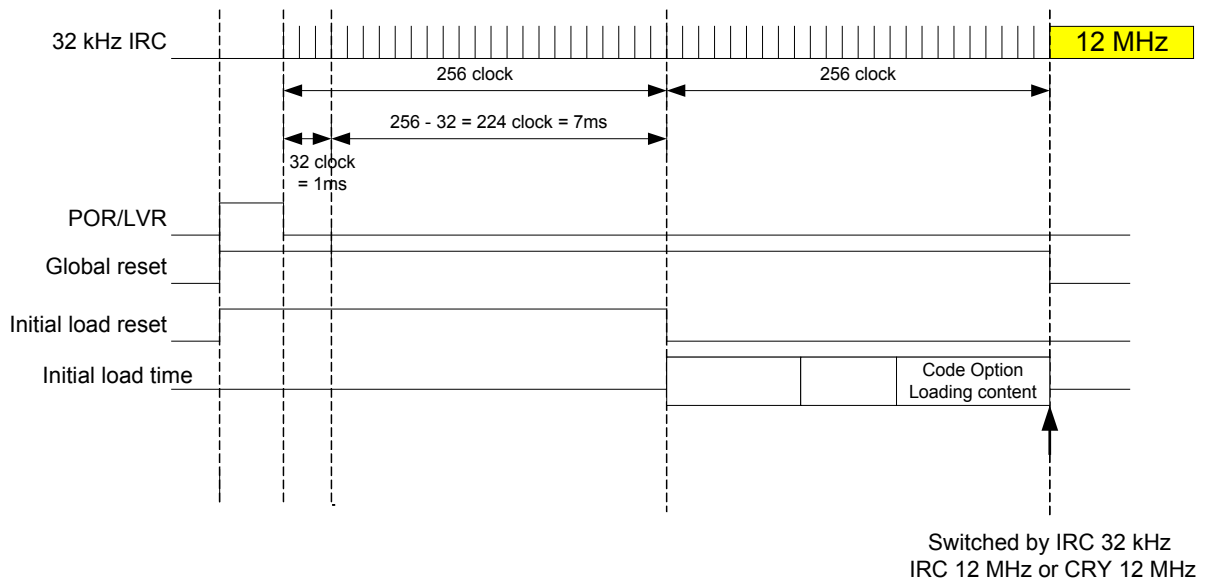

WT56F108 Code Option example:

```

;-----
; This Code: CodeOption108.A51 is for WT56F108 Code Option Setting
;-----
#define OPTION_ON          1
#define OPTION_OFF        0
;;Default OFF Code Option
#define WT56F108_CODE_OPTION OPTION_ON

#if(WT56F108_CODE_OPTION==OPTION_ON)
;;Load Code option switch
CSEG    AT 0x1FF8
DB    10101111B ;;0xAF: load code option

;;Customer ID 1 default 0xFF
CSEG    AT 0x1FF9
DB    11111111B

;;Flash Protect Read/Write
CSEG    AT 0x1FFC
;;Flash memory content protection:
;;default 0xFF select no protection MCU can read/write
;;bit7-0 = 5AH flash memory cannot be read
;;bit7-0 = A5H flash memory cannot be written into(For one time programming)
DB    11111111B

;;Crystal GPIO setting
CSEG    AT 0x1FFD
;;bit7 NC default 0
;;bit6 NC default 0
;;bit5 NC default 0
;;bit4 NC default 0
;;bit3 NC default 0
;;bit2 NC default 0
;;bit1 Mapping to XFR: GPF1_FUN_SLT 0x2DH[3:2]
;;default 0
;;1: MOSCO2
;;0: GPIO
;;bit0 Mapping to XFR: GPA5_FUN_SLT 0x25H[2]
;;default 0
;;1: MOSCI1
;;0: GPIO

DB    0000000B ;;default

;;Source Clock and Crystal drive setting
CSEG    AT 0x1FFE
;;bit7 NC default 0
;;bit6 NC default 0
;;bit5-4 Mapping to XFR: SOURCE_CLK_SLT[1:0] 0x05H[3:2]; initialization value of main oscillator
;;default 00
;;00: SOURCE clock = internal 12 MHz RC oscillator
;;01: SOURCE clock = external 1 MHz ~ 16 MHz crystal oscillator

```

```
;;10: SOURCE clock = internal 32 kHz RC oscillator
;;11: SOURCE clock = reserve
;;bit3-1 Mapping to XFR: CRY_12M_DR[2:0] 0x08H[3:1]; oscillator driving ability selection
;;default 100
;;000: select 32.768 kHz crystal oscillator (VDD > 2.4V)
;;001: select 32.768 kHz crystal oscillator
;;010: select 100 kHz crystal oscillator
;;100: select 1 MHz ~ 12 MHz crystal oscillator
;;110: select 12 MHz ~ 16 MHz crystal oscillator
;;bit0 Mapping to XFR: SLT_CRYSTAL 0x08H[0]; crystal pin select
;;default 0
;;1: MOSCI2(GPIOF0), MOSCO2(GPIOF1)
;;0: MOSCI1(GPIOA5), MOSCO1(GPIOA4)
DB 00001000B ;; default
```

```
;;Crystal Power setting
CSEG AT 0x1FFF
;;bit7 NC default 0
;;bit6 NC default 0
;;bit5 NC default 0
;;bit4 Mapping to XFR: IRC_12M_PD1 0x07H[4] default turn on
;;1: turn off partial power of internal 12 MHz RC oscillator
;;0: turn on partial power of internal 12 MHz RC oscillator
;;bit3 Mapping to XFR: IRC_12M_PD2 0x07H[3] default turn on
;;1: turn off all power of internal 12 MHz RC oscillator
;;0: turn on all power of internal 12 MHz RC oscillator
;;bit2 Mapping to XFR: IRC_32K_PD 0x07H[2] default turn on
;;1: turn off the power of internal 32 kHz RC oscillator
;;0: turn of the power of internal 32 kHz RC oscillator
;;bit1 Mapping to XFR: CRY_12M_PD 0x07H[1] default turn off
;;1: Turn off external 12 MHz ~ 32 KHz crystal oscillator
;;0: Turn on external 12 MHz ~ 32 KHz crystal oscillator
;;bit0 NC default 0
DB 00000010B ;; default
```

```
#else
CSEG AT 0x1FF8
DB 11111111B
CSEG AT 0x1FF9
DB 11111111B
CSEG AT 0x1FFA
DB 11111111B
CSEG AT 0x1FFB
DB 11111111B
CSEG AT 0x1FFC
DB 11111111B
CSEG AT 0x1FFD
DB 11111111B
CSEG AT 0x1FFE
DB 11111111B
CSEG AT 0x1FFF
DB 11111111B
#endif
```

Customer ID1 mapped to the Customer Code Registers, please refer to the following customer code register.

Customer Code Register CSTM_ID1 (XFR: 0x0D)								Reset Value: FFh
Bit	Bit 7	Bit 6	Bit 5	Bit 4	Bit 3	Bit 2	Bit 1	Bit 0
Status	R	R	R	R	R	R	R	R
Name	CSTM_ID1							

Bit Number	Bit Mnemonic	Description
7-0	CSTM_ID1	Customer code

Note: WT56F108 code option provides one byte (8 bits) available for customer to set, reading are taken in by the program storage area after each Reset.

The following registers is described in the previous section, and now is set for the Code Option registers mapped in the General-purpose I/O Complex Function options, including the option settings of the crystal oscillator pins and crystal oscillator sources.

0x25, 0x2D, 0x05, 0x07, 0x08 registers again described as below.

General-purpose I/O Port A Complex Function Setting Register 1 GPIOA_FUN1 (XFR: 0x25)								Reset Value: 00h
Bit	Bit 7	Bit 6	Bit 5	Bit 4	Bit 3	Bit 2	Bit 1	Bit 0
Status	R/W	R/W	-	-	-	R/W	-	-
Name	GPA7_FUN_SLT[1:0]		Reserved			GPA5_FUN_SLT	Reserved	

Bit Number	Bit Mnemonic	Description
7-6	GPA7_FUN_SLT[1:0]	Set GPIOA7DH complex function 00: GPIO/ETMIA/IRQ0 (default) 01: RXA, RX of path A of UART (select RXA, and auto define GPIOA6DH as TXA) 10: Reserved 11: P00 output/input (mapping to 8052 P0.0)
5-3	Reserved	-
2	GPA5_FUN_SLT	Set GPIOA5DH complex function 1: MOSC11 (served as the Crystal oscillator input pins of path 1, and will auto define GPIOA4DH as the oscillator output pin (MOSCO1) instead of GPIO function) 0: GPIO (default), and meanwhile GPIOA4DH will be set as GPIO function. Code option can be selected by 6.15 code option select
1-0	Reserved	-

-. unimplemented.

Notes: The setting of using External Crystal Oscillator as SOURCE clock (using Crystal Oscillator as the input pins of path 1):

1. Select Crystal Oscillator as the input pins of path 1: MOSC11, MOSCO1. (XFR 0x08 SLT_CRYSTAL = 0)
2. Set GPIOA5 and GPIOA4 as Input port. (XFR 0x10 GPIOA_OE[5:4])
3. GPIOA5 and GPIOA4 disable internal pull high resistor. If enable pull high resistor will result in oscillator outputs unstable frequency. (XFR 0x1E GPIOA_PHN[5:4])

4. Set GPIOA5 and GPIOA4 as Crystal Oscillator pins. (XFR 0x25 GPA5_FUN_SLT)
5. Set the driving ability of External Main Crystal Oscillator. (XFR 0x08 CRY_12M_DR[2:0])
6. Power on External Crystal Oscillator switch. (XFR 0x07 CRY_12M_PD)
7. Switch SOURCE clock to External Crystal Oscillator. (XFR 0x05 SOURCE_CLK_SLT[1:0])

General-purpose I/O port F Complex Function Setting Register2 GPIOF_FUN2 (XFR: 0x2D) Reset Value: 00h

Bit	Bit 7	Bit 6	Bit 5	Bit 4	Bit 3	Bit 2	Bit 1	Bit 0
Status	-	R/W	-	R/W	R/W	R/W	-	R/W
Name	Reserved	GPF3_FUN_SLT	Reserved	GPF2_FUN_SLT	GPF1_FUN_SLT[1:0]		Reserved	GPF0_FUN_SLT

Bit Number	Bit Mnemonic	Description
7	Reserved	-
6	GPF3_FUN_SLT	Set GPIOF3 complex function 1: COM3, LCD Common 3 0: GPIO (default)
5	Reserved	-
4	GPF2_FUN_SLT	Set GPIOF2 complex function 1: COM2, LCD Common 2 0: GPIO (default)
3-2	GPF1_FUN_SLT[1:0]	Set GPIOF1 complex function 00: GPIO (default) 01: COM1, LCD common 1 10: MOSCO2, served as the Crystal oscillator output pin of path 2, and will auto define GPIOF0 as the crystal oscillator input pins (MOSCI2) instead of GPIO function. 11: reserved Default value can be selected by 6.15 Code Option
1	Reserved	-
0	GPF0_FUN_SLT	Set GPIOF0 complex function 1: COM0, LCD Common 0 0: GPIO (default)

-: unimplemented.

Notes: The setting of using External Crystal Oscillator as SOURCE clock (using Crystal Oscillator as the input pins of path 2):

1. Select Crystal Oscillator as the input pins of path 2: MOSCI2, MOSCO2. (XFR 0x08 SLT_CRYSTAL = 1)
2. Set GPIOF1 and GPIOF0 as Input port. (XFR 0x15 GPIOF_OE[1:0])
3. GPIOF1 and GPIOF0 disable internal pull high resistor. If enable pull high resistor will result in oscillator outputs unstable frequency. (XFR 0x20 GPIOF_PHN)
4. Set GPIOF1 and GPIOF0 as Crystal Oscillator pin. (XFR 0x2D GPF1_FUN_SLT[1:0])
5. Set the driving ability of External Main Crystal Oscillator. (XFR 0x08 CRY_12M_DR[2:0])
6. Power on External Crystal Oscillator switch. (XFR 0x07 CRY_12M_PD)
7. Switch SOURCE clock to External Crystal Oscillator. (XFR 0x05 SOURCE_CLK_SLT[1:0])

System Clock Source Control Register SOURCE_CLK_SLT (XFR: 0x05)
Reset Value: A1h

Bit	Bit 7	Bit 6	Bit 5	Bit 4	Bit 3	Bit 2	Bit 1	Bit 0
Status	-	-	-	-	R/W	R/W	R/W	R/W
Name	Reserved			SOURCE_CLK_SLT[1:0]		MCU_CLK_SLT[1:0]		

Bit Number	Bit Mnemonic	Description
7-4	-	Must be equal to "1010", otherwise bit [3:0] cannot be written into.
3-2	SOURCE_CLK_SLT[1:0]	Select SOURCE clock sources 00: internal 12 MHz RC oscillator (default) 01: external DC ~ 16 MHz crystal oscillator 10: internal 32 kHz RC oscillator 11: reserved Default value can be selected by section 6.15 Code Option
1-0	MCU_CLK_SLT[1:0]	MCU clock setting 00: MCU clock and System clock = SOURCE clock 01: MCU clock and System clock = SOURCE clock / 2 (default) 10: MCU clock and System clock = SOURCE clock / 4 11: MCU clock and System clock = SOURCE clock / 12

-: unimplemented.

Clock Source Control Register IRC_12M_PD (XFR: 0x07)
Reset Value: A2h

Bit	Bit 7	Bit 6	Bit 5	Bit 4	Bit 3	Bit 2	Bit 1	Bit 0
Status	-	-	-	R/W	R/W	R/W	R/W	-
Name	Reserved		IRC_12M_PD1	IRC_12M_PD2	IRC_32K_PD	CRY_12M_PD	Reserved	

Bit Number	Bit Mnemonic	Description
7-5	-	Must be equal to "101", otherwise bit[4:0] cannot be written into
4	IRC_12M_PD1	1: partial internal 12 MHz RC oscillator power is turned off (default value is not off) 0: not off Default value can be selected by section 6.15 Code Option
3	IRC_12M_PD2	1: all internal 12 MHz RC oscillator power is turned off (default value is not off) 0: not off Default value can be selected by section 6.15 Code Option
2	IRC_32K_PD	1: internal 32 kHz RC oscillator power is turned off (default value is not off) 0: not off Default value can be selected by section 6.15 Code Option
1	CRY_12M_PD	1: external 12 MHz ~ 32 kHz crystal oscillator power is turned off (default value is off) 0: not off Default value can be selected by section 6.15 Code Option
0	Reserved	-

-: unimplemented.

Oscillator Driver Control Register CRY_12M_DR[2:0] (XFR: 0x08)
Reset Value: 58h

Bit	Bit 7	Bit 6	Bit 5	Bit 4	Bit 3	Bit 2	Bit 1	Bit 0
Status	-	-	-	-	R/W	R/W	R/W	R/W
Name	Reserved			CRY_12M_DR[2:0]			SLT_CRYSTAL	

Bit Number	Bit Mnemonic	Description
7-4	-	Must be equal to "0101", otherwise, Bit[3:0] cannot be written into
3-1	CRY_12M_DR[2:0]	External oscillator driving ability setting 000: crystal oscillator with frequency of 32.768 kHz (VDD > 2.4V) 001: crystal oscillator with frequency of 32.768 kHz 010: crystal oscillator with frequency of 100 kHz 100: crystal oscillator with frequency of 1 MHz ~ 12 MHz (default) 110: crystal oscillator with frequency of 12 MHz ~ 16 MHz Default value can be selected by section 6.15 Code Option
0	SLT_CRYSTAL	Crystal Oscillator Input pin select 1: the crystal oscillator input pins of path 2: MOSCI2 (GPIOF0), MOSCO2 (GPIOF1) 0: the crystal oscillator input pins of path 1: MOSCI1 (GPIOA5), MOSCO1 (GPIOA4) Default value can be selected by section 6.15 Code Option

-: unimplemented.

6.16 Read Out Protection & Code Encryption

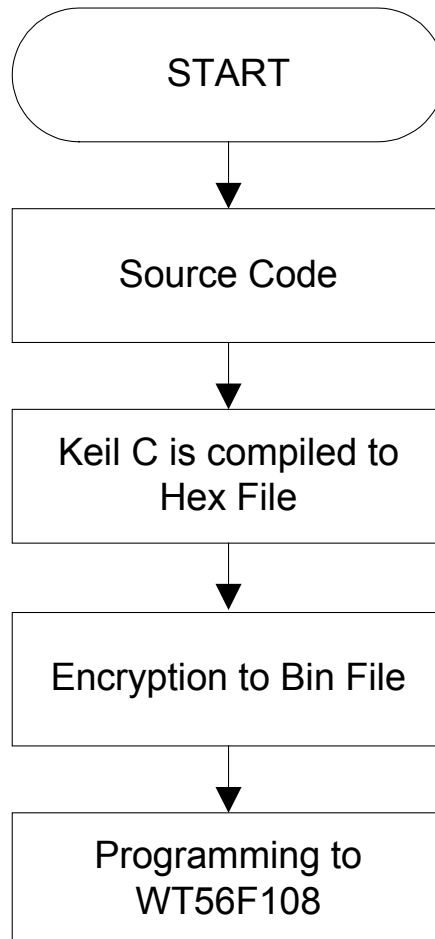

7. Electrical Characteristics

7.1 Absolute Maximum Ratings

Parameter	Symbol	Condition	Range	Units
D.C. Supply Voltage	V_{DD}		-0.3 ~ 3.6	V
Input Voltage	V_I		-0.3 to $V_{DD} + 0.3$	V
Output Voltage	V_O		-0.3 to $V_{DD} + 0.3$	V
Total current source by all GPIO	$\sum I_{OH}$		90@-40°C ~ +85°C	mA
Total current sink by all GPIO	$\sum I_{OL}$		90@-40°C ~ +85°C	mA
Ambient Temperature	T_A		-40 ~ 85	°C
Storage Temperature	T_{STG}		-60 ~ 125	°C

Note: Stresses above those listed may cause permanent damage to the devices.

7.2 Recommended Operating Parameters

Parameter	Symbol	Condition	Specification			Units
			Min	Typ.	Max	
Power Voltage	V_{DD}	$F_{main} = 12 \text{ MHz}$	2.4		3.6	V
Main Frequency	F_{main}	$V_{DD} = 2.4V \sim 3.6V$		12		MHz
Sub Frequency	F_{sub}	$V_{DD} = V_{DD}$		32.768		kHz
Operating Temperature	T_{OPR}		-40		85	°C
POR (Power on Reset) Level	V_{POR}	At $V_{DDTR} = 30ms$, $T_A = 25^\circ C$ (see table below)		1.7		V

(*): These parameters are presented for design guidance only and not tested or guaranteed.

Power On Reset (POR) Timing

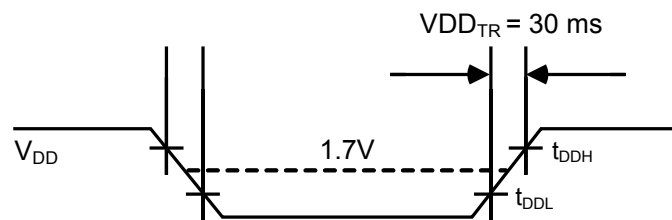

7.3 DC Electrical Characteristics ($V_{DD} = 1.8V \sim 3.6V, -40^{\circ}C \sim +85^{\circ}C$)

Parameter	Symbol	Condition	Specification			Units
			Min	Typ.	Max	
Schmitt Trigger from Low to High	V_{T+}	$V_{DD} = 1.8V \sim 3.6V$	$0.7 V_{DD}$		$V_{DD} + 0.3$	V
Schmitt Trigger from High to Low	V_{T-}	$V_{DD} = 1.8V \sim 3.6V$			$0.2 V_{DD}$	V
Output High Voltage (Note)	V_{OH2}	$I_{OH} = 2\text{ mA}$ at $V_{DD} = 3.3V$ GPIOB0 ~ GPIOB3, GPIOC0 ~ GPIOC7, GPIOD0 ~ GPIOD7, GPIOE0 ~ GPIOE7, GPIOF0 ~ GPIOF7, GPIOG0 ~ GPIOG7	$V_{DD} - 0.4$			V
	V_{OH6}	$I_{OH} = 6\text{ mA}$ at $V_{DD} = 3.3V$ GOIOA0 ~ GPIOA7, GPIOB4 ~ GPIOB7	$V_{DD} - 0.4$			
Output Low Voltage (Note)	V_{OL2}	$I_{OL} = 2\text{ mA}$ at $V_{DD} = 3.3V$ GPIOB0 ~ GPIOB3, GPIOC0 ~ GPIOC7, GPIOD0 ~ GPIOD7, GPIOE0 ~ GPIOE7, GPIOF0 ~ GPIOF7, GPIOG0 ~ GPIOG7			$V_{SS} + 0.4$	V
	V_{OL6}	$I_{OL} = 6\text{ mA}$ at $V_{DD} = 3.3V$ GOIOA0 ~ GPIOA7, GPIOB4 ~ GPIOB7			$V_{SS} + 0.4$	
Input Leakage Current ^(*)	I_{OZ}	$V_O = 0V$ or V_{DDV}		± 0.01	± 1	μA
Pull-up Resistor	R_{PH}	$V_{DD} = 3.3V, V_{PIN} = 0V$		50		$K\Omega$
Normal mode at 12 MHz Working Current	I_{VDD12M}	No load on output ($V_{DD} = 3.3V$, IRC12M on), peripheral off		7		mA
Normal mode at 6 MHz Working Current	I_{VDD6M}	No load on output ($V_{DD} = 3.3V$, IRC12M on), peripheral off		4		mA
Normal mode at 3 MHz Working Current	I_{VDD3M}	No load on output ($V_{DD} = 3.3V$, IRC12M on), peripheral off		3		mA
Normal mode at 1 MHz Working Current	I_{VDD1M}	No load on output ($V_{DD} = 3.3V$, IRC12M on), peripheral off		2		mA

Parameter	Symbol	Condition	Specification			Units
			Min	Typ.	Max	
Idle mode Working Current	$I_{VDD S1}$	No load on output ($V_{DD} = 3.3V$, mcuClk = stop, Peripheral clock = IRC12M), peripheral off		1.5		mA
Green mode Working Current	$I_{VDD S2}$	No load on output ($V_{DD} = 3.3V$, mcuClk = IRC32K, Peripheral clock = IRC32K, LVR off), peripheral off		30		μA
Sleep mode Working Current	$I_{VDD S3}$	No load on output ($V_{DD} = 3.3V$, mcuClk = stop, Peripheral clock = stop, LVR off), peripheral off		1		μA
LCD ON Working Current	I_{LCD}	No Load@3V		1.8		μA

(*): These parameters are presented for design guidance only and not tested or guaranteed.

Note: V_{OH2} / V_{OL2} pins maximum sink/source current are 8 mA; V_{OH6} / V_{OL6} pins maximum sink/source current are 24 mA.

7.4 AC Electrical Characteristics ($T_A = 25^\circ C$)

Parameter	Symbol	Pin/condition	Specification			Units
			Min	Typ.	Max	
Main Operation Frequency	F_{MCP}	X_{IN}	0.032			MHz
Main Crystal Stabilization Time(*)		$V_{DD} = 1.8V \sim 3.6V$ at 16 MHz		10		ms
		$V_{DD} = 1.8V \sim 3.6V$ at 12 MHz		10		ms
		$V_{DD} = 1.8V \sim 3.6V$ at 32768 Hz		5*		s
Interrupt Input High, Low Width (IRQx)	$t_{INT H}$, $t_{INT L}$	MCU clock = 12 MHz	167			ns
RESET Input Low Width	t_{RSL}	RST_NDF = 1, main clock = 12 MHz	334			ns

(*): These parameters are presented for design guidance only and not tested or guaranteed.

Input Timing for External Interrupts

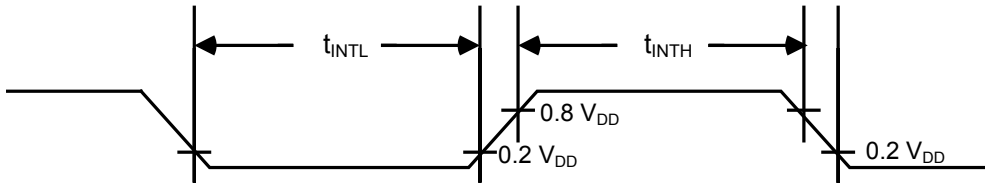

Input Timing for RESET

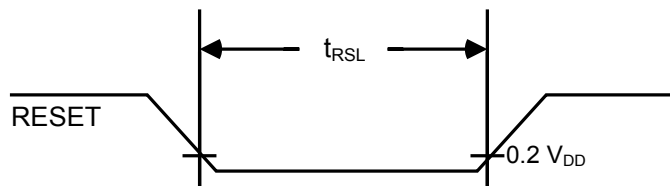

7.5 Internal 12 MHz RC Oscillator Temperature Tolerance table

Parameter	Symbol	Pin/condition	Specification			Units
			Min	Typ.	Max	
RC Oscillator Frequency	F_{RCH}	$V_{DD} = 3.3V$		12		MHz
RC Oscillator Frequency Tolerance	$\Delta F_{RCH}/F_{RCH}$	$V_{DD} = 3.0V \sim 3.6V$ F_{RCH} at $V_{DD} = 3.3V$		± 3		%
Ex-factory Frequency Tolerance(*)	$\Delta F_{RCH1}/F_{RCH}$	Without external oscillator for calibrating $25^{\circ}C @ 3.3V$		± 3		%
		Without external oscillator for calibrating $0^{\circ}C \sim 70^{\circ}C @ 3.3V$		± 5		%
		Without external oscillator for calibrating $-40^{\circ}C \sim 85^{\circ}C @ 3.3V$		± 7		%
		Without external oscillator for calibrating $-40^{\circ}C \sim 125^{\circ}C @ 3.3V$		± 10		%
		Without external oscillator for calibrating $1.8V \sim 3.6V @ 25^{\circ}C$		± 10		%
		With external oscillator for calibrating $-40^{\circ}C \sim 125^{\circ}C$				± 1

(*): These parameters are presented for design guidance only and not tested or guaranteed.

7.6 A/D Converting Characteristics (T_A = 25°C)

Parameter	Symbol	Pin/condition	Specification			Units
			Min	Typ.	Max	
Resolution				10		bit
Integral Nonlinearity Error (INL)	E _{IL}	AV _{REF} = V _{DD} = 3.3V			±6	LSB
Differential Nonlinearity Error (DNL)	E _{DL}	AV _{REF} = V _{DD} = 3.3V			±1.5	LSB
ENOB (Effective Number of Bits)		AV _{REF} = 3.3V ~ 2.4V		7.5		Bit
		AV _{REF} = 2.4V ~ 2V		7		Bit
		AV _{REF} = 2V ~ 1.8V		6.5		Bit
Analog Voltage Input Range	V _{ADCIN}		V _{SS}		V _{REF}	V
Conversion Time	T _{CT}	main clock = 12 MHz	14			ADC_clk
Reference Voltage ^(*)	AV _{REF}		1.8		V _{DD}	V
Ground Voltage ^(*)	AV _{SS}		V _{SS}		V _{SS} + 0.3	V
ADC Working Current ^(*)	I _{ADC}	AV _{REF} = V _{DD} = 3.3V		0.23		mA
		AV _{REF} = V _{DD} = 3.3V At Power Down mode			1	μA

(*): These parameters are presented for design guidance only and not tested or guaranteed.

7.7 Low Voltage Reset (LVR) & Low Voltage Detection Reset (LVDR) Electrical Characteristics

Parameter	Symbol	Pin/condition	Specification			Units
			Min	Typ.	Max	
LVR Voltage	V _{LVR}	T _A = 25°C		1.55		V
LVR/LVDR Working Current	I _{DDPR}	V _{DD} = 3.3V		20		μA
LVDR Response Time				20		μS
Low Voltage Detection Reset Range Tolerance				±12		%

7.8 Thermal Resistance Notice

Parameter	Symbol	Feature	Typ.	Units	Condition
TH01	θ_{JA}	Thermal Resistance (Junction to Air)	57	°C/W	44-pin LQFP package
TH02	θ_{JC}	Thermal Resistance (Junction to Case)	15	°C/W	44-pin LQFP package
TH03	TJMAX	Maximum Junction Temperature	125	°C	44-pin LQFP package

Parameter	Symbol	Feature	Typ.	Units	Condition
TH01	θ_{JA}	Thermal Resistance (Junction to Air)	57	°C/W	64-pin LQFP package
TH02	θ_{JC}	Thermal Resistance (Junction to Case)	15	°C/W	64-pin LQFP package
TH03	TJMAX	Maximum Junction Temperature	125	°C	64-pin LQFP package

8. Application Circuits

8.1 Power Supply

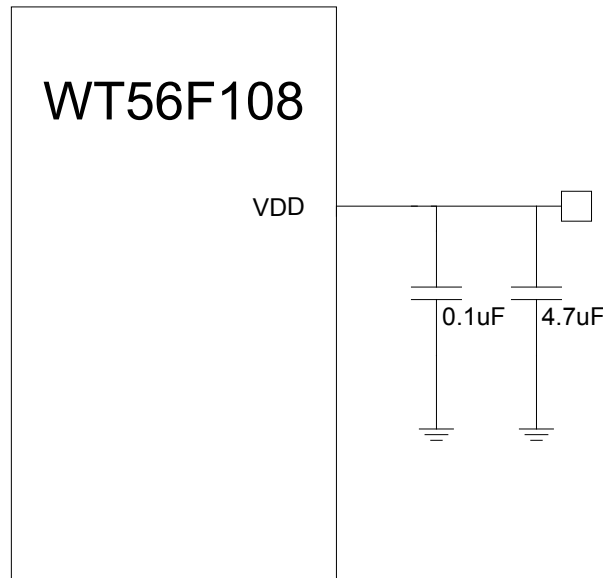

8.2 Oscillator Circuits

8.2.1 External 12 MHz Crystal Oscillator

Example

Crystal Oscillator	C1, C2 = 0pF ~ 68pF
Ceramic Resonator	C1, C2 = 0pF ~ 68pF

* The example load capacitor value(C1,C2,C3,C4) is common value but may not be appropriate for some crystal or ceramic resonator.

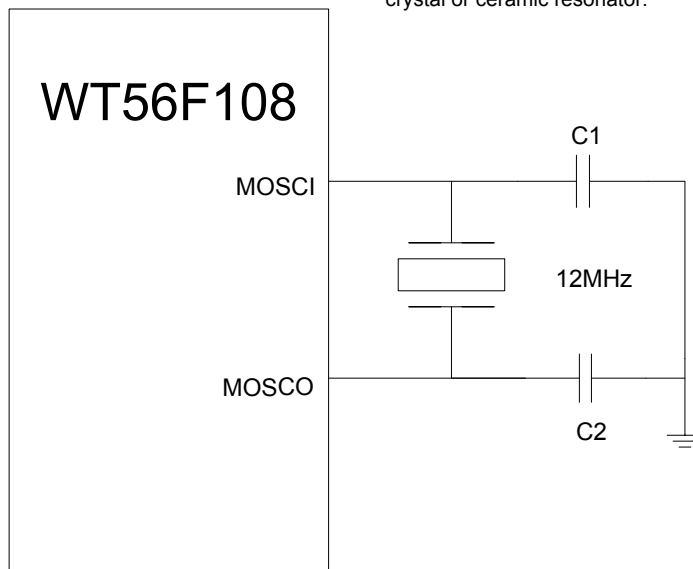

Note: WT56F108 has built-in internal RC oscillators, thus external crystal oscillators are not essential. If for more precise application, external crystal oscillator is available for use.

8.2.2 External 32.768 kHz Crystal Oscillator

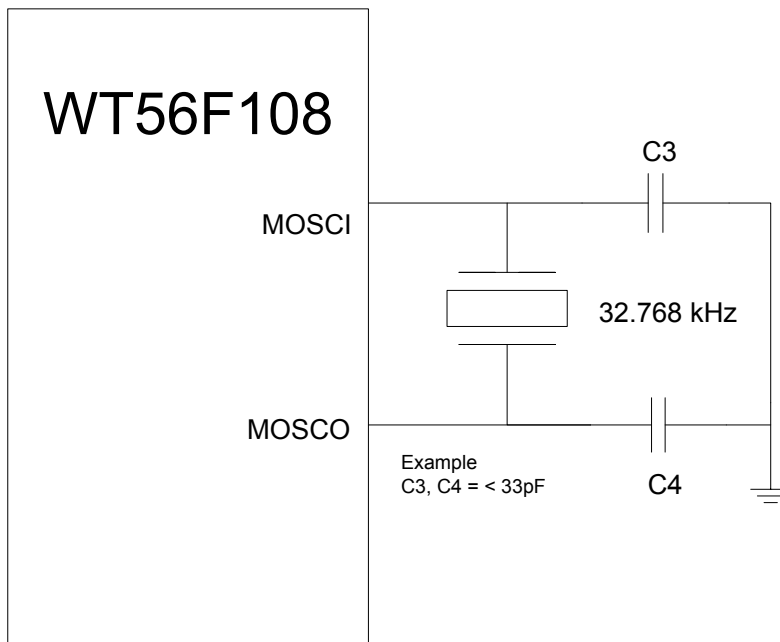

8.3 RESET Circuit

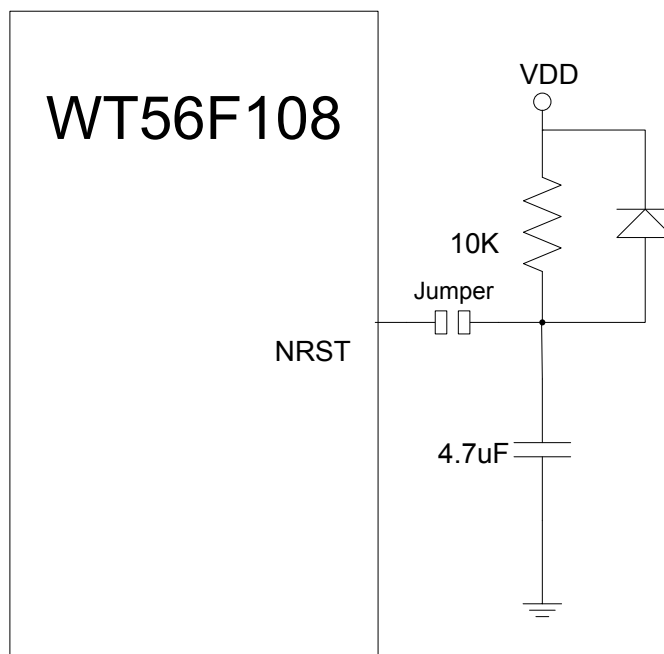

Note: Reset Circuit will affect programming process, and it requires adding Jumper for isolation.

8.4 Standard Circuit

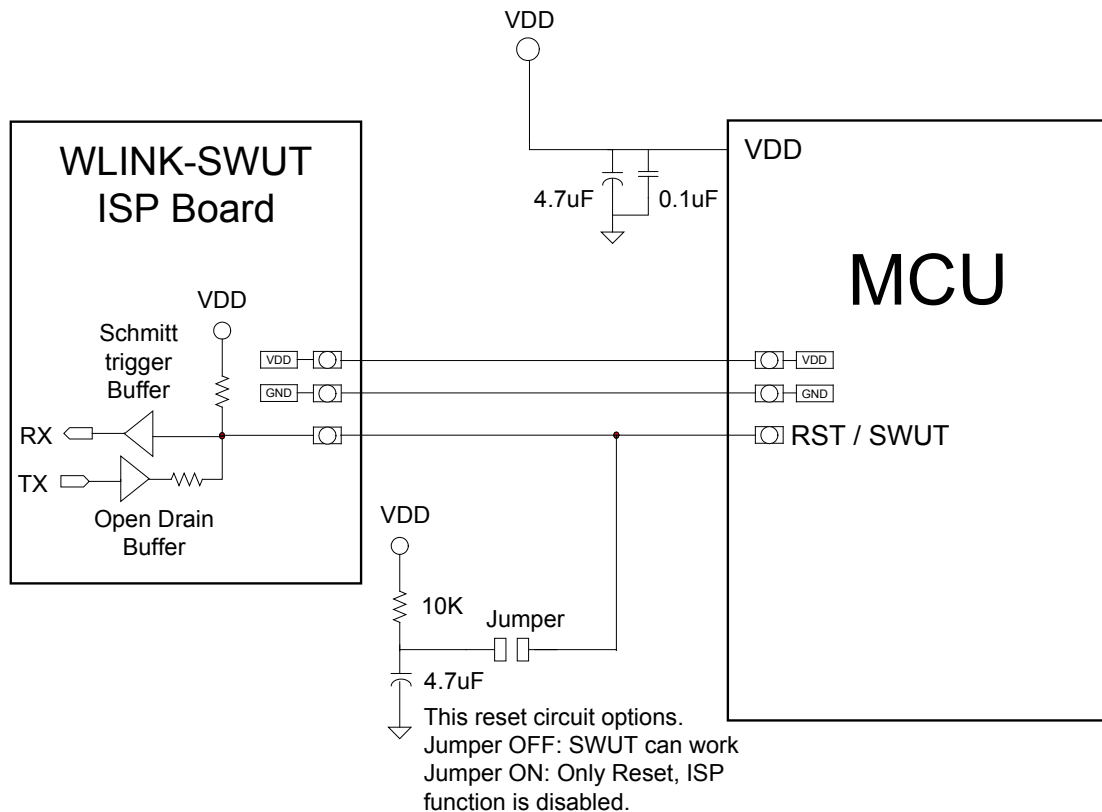

8.5 Development board circuits (4COM LCD)

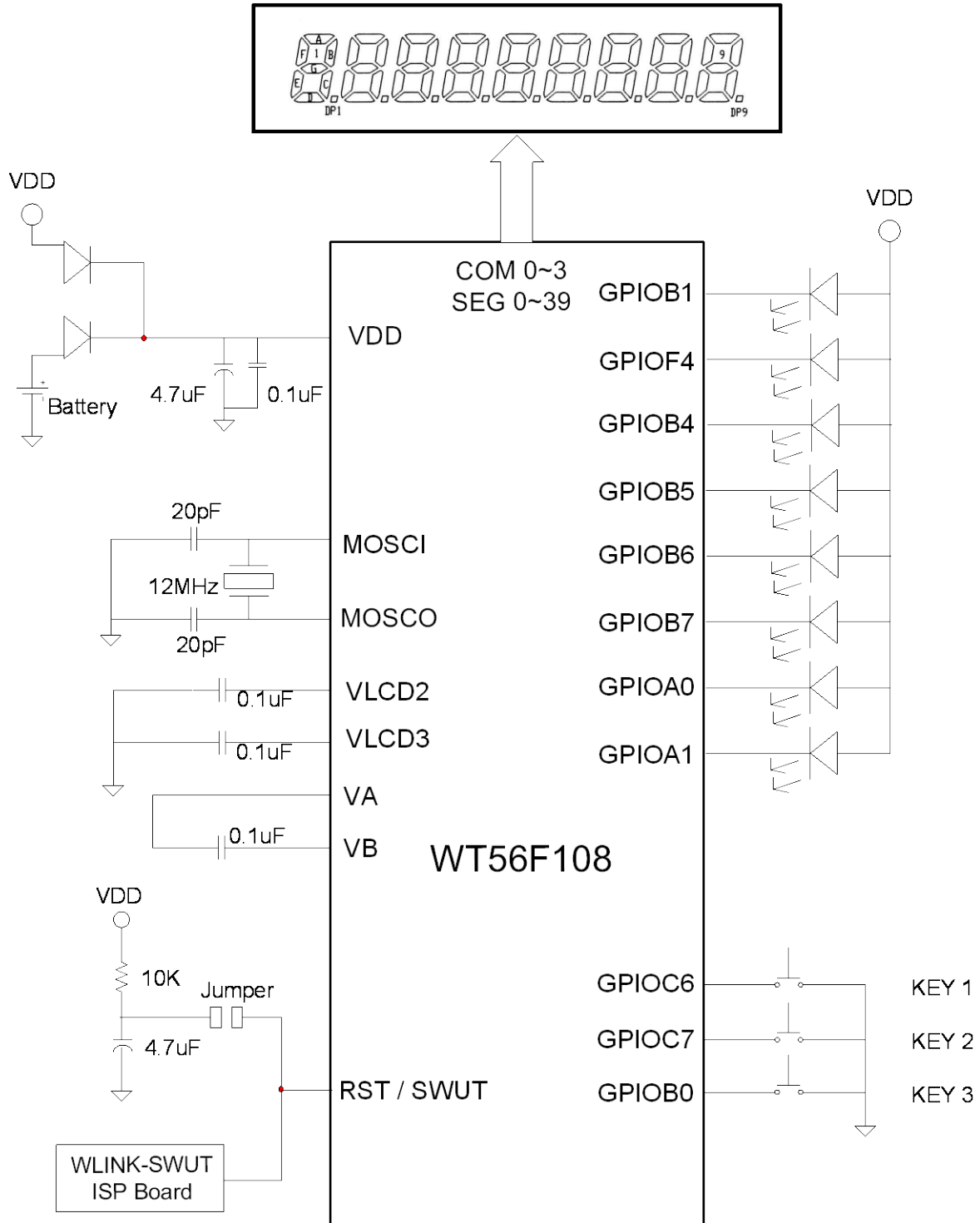

9. Product Naming Rule

WT	Consumption market	LCD function	Seed code (Family)	Flash Size (K Bytes)		Remarks
WT	5	1F	1	0	4	5: MCU/DSP embedded, used in general-purpose or consumption market related product. 1X: 8-bit MCU 1F: Flash type 8-bit MCU without LCD function
			5	1	6	
WT	5	6F	1	0	8	5: MCU/DSP embedded, used in general-purpose or consumption market related product. 6X: LCD back light module controller 6F: Flash type 8-bit MCU with LCD function
			2	1	6	

10. Ordering Information

Package Type	Package Outline	Part Number
64-pin LQFP	7mm x 7mm	WT56F108-RG64AWT
44-pin LQFP	10mm x 10mm	WT56F108-RG44AWT
SOP28	300 mil	WT56F108-SG28AWT
Wafer form or Chip form	-	WT56F108HXXXWT

11. Pad Diagram & Location Table

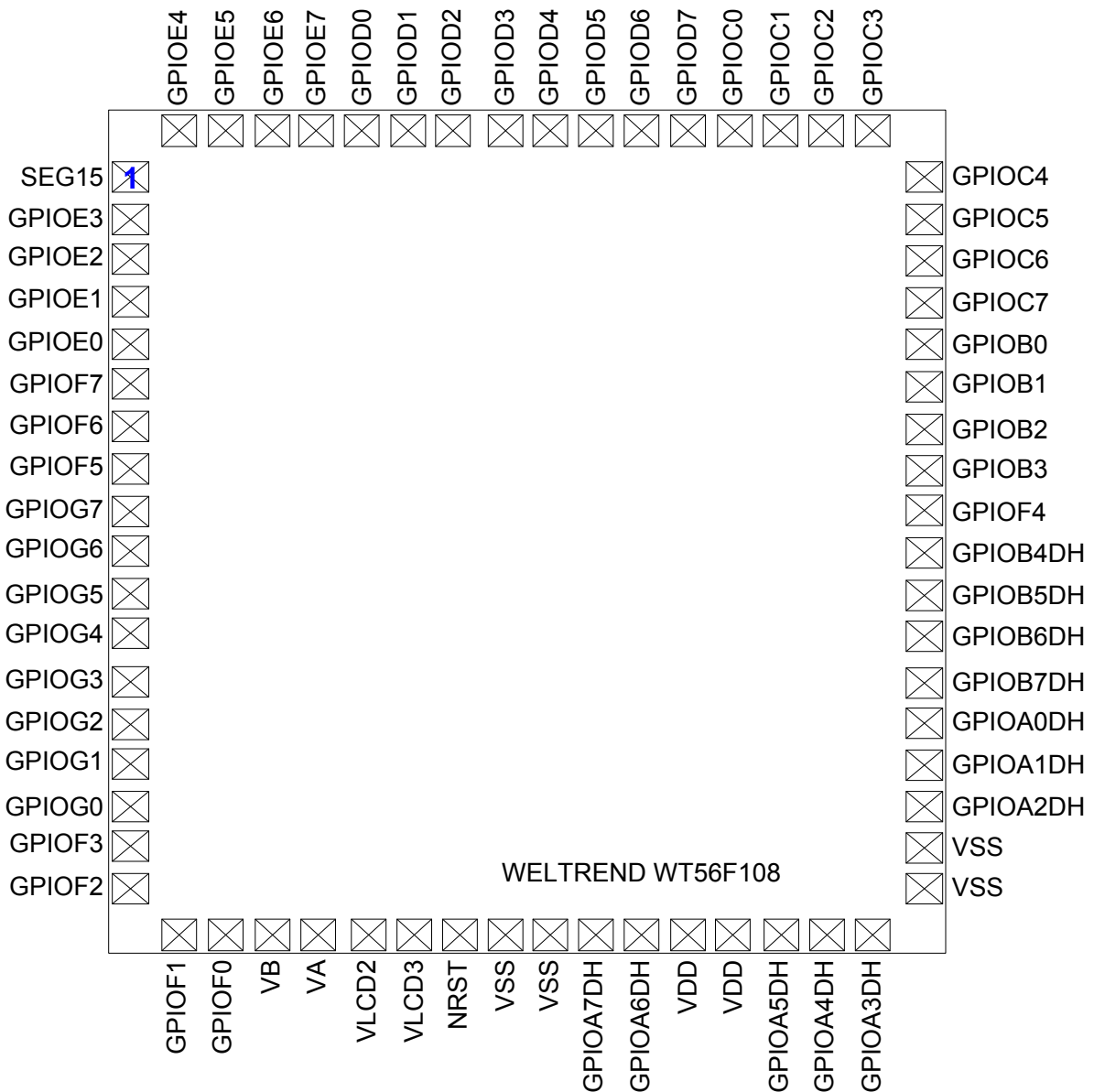

PAD Location

No	Name	X	Y	No	Name	X	Y
1	SEG15	67.5	2251.3	35	VSS	2142.5	198.7
2	GPIOE3	67.5	2131.3	36	VSS	2142.5	316.7
3	GPIOE2	67.5	2011.3	37	GPIOA2DH	2142.5	436.3
4	GPIOE1	67.5	1891.3	38	GPIOA1DH	2142.5	555.3
5	GPIOE0	67.5	1771.3	39	GPIOA0DH	2142.5	674.3
6	GPIOF7	67.5	1651.3	40	GPIOB7DH	2142.5	793.3
7	GPIOF6	67.5	1531.3	41	GPIOB6DH	2142.5	926.3
8	GPIOF5	67.5	1411.3	42	GPIOB5DH	2142.5	1045.3
9	GPIOG7	67.5	1291.3	43	GPIOB4DH	2142.5	1164.3
10	GPIOG6	67.5	1172.1	44	GPIOF4	2142.5	1283.3
11	GPIOG5	67.5	1052.1	45	GPIOB3	2142.5	1404.3
12	GPIOG4	67.5	932.1	46	GPIOB2	2142.5	1525.3
13	GPIOG3	67.5	797.5	47	GPIOB1	2142.5	1646.3
14	GPIOG2	67.5	678.3	48	GPIOB0	2142.5	1767.3
15	GPIOG1	67.5	559.1	49	GPIOC7	2142.5	1888.3
16	GPIOG0	67.5	439.9	50	GPIOC6	2142.5	2009.3
17	GPIOF3	67.5	320.7	51	GPIOC5	2142.5	2130.3
18	GPIOF2	67.5	198.7	52	GPIOC4	2142.5	2251.3
19	GPIOF1	198.7	67.5	53	GPIOC3	2011.3	2382.5
20	GPIOF0	319.7	67.5	54	GPIOC2	1890.1	2382.5
21	VB	440.7	67.5	55	GPIOC1	1769.35	2382.5
22	VA	558.7	67.5	56	GPIOC0	1649.35	2382.5
23	VLCD2	692.7	67.5	57	GPIOD7	1529.35	2382.5
24	VLCD3	811.7	67.5	58	GPIOD6	1409.35	2382.5
25	NRST	930.7	67.5	59	GPIOD5	1289.35	2382.5
26	VSS	1049.7	67.5	60	GPIOD4	1169.35	2382.5
27	VSS	1168.7	67.5	61	GPIOD3	1049.35	2382.5
28	GPIOA7DH	1287.7	67.5	62	GPIOD2	915.35	2382.5
29	GPIOA6DH	1406.7	67.5	63	GPIOD1	794.7	2382.5
30	VDD	1525.7	67.5	64	GPIOD0	675.5	2382.5
31	VDD	1644.7	67.5	65	GPIOE7	556.3	2382.5
32	GPIOA5DH	1771.7	67.5	66	GPIOE6	437.1	2382.5
33	GPIOA4DH	1890.7	67.5	67	GPIOE5	317.9	2382.5
34	GPIOA3DH	2011.3	67.5	68	GPIOE4	198.7	2382.5

Notes:

1. The origin of pad location shown here is at lower-left corner of die.
2. PAD Window: 86um x 86um and use circuit under PAD
3. To stabilize the supply voltages, please connect 0.1uF and 4.7uF bypass capacitors between VDD and VSS.
4. All VDD pin need connect together. (No: 30,31)
5. All VSS pin need connect together. (No: 26,27,35,36)

12. Package Dimension

12.1 64-Pin LQFP

1. Package Outline

Low-Profile Quad Flat Package

LQFP-64 PIN

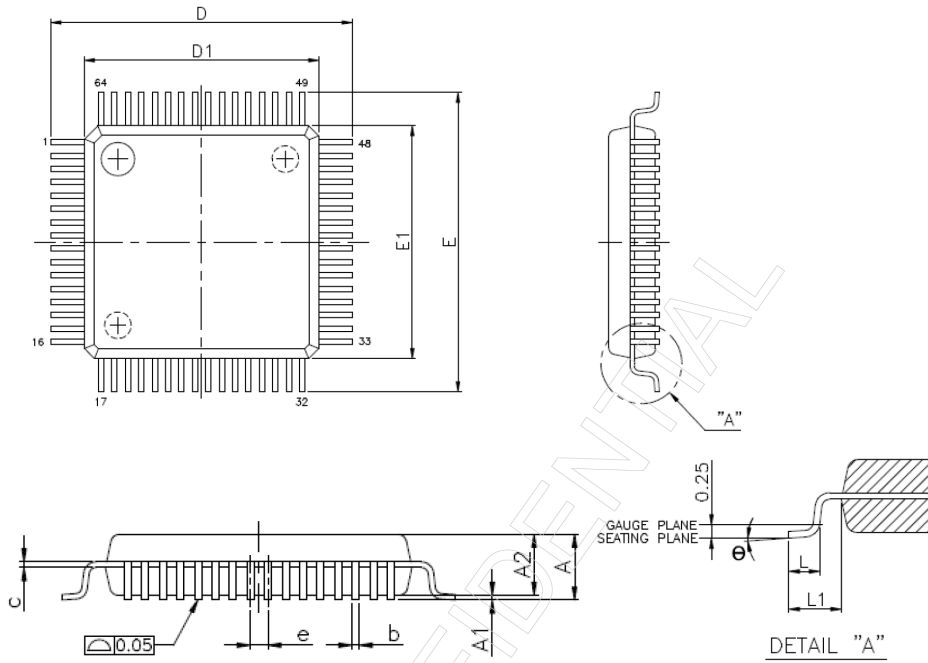

SYMBOLS	MIN	NOR	MAX
A	-	-	1.60
A1	0.05	-	0.15
A2	1.35	1.40	1.45
b	0.13	0.18	0.23
c	0.09	-	0.20
D	9.00 BSC		
D1	7.00 BSC		
e	0.40 BSC		
E	9.00 BSC		
E1	7.00 BSC		
L	0.45	0.60	0.75
L1	1.00 REF		
θ°	0	3.5	7

UNIT: mm

NOTES:

- JEDEC outline : MS-026 BBD
- Dimensions "D1" and "E1" do not include mold protrusion. Allowable protrusion is 0.25mm per side. "D1" and "E1" are maximum plastic body size dimensions including mold mismatch.
- Dimension "b" does not include dambar protrusion. Allowable dambar protrusion shall not cause the lead width to exceed the maximum "b" dimension by more than 0.08mm.

PREPARE	Cynthia	DATE: 2012/7/27
CHECK	Lawrence	DATE: 2012/7/27
APPROVE	Eric	DATE: 2012/7/27

12.2 44-Pin LQFP

Low-Profile Quad Flat Package

LQFP-44 PIN

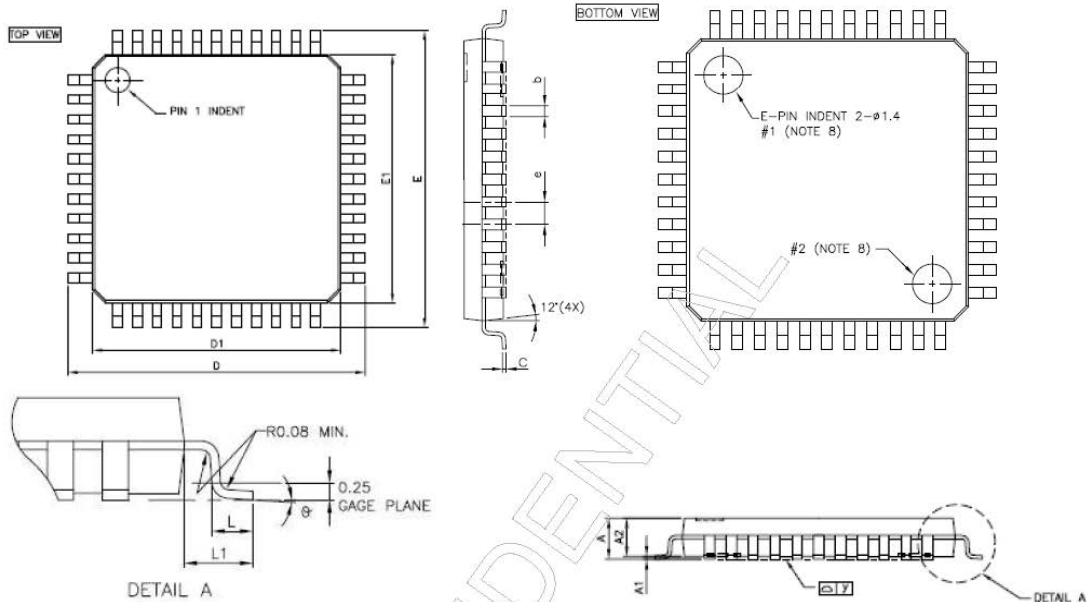

SYMBOLS	MIN	NOR	MAX
A	-	-	1.60
A1	0.05	-	0.15
A2	1.35	1.40	1.45
b	0.30	0.37	0.45
C	0.09	-	0.20
E	11.80	12.00	12.20
E1	9.90	10.00	10.10
D	11.80	12.00	12.20
D1	9.90	10.00	10.10
e	-	0.80	-
L	0.45	0.60	0.75
L1	-	1.00	-
θ°	0	3.5	7
y	0.0	-	0.08

UNIT: mm

NOTES:

1. JEDEC outline: MS-026-BCB
2. Dimension "D1" and "E1" does not include mold protrusions. Mold protrusions shall not exceed 0.25mm per side.
3. Dimension "b" does not include dambar protrusion. Allowable dambar protrusion shall be 0.08mm total in excess of the "b" dimension at maximum material condition. Dambar cannot be located on the lower radius or the foot. Minimum space between protrusion and an adjacent lead to be 0.07mm.
4. Tolerance: ±0.25mm unless otherwise specified
5. Otherwise dimension follow acceptable spec.

PREPARE	Cynthia	DATE: 2013/1/8
CHECK	Lawrence	DATE: 2013/1/8
APPROVE	Eric	DATE: 2013/1/8

12.3 SOP-28

Small Outline Package

300MIL/SOP-28 PIN

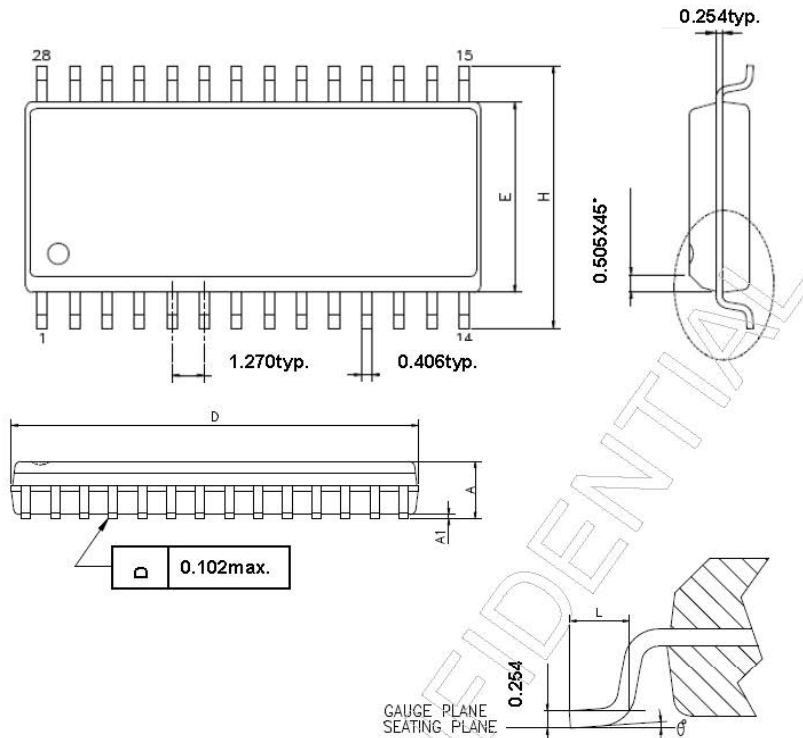

SYMBOLS	MIN	NOR	MAX
A	-	-	2.642
A1	0.102	-	-
D	17.704	18.237	18.390
E	7.391	7.493	7.595
H	10.008	10.312	10.643
L	0.406	0.889	1.270
θ°	0	4	8

UNIT: mm

NOTES:

1. JEDEC outline : MO-119 AB
2. Dimension "D" does not include mold flash, protrusions or gate burrs. Mold flash, protrusions and gate burrs shall not exceed 0.15mm per side.
3. Dimension "E" does not include inter-lead flash, or protrusions. Inter-lead flash and protrusions shall not exceed 0.25mm per side.

PREPARE	Cynthia	DATE: 2013/1/16
CHECK	Lawrence	DATE: 2013/1/16
APPROVE	Eric	DATE: 2013/1/16

13. Development Tools

WT56F108 can work together with Keil C51 development environment. WLINK adaptor can link PC and WT56F108 evaluation board via ICE/ISP driver, and the debugger tools, demo board application software can perform In-Circuit Emulator (ICE) and In-system Programming (ISP) in Windows 98/2000/XP/Win7.

The development kits are illustrated in the figure below:

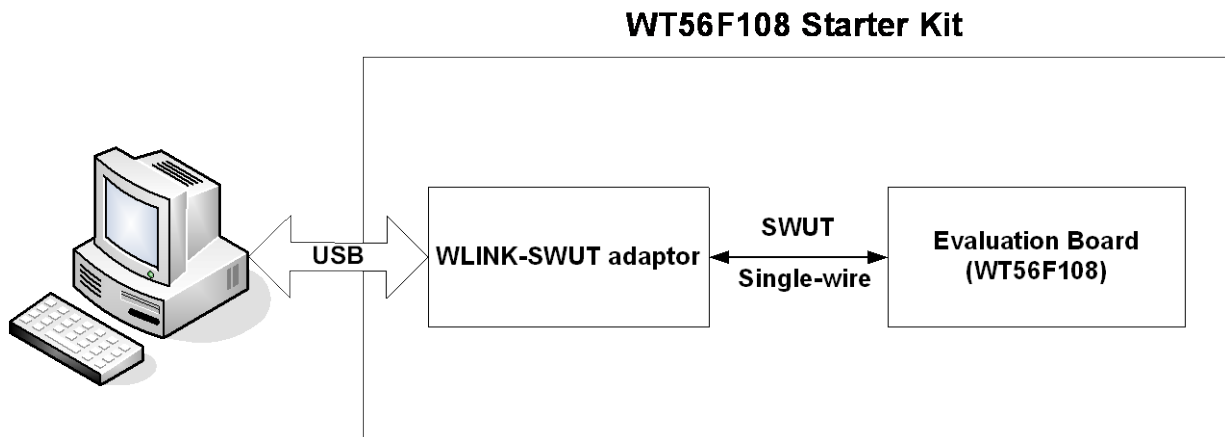

Development Tools List:

Please go to Weltrend' s website <http://www.weltrend.com.tw/> for more information.

Product Information	General Purpose IC	ADC Type MCU	WT51F104 Product Spec
			WT51F116/WT51F108 Product Spec
		ADC+LCD Type MCU	WT56F216 Product Spec
			WT56F108 Product Spec
			WT56F248/WT56F232 Product Spec
Technical Support	Supporting Tools/ General Purpose IC	ICE/ISP	WA001 WLINK-SWUT Adapter
		Mass Production Programming	WA007 WLINK-SWUT-M4S
		Mass Production Programming Daughter Board	WS001 WLINK-SWUT-M4S Daughter Board Support WT56F216/WT56F232/WT56F248MCU RG44AWT LQFP 44 PKG
			WS003 WLINK-SWUT-M4S Daughter Board Support WT56F216 MCU SG28AWT SOP28 PKG
			WS004 WLINK-SWUT-M4S Daughter Board Support WT51F104/WT51F116/WT51F108 MCU OG20AWT SSOP20 PKG
			WS005 WLINK-SWUT-M4S Daughter Board Support WT51F104 MCU SG140WT SOP14 PKG SG080WT SOP8 PKG
			WS006 WLINK-SWUT-M4S Daughter Board Support WT51F104 MCU MG10AWT MSOP10 PKG
			WS007 WLINK-SWUT-M4S Daughter Board Support WT56F108 MCU RG64AWT LQFP64 PKG
			WS009 WLINK-SWUT-M4S Daughter Board Support WT51F116/WT51F108 MCU UG32AWT QFN32 PKG
			WS010 WLINK-SWUT-M4S Daughter Board Support WT51F116/WT51F108 MCU MG10BWT MSOP10 PKG
			WS011 WLINK-SWUT-M4S Daughter Board Support WT56F248/WT56F232 MCU RG64AWT LQFP64 PKG
			WS012 WLINK-SWUT-M4S Daughter Board Support WT56F248/WT56F232 MCU UG32AWT QFN32 PKG
			WS013 WLINK-SWUT-M4S Daughter Board Support WT56F108 MCU RG44AWT LQFP 44 PKG
			WS014 WLINK-SWUT-M4S Daughter Board Support WT56F108 MCU SG28AWT SOP28 PKG

Technical Support	Supporting Tools/ General Purpose IC	Evaluation Board	WB000 WT56F216 EV Board
			WB001 WT51F104 EV Board
			WB005 WT56F216 Starter Kit Board
			WB006 WT51F104 Starter Kit Board
			WB007 WT56F108 Starter Kit Board
			WB008 WT51F116/WT51F108 Starter Kit Board
			WB010 WT56F248/WT56F232 Starter Kit Board
		Starter Kit	WK000 WT56F216 Starter Kit
			WK001 WT51F104 Starter Kit
			WK004 WT56F108 Starter Kit
	WK005 WT51F116/WT51F108 Starter Kit		
	WK007 WT56F248/WT56F232 Starter Kit		
	Technical Data/ General Purpose IC	WLINK Adapter Operation Manual	Doc2 WLINK-SWUT Adapter Installation Manual
			Doc26 WLINK-SWUT-M4S Operation Manual
		ICE/ISP Operation Manual	Doc6 WLINK ICE Operation Manual (uVision IDE Version)
			Doc8 WLINK-SWUT ISP Operation Manual (for Alone Programmer)
		Evaluation Board Operation Manual	Doc12 WT56F216 EV Board Operation Manual
			Doc13 WT51F104 EV Board Operation Manual
			Doc21 WT56F216 Starter Kit Quick Start Guide
			Doc22 WT51F104 Starter Kit Quick Start Guide
Doc23 WT56F216 Starter Kit Operation Manual			
Doc24 WT51F104 Starter Kit Operation Manual			
Doc27 WT56F108 Starter Kit Operation Manual			
Doc28 WT51F116/WT51F108 Starter Kit Operation Manual			
Doc30 WT56F248/WT56F232 Starter Kit Operation Manual			
Mass Production ISP and Supplier Contact Information	Doc20 Mass Production ISP Supplier		

Technical Support	Software Download/ General Purpose IC	WLINK Adapter Driver	SW2 WLINK-SWUT Adapter Driver
		Mass Production Programming Driver	SW2 WLINK-SWUT Adapter Driver
		ICE Driver/ISP Program	SW6 WLINK-SWUT ICE Driver (for uVision IDE)
			SW8 WLINK-SWUT ISP Driver (for uVision IDE)
		ICE Driver/ISP Program	SW9 WLINK-SWUT ISP Program (for Alone Programmer)
			SW17 Auto Install WLINK-SWUT ICE & ISP Driver (for uVision IDE) WLINK-SWUT ISP Driver (for uVision IDE)
		Example Program	SW13 WT56F216 EV Board Example Program
			SW14 WT51F104 EV Board Example Program
			SW18 WT56F216 Starter Kit Board Example Program
			SW19 WT51F104 Starter Kit Board Example Program
			SW21 WT56F108 Starter Kit Board Example Program
			SW22 WT51F116/WT51F108 Starter Kit Board Example Program
			SW25 WT56F248/WT56F232 Starter Kit Board Example Program

14. Revision History

Version	History	Date
1.0	Initial issue	January 2015
1.0	Contents modify	June 2015