

**WT51F108S/104S**  
**3T 8052 Micro-controller**  
**with ADC Function (FLASH)**

**Data Sheet**

**Rev. 1.0**

**June 2016**

**Copyright Notice**

This data sheet is copyrighted by Weltrend Semiconductor, Inc. Do not reproduce, transform to any other format, or send/transmit any part of this documentation without the express written permission of Weltrend Semiconductor, Inc.

**Disclaimers**

**Right to make change –**

This document provides technical information for user. Weltrend Semiconductor, Inc. reserves the right to make change without further notice to any products herein.

## Table of Contents

<b>1. General Description .....</b>	<b>3</b>
<b>2. Features .....</b>	<b>4</b>
<b>3. Block Diagram .....</b>	<b>5</b>
3.1 System Clock Tree.....	6
<b>4. Pin Configuration .....</b>	<b>7</b>
4.1 Pin Description.....	9
4.2 Pin Summary .....	12
4.3 Port Structure.....	14
<b>5. Normal Function.....</b>	<b>19</b>
5.1 CPU .....	19
5.2 RAM.....	19
5.3 Flash Memory .....	21
5.4 Memory Mapping.....	22
5.5 In-System Programming (ISP) (Important!!! Must Read!!!) .....	26
5.6 Timer/Counter .....	29
5.7 Reset .....	32
5.8 System Clock and Clock sources.....	34
<b>6. Enhanced Function .....</b>	<b>36</b>
6.1 External Special Function Register (XFR).....	36
6.2 I/O Port .....	40
6.3 Interrupt .....	52
6.4 Universal Asynchronous Receiver-Transmitter (UART) .....	63
6.5 External Interrupt Request (IRQ).....	68
6.6 Pulse Width Modulation (PWM).....	71
6.7 Power Management .....	77
6.8 12 MHz/24 MHz RC Oscillator Calibration .....	90
6.9 Watchdog Timer and Watch Timer .....	94
6.10 I <sup>2</sup> C Serial Interface.....	98
6.11 Enhanced Timer/Counter.....	102
6.12 Analog/Digital Converter (ADC).....	107
6.13 Low Voltage Reset (LVR).....	113
6.14 Low Voltage Detection (LVD).....	114
6.15 Low Voltage Detection Reset (LVDR).....	115
6.16 Emulated E <sup>2</sup> PROM .....	117
6.17 Code Option.....	121
6.18 Read Out Protection .....	131
6.19 Internal Voltage Reference Source (BandGap).....	132

<b>7. Electrical Characteristics</b> .....	<b>133</b>
7.1 Absolute Maximum Ratings.....	133
7.2 Recommended Operating Parameters.....	133
7.3 DC Electrical Characteristics ( $V_{DD} = 1.8V \sim 5V, -40^{\circ}C \sim +105^{\circ}C$ ).....	134
7.4 AC Electrical Characteristics ( $T_A = 25^{\circ}C$ ).....	136
7.5 Internal RC Oscillator Temperature Tolerance table.....	137
7.6 A/D Converting Characteristics ( $T_A = 25^{\circ}C$ ).....	138
7.7 Bandgap Electrical Characteristic.....	139
7.8 Low Voltage Reset (LVR), Low Voltage Detection (LVD) & Low Voltage Detection Reset (LVDR) Electrical Characteristics ( $T_A = 25^{\circ}C$ ).....	140
7.9 Thermal Resistance Notice.....	140
<b>8. Application Circuits</b> .....	<b>141</b>
8.1 Power Supply.....	141
8.2 Oscillator Circuits.....	142
8.3 RESET Circuit.....	144
8.4 Standard Circuit.....	145
8.5 Development board circuits.....	146
<b>9. Product Naming Rule</b> .....	<b>147</b>
<b>10. Ordering Information</b> .....	<b>147</b>
<b>11. Pad Diagram &amp; Location Table</b> .....	<b>148</b>
<b>12. Package Dimension</b> .....	<b>150</b>
12.1 32-Pin QFN.....	150
12.2 20-Pin SSOP.....	151
12.3 16-Pin SOP.....	152
12.4 10-Pin MSOP.....	153
<b>13. Development Tools</b> .....	<b>154</b>
<b>14. Revision History</b> .....	<b>158</b>

## 1. General Description

The WT51F108S/104S is a general-purpose single chip Microcontroller provided by Weltrend, a well-known IC Design House in Taiwan. In addition to using the advanced 3T 8052 single-chip core, wide and low operating voltage range (1.8V ~ 5.5V), and high noise immunity, the product consists of 8Kx8 (4Kx8 for WT51F104S) Flash Program Memory, 512x8 RAM, abundant peripheral resources and versatile power management (refer to the content for more details).

The above features make the WT51F108S/104S suitable for a wide range of applications, especially in areas such as home appliances, cooling fan, electronic ballast, car alarm, ultrasonic parking assistant sensors, and so on. The WT51F108S/104S is a low cost high performance product with kinds of package to replace the mainstream products on the market (refer to "WT51F108S/104S Application Notes" for more details). In order to contribute more competitive ability, Weltrend also provides wafer and dice sale for the customer.

Part No.	Core	PROM (Byte)	SRAM (Byte)	Timer	I/O (Max)	PWM (BitxCh)	Interface	ADC (BitxCh)	LDO18 Capacitor	PKG Type
WT51F104	1T-8052	4K	256	2	18	16-bitx2	M/S I <sup>2</sup> C x 1 UART x 1 SPI x 1	10-bitx16	X	8SOP 10MSOP 14SOP 20SSOP
WT51F104S	3T-8052	4K	256	1	29	16-bitx2	Slave I <sup>2</sup> C x 1 UART x 1	10-bitx16	need	10MSOP 16SOP 20SSOP 32QFN
WT51F108	1T-8052	8K	512	3	30	16-bitx4	M/S I <sup>2</sup> C x 1 UART x 1 SPI x 1	10-bitx16	X	10MSOP 20SSOP 32QFN
WT51F108S	3T-8052	8K	512	1	29	16-bitx2	Slave I <sup>2</sup> C x 1 UART x 1	10-bitx16	need	10MSOP 16SOP 20SSOP 32QFN
WT51F116	1T-8052	16K	512	3	30	16-bitx4	M/S I <sup>2</sup> C x 1 UART x 1 SPI x 1	10-bitx16	X	10MSOP 20SSOP 32QFN

## 2. Features

WT51F108S/104S is an advanced 8052 Micro-controller, and it also provides the following features.

- 3T 8052 core, MCS-51 instruction set compatible
- Instruction execution time: Min. = 125ns @24 MHz
- 512/256 Bytes of RAM (256 Bytes of standard 8052 internal Data RAM + 256 Bytes of external RAM (only available for WT51F108S))
- 8K Bytes of flash memory for program storage (4K Bytes for WT51F104S)
- Supporting Internal & External Clock Oscillators:
  - ◆ Internal clock: 12 MHz/24 MHz RC oscillator or 32 kHz RC oscillator
  - ◆ External clock: 32.768 kHz ~ 24 MHz Crystal Oscillator
- Dual 16-bit Data Pointers (DPTR0 & DPTR1)
- One 16-bit Timer/Counters (Timer0)
- One Watchdog Timer (WDT)
- One Watch Timer
- One 16-bit Enhanced Timer with Capture function
- One UART (UART0), supports baud rate 1200 bps ~ 230400 bps (at 12 MHz)
- Emulated E<sup>2</sup>PROM
- One slave I<sup>2</sup>C interface
- Two 16-bit PWMs (PWM0 & PWM1) with several (up to four) outputs
- 16-channel 10-bit Analog/Digital Converter (ADC0 ~ ADC15) with Voltage Reference Source (Band-Gap)
- Three power-saving modes: Sleep mode, Green mode and Idle mode
- 8 external Interrupt IRQ pins (IRQ0 ~ IRQ7)
- 29 programmable bi-directional I/O pins, 7 of them with both high current sink/source ability (20 mA)
- Low Voltage Detection (LVD) and Low Voltage Detection Reset (LVDR), both of them are programmable
- On-chip Power On Reset (POR) and Low Voltage Reset (LVR)
- Built-in single-wire In-Circuit Emulator (ICE) and In-System Program (ISP)
- Read Out Protection
- Operating voltage range: 1.8V ~ 5.5V
- Operating temperature: -40°C ~ +105°C
- Package (Green Package): MSOP10 (118 mil), SOP16 (150 mil), SSOP20 (150 mil), QFN32 (5mm x 5mm)

### 3. Block Diagram

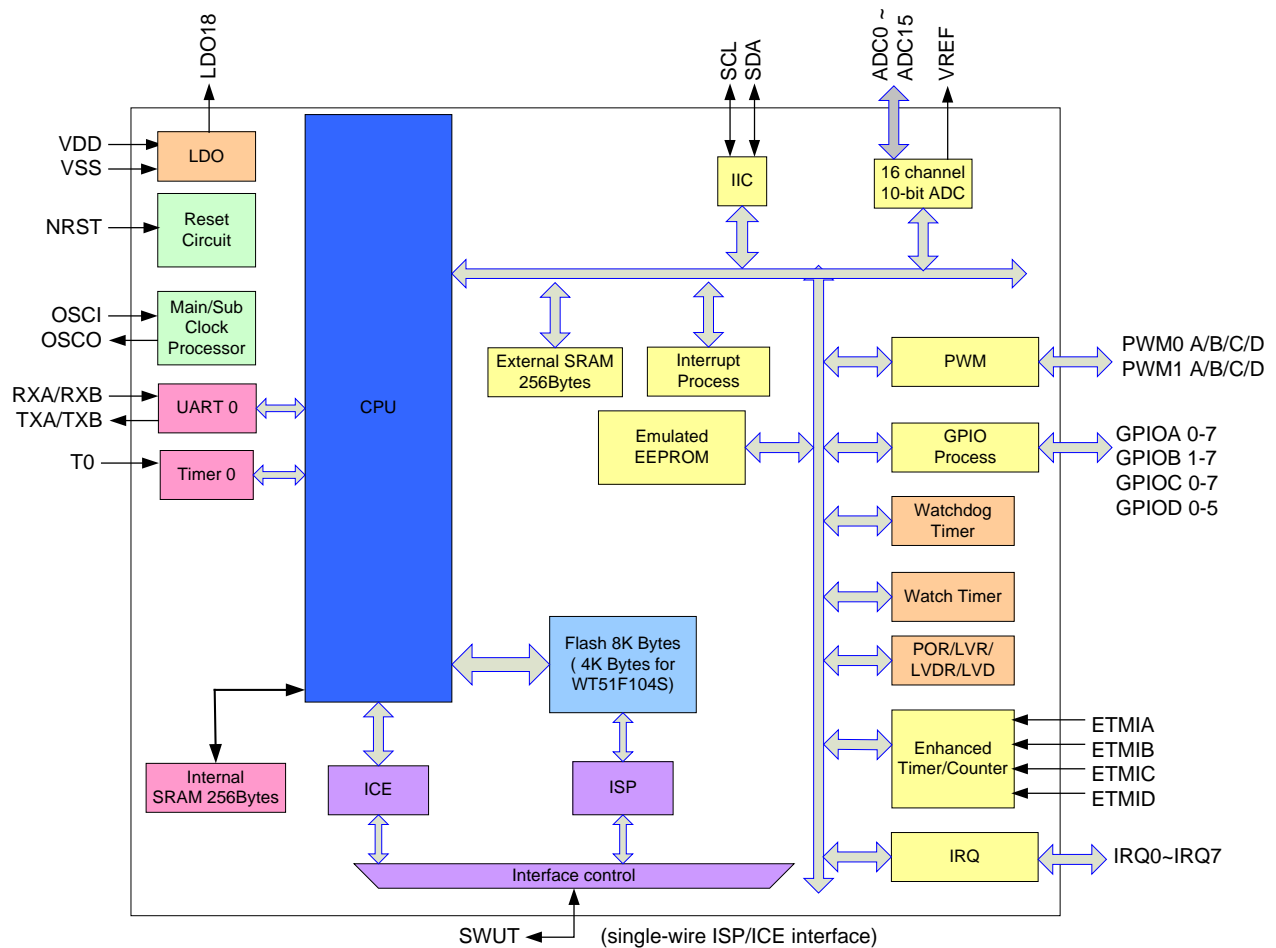

### 3.1 System Clock Tree

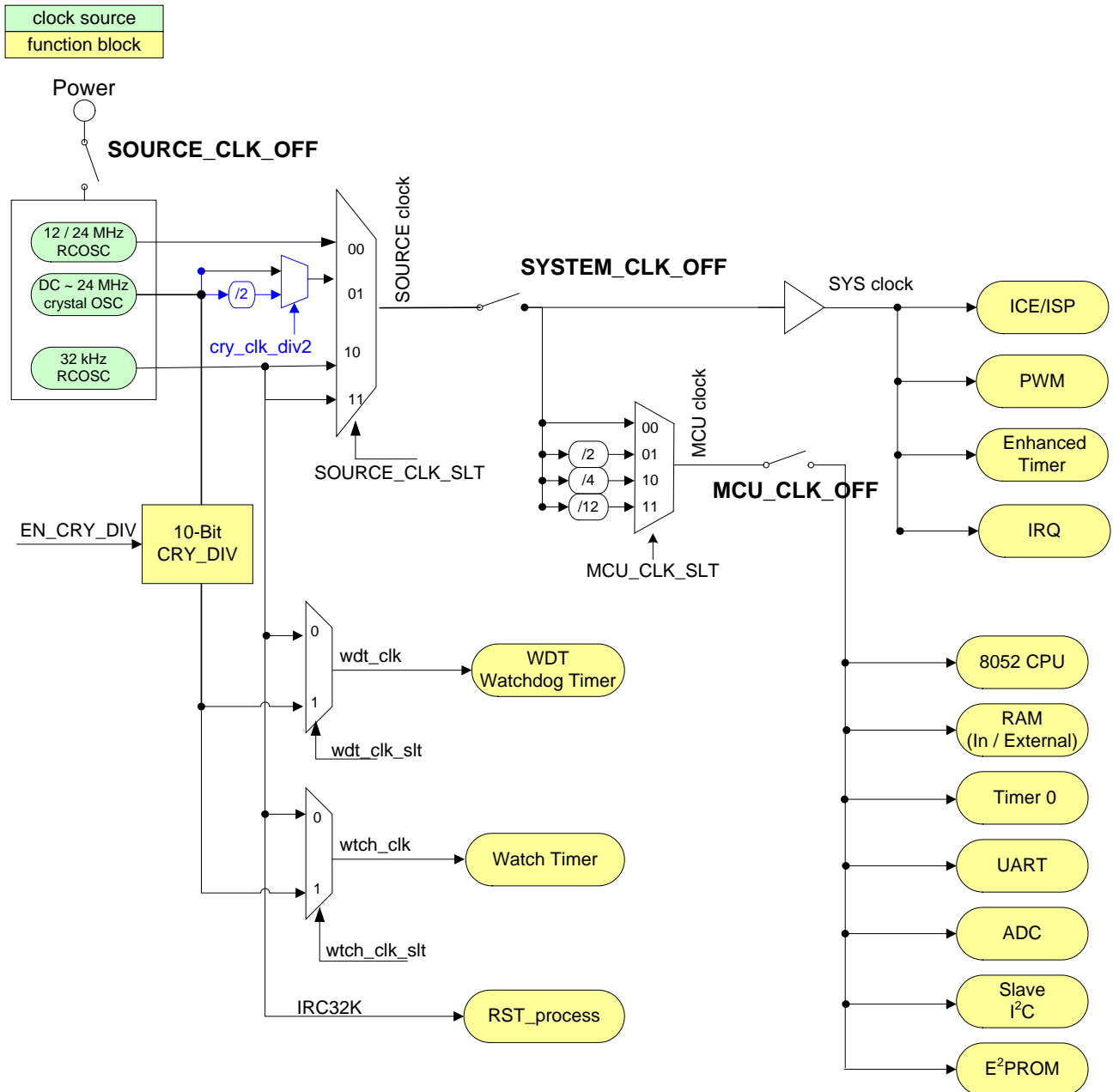

\* When using the external Crystal Oscillator, please select the corresponding driving ability according to its frequency. Refer to Oscillator Driver Control Register (XFR: 0x08) CRY\_12M\_DR[1:0] bit for more details.

## 4. Pin Configuration

### WT51F108S-UG32AWT 32-Pin QFN (WT51F104S is the same)

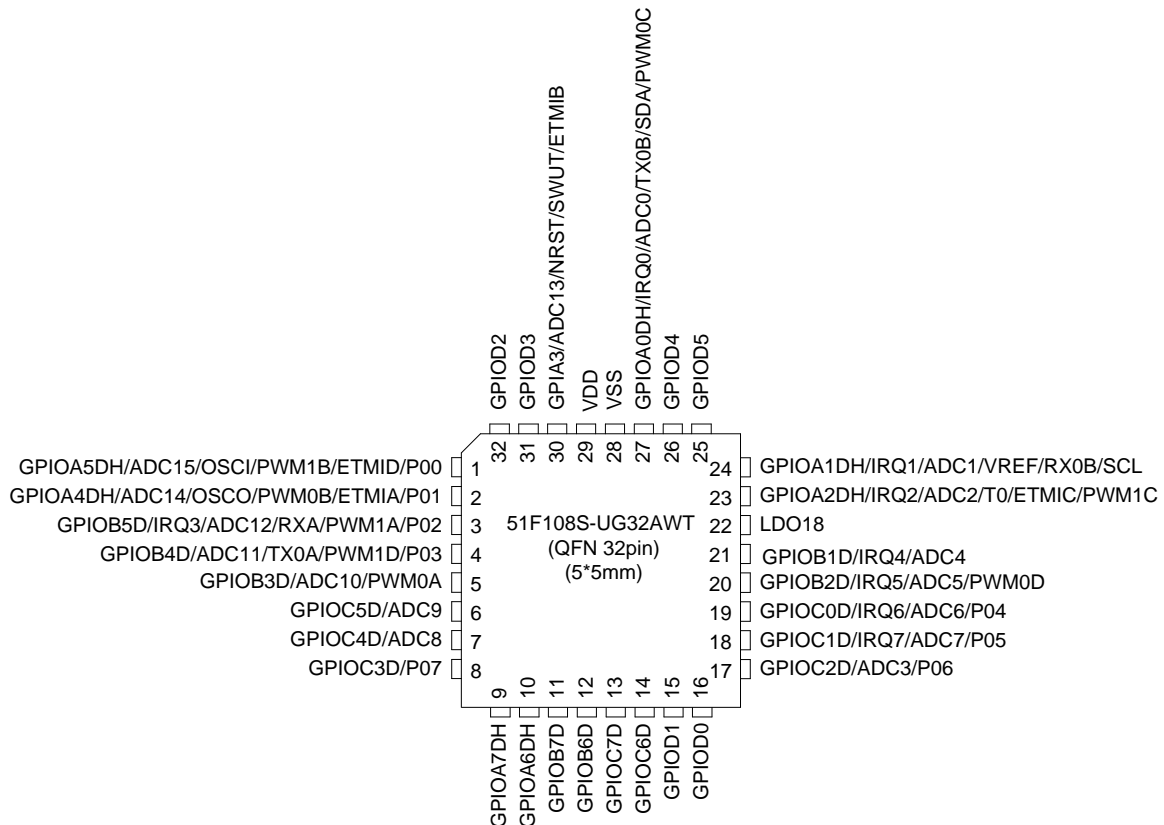

### WT51F108S-OG20AWT 20-Pin SSOP (WT51F104S is the same)

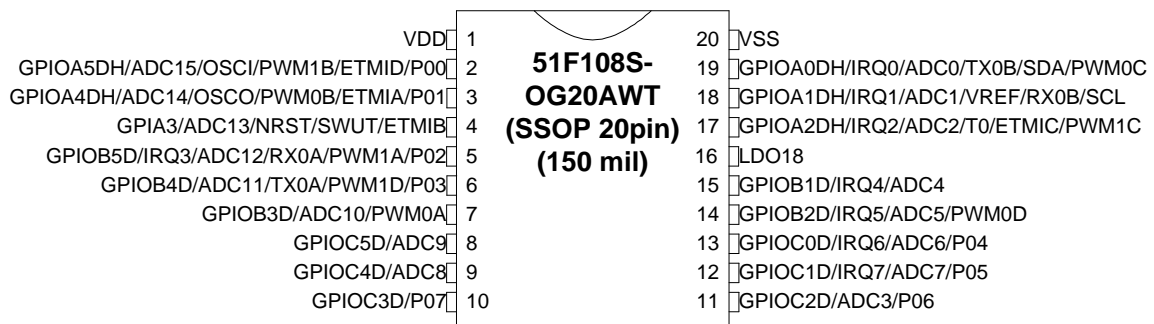



**WT51F108S-SG16AWT 16-Pin SOP (WT51F104S is the same)**

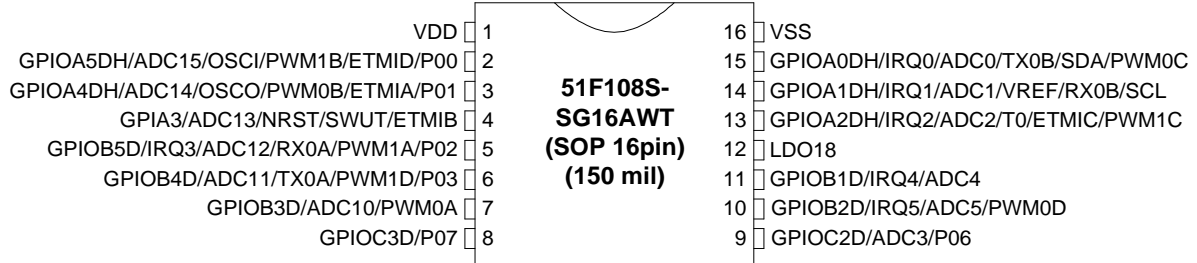

**WT51F108S-MG10BWT 10-Pin MSOP (WT51F104S is the same)**

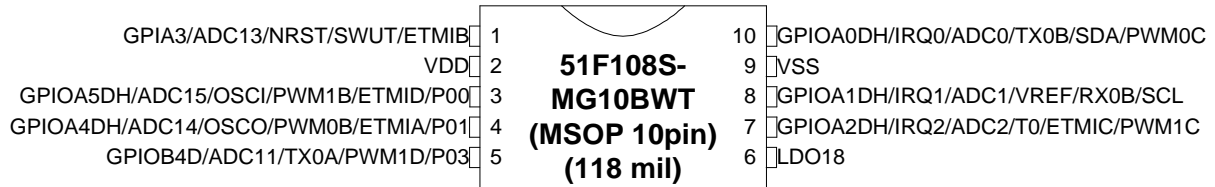

## 4.1 Pin Description

Pin Number				Pin Name	Primary Functions		
UG32A WT	OG20A WT	SG16A WT	MG10B WT		I/O	Descriptions	Circuit Type
29	1	1	2	VDD	PWR	VDD power: add external 4.7uF+ 0.1uF	
1	2	2	3	GPIOA5DH/ ADC15/ OSCI/ PWM1B/ ETMID/ P00	I/O	GPIOA5DH: General-purpose I/O with programmable high current sink/source push-pull or open drain ADC15: Analog/Digital Converter Input 15 OSCI: External Oscillator Input PWM1B: PWM1 Output pin of Path B ETMID: Enhanced Timer/Counter Clock Source or Capture Input of Path D P00: Mapping to 8052 P0.0 (Notes 2)	B
2	3	3	4	GPIOA4DH/ ADC14/ OSCO/ PWM0B/ ETMIA/ P01	I/O	GPIOA4DH: General-purpose I/O with programmable high current sink/source push-pull or open drain ADC14: Analog/Digital Converter Input 14 OSCO: Output of External Oscillator PWM0B: PWM0 Output pin of Path B ETMIA: Enhanced Timer/Counter Clock Source or Capture Input of Path A P01: Mapping to 8052 P0.1 (Notes 2)	B
30	4	4	1	GPIA3/ ADC13/ NRST/ SWUT/ ETMIB	I	GPIA3D: Input pin ADC13: Analog/Digital Converter Input 13 NRST: Reset pin SWUT: Single-wire ISP/ICE interface ETMIB: Enhanced Timer/Counter Clock Source or Capture Input of Path B	D
3	5	5		GPIOB5D/ IRQ3 ADC12/ RX0A/ PWM1A/ P02	I/O	GPIOB5D: General-purpose I/O with programmable push-pull or open drain IRQ3: External Interrupt Request 3 ADC12: Analog/Digital Converter Input 12 RX0A: UART0 Data input of Path A (Notes 2) PWM1A: PWM1 Output pin of Path A P02: Mapping to 8052 P0.2 (Notes 2)	C1
4	6	6	5	GPIOB4D/ ADC11/ TX0A/ PWM1D/ P03	I/O	GPIOB4D: General-purpose I/O with programmable push-pull or open drain ADC11: Analog/Digital Converter Input 11 TX0A: UART0 Data output of Path A (Notes 2) PWM1D: PWM1 Output pin of Path D P03: Mapping to 8052 P0.3 (Notes 2)	C1
5	7	7		GPIOB3D/ ADC10/ PWM0A	I/O	GPIOB3D: General-purpose I/O with programmable push-pull or open drain ADC10: Analog/Digital Converter Input 10 PWM0A: PWM0 Output pin of Path A	C1

Pin Number				Pin Name		Primary Functions	
UG32A WT	OG20A WT	SG16A WT	MG10B WT		I/O	Descriptions	Circuit Type
6	8			GPIOC5D/ ADC9	I/O	GPIOC5D: General-purpose I/O with programmable push-pull or open drain ADC9: Analog/Digital Converter Input 9	C1
7	9			GPIOC4D/ ADC8	I/O	GPIOC4D: General-purpose I/O with programmable push-pull or open drain ADC8: Analog/Digital Converter Input 8	C1
8	10	8		GPIOC3D/ P07	I/O	GPIOC3D: General-purpose I/O with programmable push-pull or open drain P07: Mapping to 8052 P0.7 (Notes 2)	A2
9				GPIOA7DH	I/O	GPIOA7DH: General-purpose I/O with programmable high current sink/source push-pull or open drain	A
10				GPIOA6DH	I/O	GPIOA6DH: General-purpose I/O with programmable high current sink/source push-pull or open drain	A
11				GPIOB7D	I/O	GPIOB7D: General-purpose I/O with programmable push-pull or open drain	A
12				GPIOB6D	I/O	GPIOB6D: General-purpose I/O with programmable push-pull or open drain	A
13				GPIOC7D	I/O	GPIOC7D: General-purpose I/O with programmable push-pull or open drain	A
14				GPIOC6D	I/O	GPIOC6D: General-purpose I/O with programmable push-pull or open drain	A
15				GPIOD1	I/O	GPIOD1: General-purpose I/O with push-pull	A1
16				GPIOD0	I/O	GPIOD0: General-purpose I/O with push-pull	A1
17	11	9		GPIOC2D/ ADC3/ P06	I/O	GPIOC2D: General-purpose I/O with programmable push-pull or open drain ADC3: Analog/Digital Converter Input 3 P06: Mapping to 8052 P0.6 (Notes 2)	A2
18	12			GPIOC1D/ IRQ7/ ADC7/ P05	I/O	GPIOC1D: General-purpose I/O with programmable push-pull or open drain IRQ7: External Interrupt Request 7 ADC7: Analog/Digital Converter Input 7 P05: Mapping to 8052 P0.5 (Notes 2)	C1
19	13			GPIOC0D/ IRQ6/ ADC6/ P04	I/O	GPIOC0D: General-purpose I/O with programmable push-pull or open drain IRQ6: External Interrupt Request 6 ADC6: Analog/Digital Converter Input 6 P04: Mapping to 8052 P0.4 (Notes 2)	C1
20	14	10		GPIOB2D/ IRQ5/ ADC5/ PWM0D	I/O	GPIOB2D: General-purpose I/O with programmable push-pull or open drain IRQ5: External Interrupt Request 5 ADC5: Analog/Digital Converter Input 5 PWM0D: PWM0 output pin of Path D	C1

Pin Number				Pin Name		Primary Functions	
UG32A WT	OG20A WT	SG16A WT	MG10B WT		I/O	Descriptions	Circuit Type
21	15	11		GPIOB1D/ IRQ4/ ADC4	I/O	GPIOB1D: General-purpose I/O with programmable push-pull or open drain IRQ4: External Interrupt Request 4 ADC4: Analog/Digital Converter Input 4	C1
22	16	12	6	LDO18	PWR	LDO18: add external 4.7uF+ 0.1uF	C1
23	17	13	7	GPIOA2DH/ IRQ2/ ADC2/ T0/ ETMIC/ PWM1C	I/O	GPIOA2DH: General-purpose I/O with programmable high current sink/source push-pull or open drain IRQ2: External Interrupt Request 2 ADC2: Analog/Digital Converter Input 2 T0: External Input pin of Counter 0 ETMIC: Enhanced Timer/Counter Clock Source or Capture Input of Path C PWM1C: PWM1 output pin of Path C	C1
24	18	14	8	GPIOA1DH/ IRQ1/ ADC1/ VREF/ RX0B/ SCL	I/O	GPIOA1DH: General-purpose I/O with programmable high current sink/source push-pull or open drain IRQ1: External Interrupt Request 1 ADC1: Analog/Digital Converter Input 1 VREF: Analog/Digital Converter Voltage Reference input pin RX0B: UART0 Data input of Path B (Notes 2) SCL: SCL pin of I <sup>2</sup> C	C2
25				GPIOD5	I/O	GPIOD5: General-purpose I/O with push-pull	A1
26				GPIOD4	I/O	GPIOD4: General-purpose I/O with push-pull	A1
27	19	15	10	GPIOA0DH/ IRQ0/ ADC0/ TX0B/ SDA/ PWM0C	I/O	GPIOA0DH: General-purpose I/O with programmable high current sink/source push-pull or open drain IRQ0: External Interrupt Request 0 ADC0: Analog/Digital Converter Input 0 TX0B: UART0 Data Output of Path B (Notes 2) SDA: SDA pin of I <sup>2</sup> C PWM0C: PWM0 output pin of Path C	C2
28	20	16	9	VSS	GND	Core ground	
31				GPIOD3	I/O	GPIOD3: General-purpose I/O with push-pull	A1
32				GPIOD2	I/O	GPIOD2: General-purpose I/O with push-pull	A1

**Notes 1: All I/O pins are floating on Reset status.**

**Notes 2: While using 8052 port (P0.x) or UART, please set the mapping GPIOx\_TYP as open drain, and add external pull-high resistor.**

## 4.2 Pin Summary

Explain each pin function in details.

Pin Name	Type	Description
<b>PORT</b>		
GPIOA0 ~ GPIOA7	I/O	8-bit bidirectional general-purpose I/O port (GPIA3 is input only pin)
GPIOB1 ~ GPIOB7	I/O	7-bit bidirectional general-purpose I/O port
GPIOC0 ~ GPIOC7	I/O	8-bit bidirectional general-purpose I/O port
GPIOD0 ~ GPIOD5	I/O	6-bit bidirectional general-purpose I/O port
<b>Timer 0</b>		
T0	I	Timer/Counter 0 External Input
<b>Enhanced Timer/Counter</b>		
ETMIA	I	Enhanced Timer/Counter Clock Source or Capture Input (Path A)
ETMIB	I	Enhanced Timer/Counter Clock Source or Capture Input (Path B)
ETMIC	I	Enhanced Timer/Counter Clock Source or Capture Input (Path C)
ETMID	I	Enhanced Timer/Counter Clock Source or Capture Input (Path D)
<b>IRQ</b>		
IRQ0 ~ IRQ7	I	8 External Interrupt Request Input pins
<b>PWM</b>		
PWM0 A/B/C/D	O	PWM 0 Output of Path A / Path B / Path C / Path D
PWM1 A/B/C/D	O	PWM 1 Output of Path A / Path B / Path C / Path D
<b>UART</b>		
RX0 A/B	I	UART0 Receive Path A or Path B <b>(Note)</b>
TX0 A/B	O	UART0 Transmit Path A or Path B <b>(Note)</b>
<b>ADC</b>		
ADC0 ~ ADC15	I	16 Analog/Digital Input pins
<b>I<sup>2</sup>C</b>		
SCL	I/O	I <sup>2</sup> C interface clock
SDA	I/O	I <sup>2</sup> C interface data
<b>VCC &amp; VSS</b>		
VDD	P	Power: add external 4.7uF + 0.1uF
VSS	P	Ground
OSCO	O	Main (Sub) oscillator output
OSCI	I	Main (Sub) oscillator input

Pin Name	Type	Description
NRST	I	CPU reset
LDO18	P	LDO18: add external 4.7uF + 0.1uF
<b>ISP &amp; ICE</b>		
SWUT	I/O	Single-wire ISP & ICE interface

**Note: While using 8052 port (P0.x) or UART, please set the mapping GPIOx\_TYP as open drain, and add external pull-high resistor.**

### 4.3 Port Structure

#### I/O Structure (Type A)

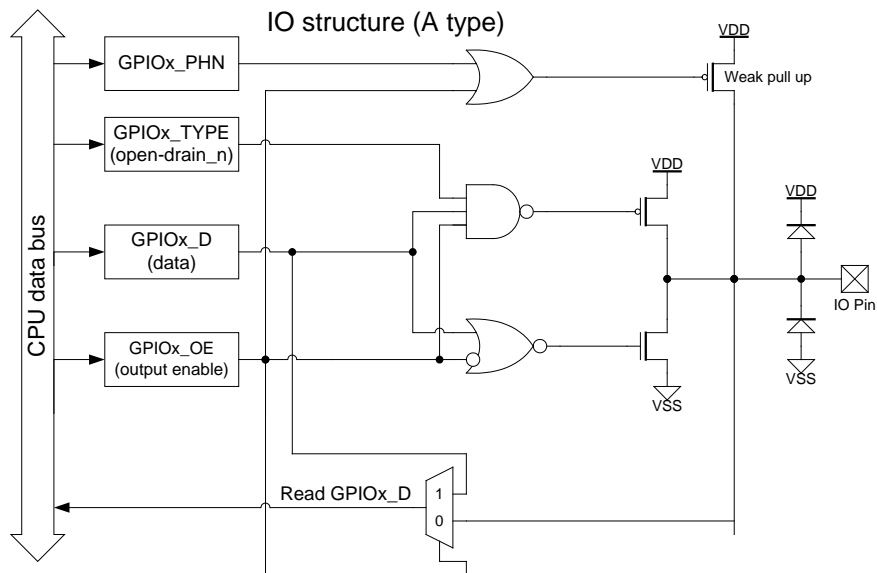

#### I/O Structure (Type A1)

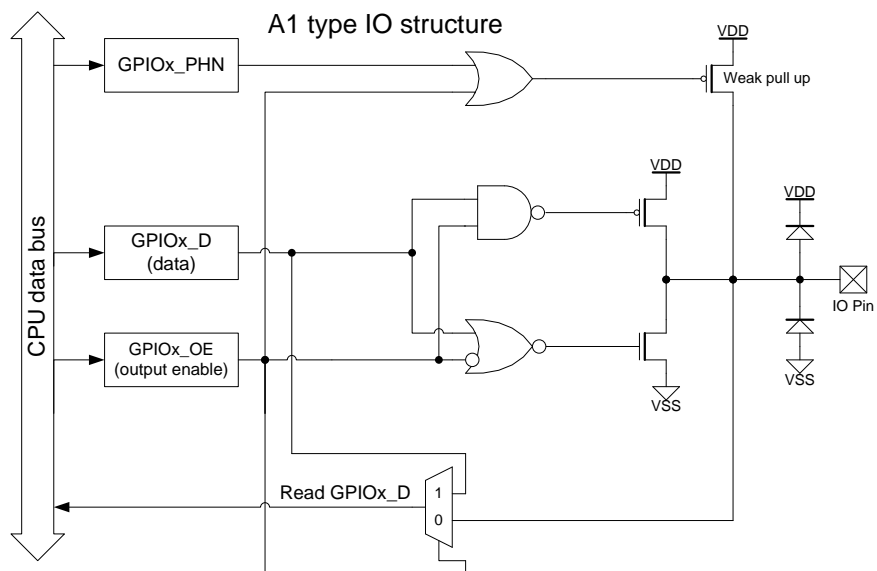

**I/O Structure (Type A2)**

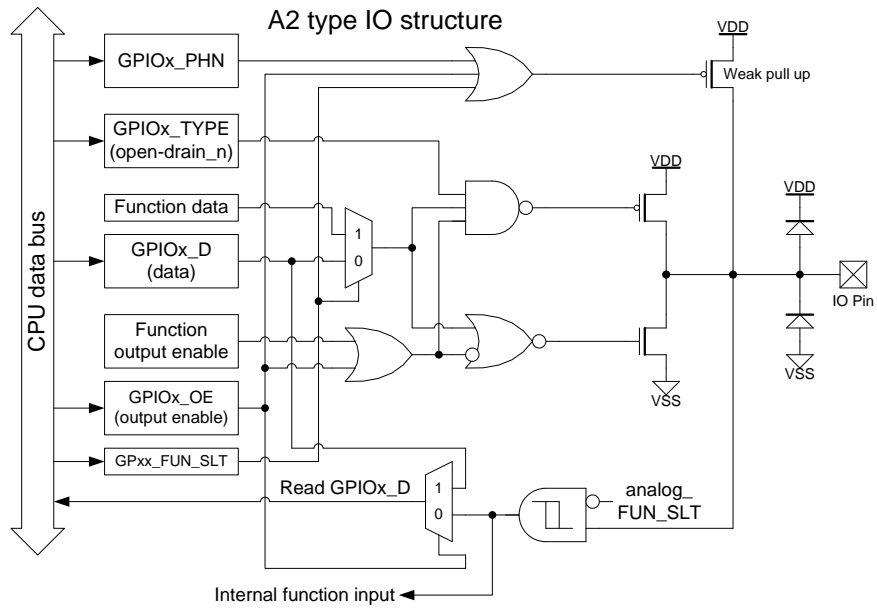



**I/O Structure (Type B)**

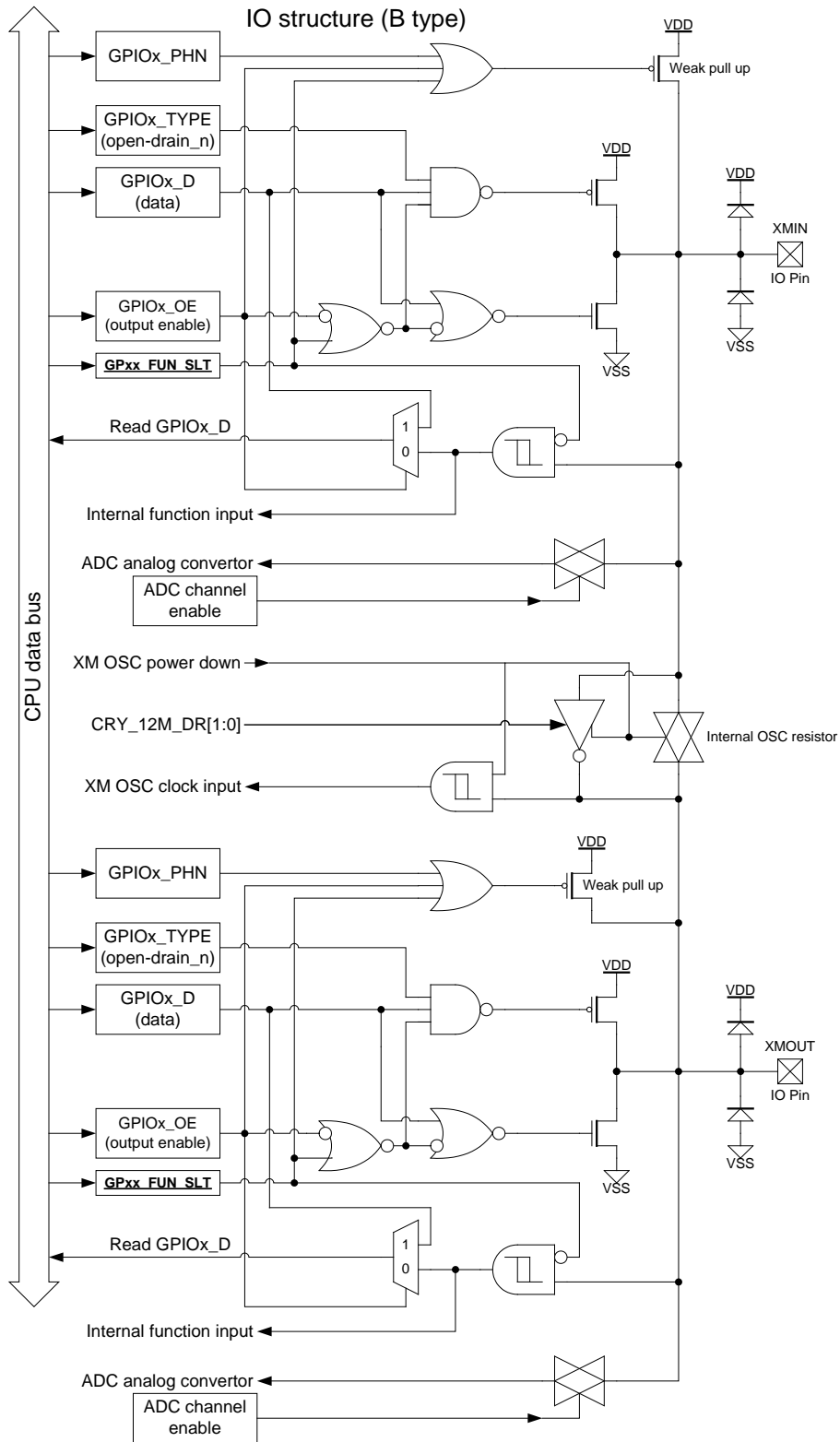

**I/O Structure (Type C1)**

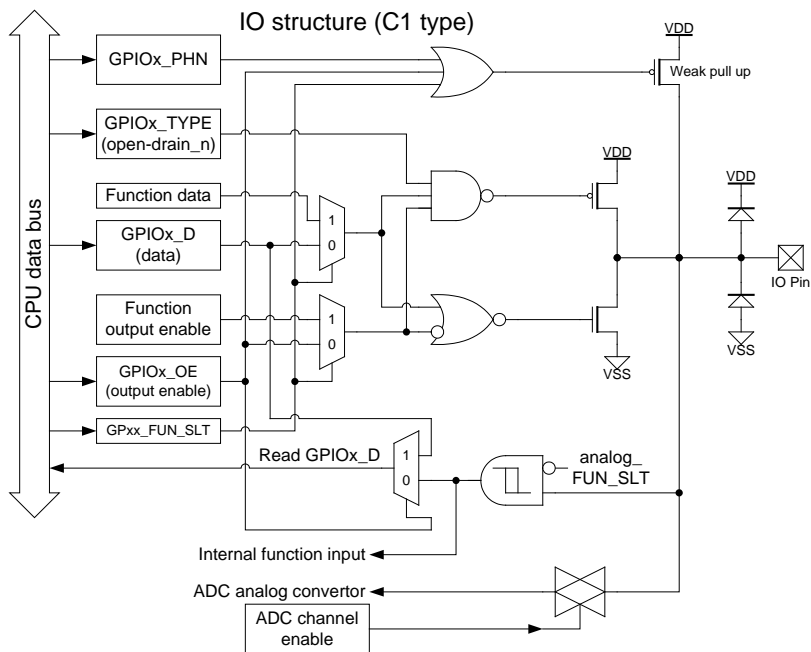

**I/O Structure (Type C2)**

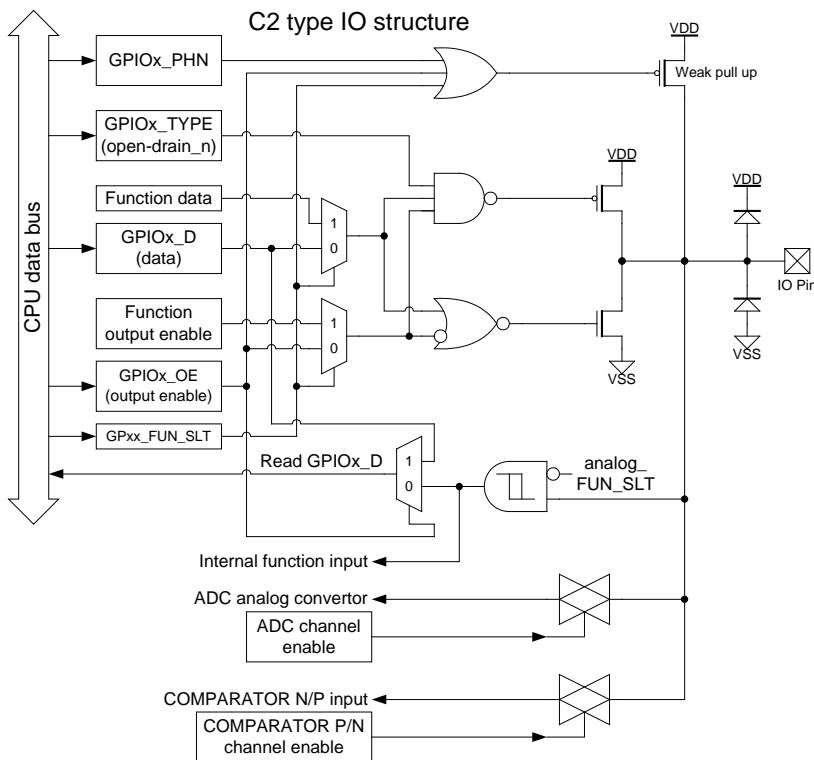

**I/O Structure (Type D)**

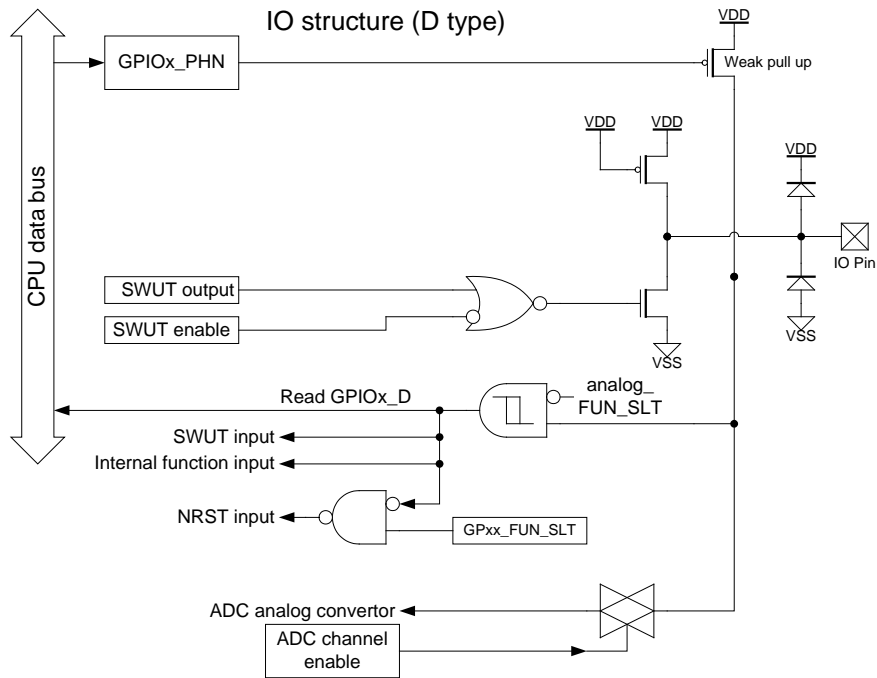

## 5. Normal Function

### 5.1 CPU

The WT51F108S/104S has an embedded 8-bit 3T 8052 compatible CPU with 16-bit space addressable and 8-bit data access functions. The instruction execution time of 3T 8052 is four times faster than that of the conventional 12T 8052. All of the functions and Special Function Register (SFR) definitions will be described in below sections.

### 5.2 RAM

The WT51F108S consists of 512 Bytes of RAM (256 Bytes of the general 8052 internal RAM + 256 Bytes of the external RAM).

The WT51F104S consists of 256 Bytes of RAM (256 Bytes of the general 8052 internal RAM).

Below figure shows a map of the RAM. For Peripheral Control Registers, see section 6.1.

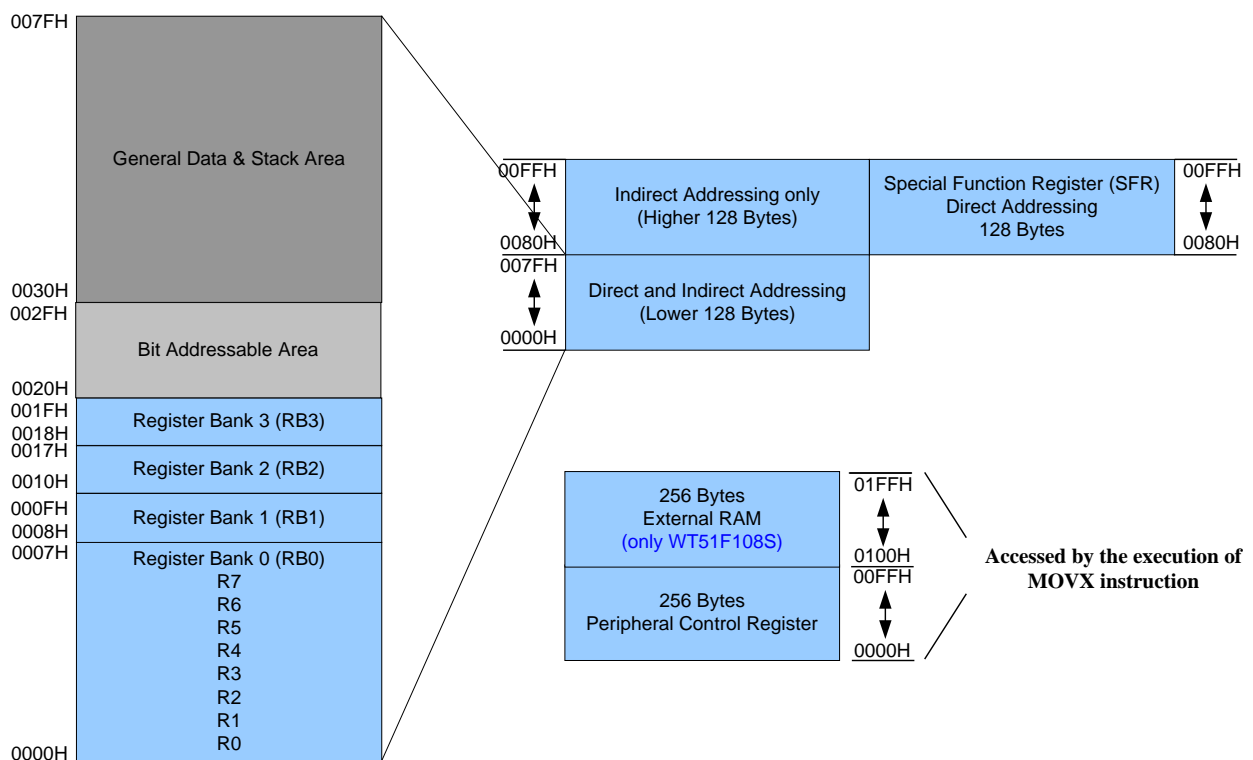

The internal SRAM contains:

128 Bytes of internal SRAM, locates from 0x0000H to 0x007FH (direct and indirect addressing is allowed)

128 Bytes of internal SRAM, locates from 0x0080H to 0x00FFH (indirect addressing)

256 Bytes of external SRAM, locates from 0x0100H to 0x01FFH (accessed by MOVX)

Its main purpose is for storing data in the program, and therefore it is also called Data Memory. The Data memory of WT51F108S/104S includes the following sections:

- (1) The lower 128 bytes of internal SRAM (0000H ~ 007FH) which can be accessed by direct or indirect addressing are divided into 3 segments:

**General Purpose Register:** Locates from 0000H to 001FH, 32 Bytes in total, can be divided into 4 register banks. Each register bank contains 8 general purpose registers (R0~R7). 4 register banks can be selected by the select bit RS1 and RS0 in the Program Status Word Register.

**Bit Addressable Area:** Locates from 20H to 2FH, 16 Bytes in total. Each one of the 128 bits of this segment can be directly addressed by Bit Addressing.

**General Data Area:** Locates from 0030H to 007FH, 80 Bytes are available to the user as data RAM (including the Stack area).

- (2) The higher 128 bytes of internal SRAM (0080H ~ 00FFH) can be accessed by indirect addressing through R0 or R1 (\*).
- (3) Special Function Registers (SFR), locates from 0080H to 00FFH, can be accessed by direct addressing (\*).
- (4) 256 Bytes of external SRAM, locates from 0x0100H to 0x01FFH, can be accessed by MOVX (indirect addressing).
- (\*) Although the SFR and the higher 128 Bytes of internal SRAM occupy the same addresses (0080H ~ 00FFH), they are two separate areas. MCU will automatically determine which area is in use by two different accessing ways.

### 5.3 Flash Memory

The WT51F108S/104S consists of embedded 8K/4K flash, which can be served as general Program memory or Emulated E<sup>2</sup>PROM with features as below:

- ◆ FLASH memory: 8K/4K Bytes
- ◆ Operating voltage: 1.8V ~ 5.5V
- ◆ In-System Programming (ISP)
- ◆ Over 10 years Data Retention
- ◆ Read Out Protection
- ◆ Emulated E<sup>2</sup>PROM function

WT51F108S Flash Memory

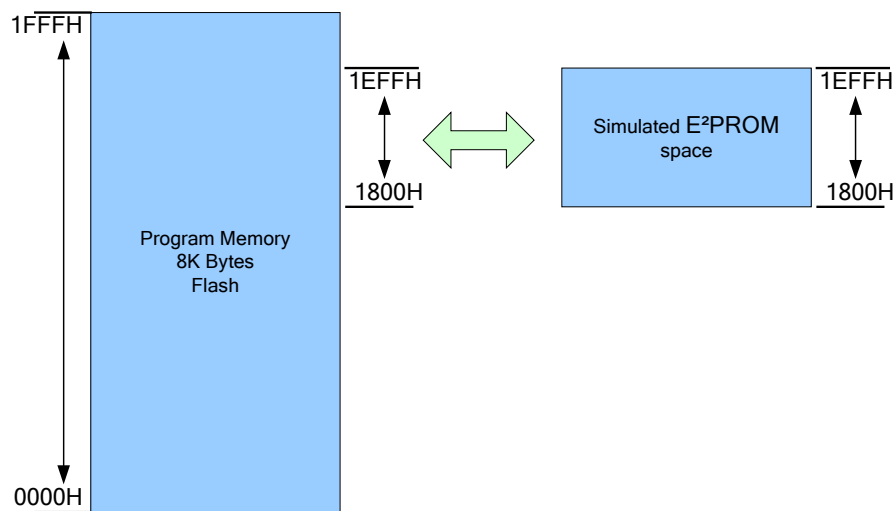

WT51F104S Flash Memory

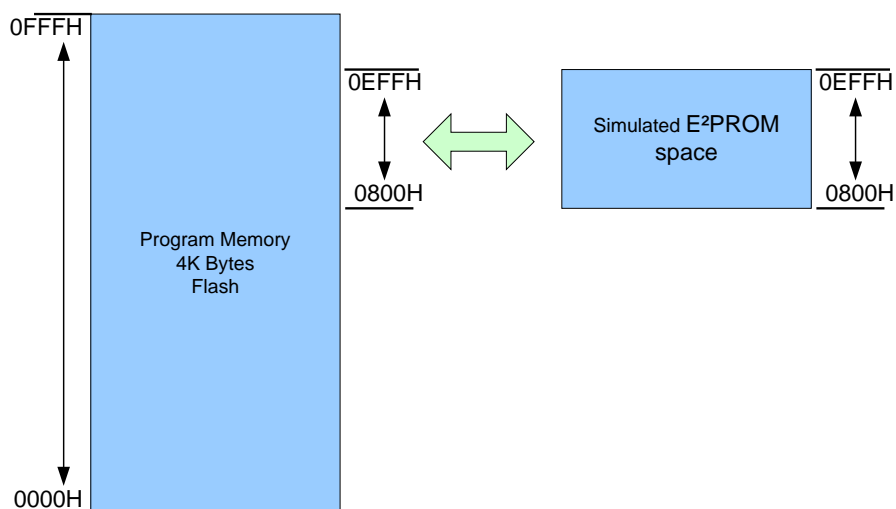

## 5.4 Memory Mapping

WT51F108S/104S built-in 128 bytes of direct addressing register, with the standard Special Function Register (SFR) as described below.

- CPU Core Register: ACC, B, PSW, SP, DPL0, DPH0, DPL1, DPH1
- Interrupt Register: IP, IE, XICON
- I/O Port Register: P0
- Timer Register: TCON, TMOD, TL0, TH0
- UART0 Register: SCON0, SBUF0, SBRG0H, SBRG0L, PCON

### Special Function Register (SFR) MAP:

	Bit Addressable	No Bit Addressable						
F8H								FFH
F0H	B							F7H
E8H								EFH
E0H	ACC							E7H
D8H								DFH
D0H	PSW							D7H
C8H								CFH
C0H	XICON							C7H
B8H	IP							BFH
B0H								B7H
A8H	IE							AFH
A0H								A7H
98H	SCON0	SBUF0	SBRG0H	SBRG0L				9FH
90H								97H
88H	TCON	TMOD	TL0		TH0		CKCON	8FH
80H	P0	SP	DPL0	DPH0			PCON	87H

### Special Function Register (SFR) Table:

Register Name	Address	Reset Value	Description
P0	80H	FFH	Port-0
SP	81H	07h	Stack Pointer
DPL0	82H	00h	Data Pointer 0 low byte
DPH0	83H	00h	Data Pointer 0 high byte
PCON	87H	00h	Power Control Register
TCON	88H	00h	Timer 0/1 Counter Control
TMOD	89H	00h	Timer 0/1 Mode Control
TL0	8AH	00h	Timer 0, low byte

Register Name	Address	Reset Value	Description
TH0	8CH	00h	Timer 0, high byte
CKCON	8EH	00h	Timer clock-base select
SCON0	98H	00h	Serial Port 0, Control Register
SBUF0	99H	00h	Serial Port 0, Data Buffer
SBRG0H	9AH	00h	Serial Baud rate Generator, high byte
SBRG0L	9BH	00h	Serial Baud rate Generator, low byte
IE	A8H	00h	Interrupt Enable Register
IP	B8H	00h	Interrupt Priority Register 1
XICON	C0H	00h	Interrupt Enable Register (INT2/INT3)
PSW	D0H	00h	Program Status Word
ACC	E0H	00h	Accumulator
B	F0H	00h	B Register

**Note:** Refer to 5.7 “Reset” section for the initial value of SFR.

Introduction of WT51F108S/104S CPU SFR is as below:

**B: Address: F0H**

**Reset Value: 00h**

7	6	5	4	3	2	1	0
B.7	B.6	B.5	B.4	B.3	B.2	B.1	B.0

The B register is used during multiply and divide operations. It can store the multiplier and the high bytes of operation result in multiply operation, and also the divisor and the remainder of operation result in divide operation. The B register can be used as a general register.

**ACC: Address: E0H**

**Reset Value: 00h**

7	6	5	4	3	2	1	0
ACC.7	ACC.6	ACC.5	ACC.4	ACC.3	ACC.2	ACC.1	ACC.0

ACC is the Accumulator register, used for data operations.

**P0: Address: 80H**

**Reset Value: FFh**

7	6	5	4	3	2	1	0
P0.7	P0.6	P0.5	P0.4	P0.3	P0.2	P0.1	P0.0

輸出/輸入端口 P0 的數據設定。

註: 使用 8052 port (P0.x)，必須將對應的 GPIOx\_TYP 設定為開汲極。

**CKCON: Address: 8EH**

**Reset Value: 00h**

7	6	5	4	3	2	1	0
							TCS0

TCS0 = 0: Timer 0 counts once for 12 clocks

TCS0 = 1: Timer 0 counts once for 3 clocks



**PSW (Program Status Word): Address: D0H**
**Reset Value: 00h**

7	6	5	4	3	2	1	0
CY	AC	F0	RS1	RS0	OV	F1	PARITY

The Program Status Word contains program status information.

Bit Number	Bit Mnemonic	Description
7	CY	Carry Flag, used to indicate the result of arithmetic operation whether a carry or borrow occurred in the 7 <sup>th</sup> bit. Operation result of Addition: CY = 1: a carry occurred; CY = 0: no carry occurred. Operation result of Subtraction: CY = 1: a borrow occurred; CY = 0: no borrow occurred.
6	AC	Auxiliary-Carry Flag, used to indicate the result of arithmetic operation whether the 3 <sup>rd</sup> bit borrow (or carry) from the 4 <sup>th</sup> bit occurred. Operation result of Addition: AC = 1: a carry occurred; AC = 0: no carry occurred. Operation result of Subtraction: AC = 1: a carry occurred; AC = 0: no carry occurred.
5	F0	General purpose flag, can be served as general purpose read/write bit.
4	RS1	Register Bank Select bits 1 and 0 (refer to Register Bank Selection Table).
3	RS0	
2	OV	Overflow Flag, used to indicate the result of arithmetic operation whether an overflow occurred. If OV = 1, an overflow occurred. Otherwise, it is cleared.
1	F1	General-purpose flag, can be used as normal read/write bit.
0	P	Parity Flag. It is set to indicate an odd number of "1" bits in the accumulator. Otherwise, it is cleared.

**Register Bank Selection Table:**

Register Bank	Address	RS1	RS0
0	00H ~ 07H	0	0
1	08H ~ 0FH	0	1
2	10H ~ 17H	1	0
3	18H ~ 1FH	1	1

**SP (Stack Point) Address: 81H**
**Reset Value: 07h**

7	6	5	4	3	2	1	0
SP.7	SP.6	SP.5	SP.4	SP.3	SP.2	SP.1	SP.0

Stack Pointer, indicated the location at which the last byte was pushed onto the stack. It is incremented before data is stored during PUSH.

**DPL0 (DPTR0, low byte of the 16-bit data pointer 0) Address: 82H Reset Value: 00h**

7	6	5	4	3	2	1	0
DPL0.7	DPL0.6	DPL0.5	DPL0.4	DPL0.3	DPL0.2	DPL0.1	DPL0.0

DPL0 is a low byte of DPTR0, using together with the data pointer of DPH0.

**DPH0 (DPTR0, high byte of the 16-bit data pointer 0) Address: 83H Reset Value: 00h**

7	6	5	4	3	2	1	0
DPH0.7	DPH0.6	DPH0.5	DPH0.4	DPH0.3	DPH0.2	DPH0.1	DPH0.0

DPH0 is a high byte of DPTR0, using together with the data pointer of DPL0.

**Note: Other special function registers will be discussed in later sections.**

## 5.5 In-System Programming (ISP) (Important!!! Must Read!!!)

In-System Programming function allows users to perform programming on the target board directly without removing any components.

**ISP interface adopts:**

3-wire: VDD, GND (VSS), SWUT

2-wire: SWUT, GND (VSS), if the target board already has VDD power.

The figure below illustrates pins of ISP interface:

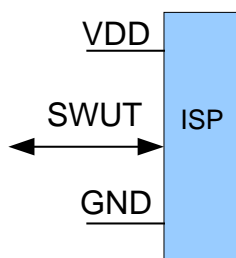

**Note:** See WT51F108S/104S WLINK-SWUT ISP User's Manual for more details.

### 5.5.1 In-System Programming Notice

Condition: When SOURCE clock of WT51F108S/104S is 12 MHz (Internal/External Oscillator), it is stable to proceed In-System Programming. For more details, please refer to Chapter 8 Application Circuits.

Description: Since this series of MCU adopts single-wire UART (SWUT) for In-Sytem Programming and the baud rate is 115200 bps, SOURCE clock of WT51F108S/104S must work at Internal Oscillator (12 MHz) or External Oscillator (2~24 MHz).

In addition, the default setting of WT51F108S/104S is IRC 12 MHz, and thus direct In-System Programming is supported. It requires adding trigger or wakeup conditions if WT51F108S/104S works at Internal RC Oscillator (24 MHz), External Oscilaltor (<2 MHz, 32768 Hz), Green Mode, Idle Mode or Sleep Mode, otherwise programming procedures will fail. The following section will explain how to operate in those modes. (For more details on reference clock source of ISP, please refer to section 3.1)

GPIOxx/RESET/SWUT pin supports Reset function/Input/Programming function at the same time, but each level is different, please refer to the table below:

Function (VDD = 5.0V)	VIH	VIL	Function (VDD = 3.5V)	VIH	VIL
SWUT	0.83 VDD	0.57 VDD	SWUT	0.81 VDD	0.52 VDD
NRST	0.45 VDD	0.24 VDD	NRST	0.49 VDD	0.27 VDD

**The programming voltage of SWUT ranging between 2.2V and 5.5V. If the programming voltage is below 2.7V, the internal pull high of GPIOA3 pin must be disabled. (XFR 0x1C GPIOA\_PHN[3])**

### **Normal Mode:**

If the SOURCE clock of WT51F108S/104S works at Internal Oscillator (12 MHz) or External Oscillator (2~24 MHz), and WT51F108S/104S performs Power On Reset normally, the programming process can go smoothly.

Please pay more attention to the following two conditions:

- (1) When the Source Clock of WT51F108S/104S selects External Oscillator and works together with particular frequency external crystal oscillator (< 2 MHz or 32.768 kHz) Since the SWUT baud rate is not 115200 bps, WT51F108S/104S cannot perform programming directly.
- (2) Or when the SOURCE clock of WT51F108S/104S works at Internal Oscillator (24 MHz), due to the power supply with greater noises, thereby affecting the accuracy of SWUT baud rate will lead to the programming failure of WT51F108S/104S.

Above conditions are required to set ISP clock source control register (ISP\_CHG\_CTL) to enable two control bits Bit7 ISP\_CHG\_12M and Bit5 UART\_ISP\_CHG, which allows SWUT pin to receive trigger signals. After WT51F108S/104S being switched to Internal 12 MHz automatically, the programming process will succeed. For more details, please refer to section 6.7 (XFR\_0x04 "mandatory trigger SWUT setup procedure").

### **Green Mode**

It is so-called Green Mode when MCU works at 32 kHz (Internal/External Oscillator). MCU cannot perform programming directly when works at this mode. It requires setting ISP Clock Source Control Register (ISP\_CHG\_CTL) to enable two control bits (Bit7 ISP\_CHG\_12M & Bit5 UART\_ISP\_CHG), which allows SWUT pin to receive trigger signal. After the MCU being switched to Internal Oscillator 12 MHz automatically, the programming process will succeed. For more details, please refer to section 6.7.

### **Idle Mode:**

Before entering this mode, in addition to setting ISP Clock Source Control Register (ISP\_CHG\_CTL) to enable two control bits (Bit7 ISP\_CHG\_12M & Bit5 UART\_ISP\_CHG), be sure to set up wakeup conditions. Then MCU can switch back to work at 12 MHz, and maintain 2 ~ 3 seconds to receive the programming command from SWUT. For more details, please refer to section 6.7.

### **Sleep Mode:**

Before entering this mode, in addition to setting ISP Clock Source Control Register (ISP\_CHG\_CTL) to enable two control bits (Bit7 ISP\_CHG\_12M & Bit5 UART\_ISP\_CHG), be sure to set up wakeup conditions. Then MCU can switch back to work at 12 MHz, and maintain 2 ~ 3 seconds to receive the programming command from SWUT. For more details, please refer to section 6.7.

**Recommended Circuit:**

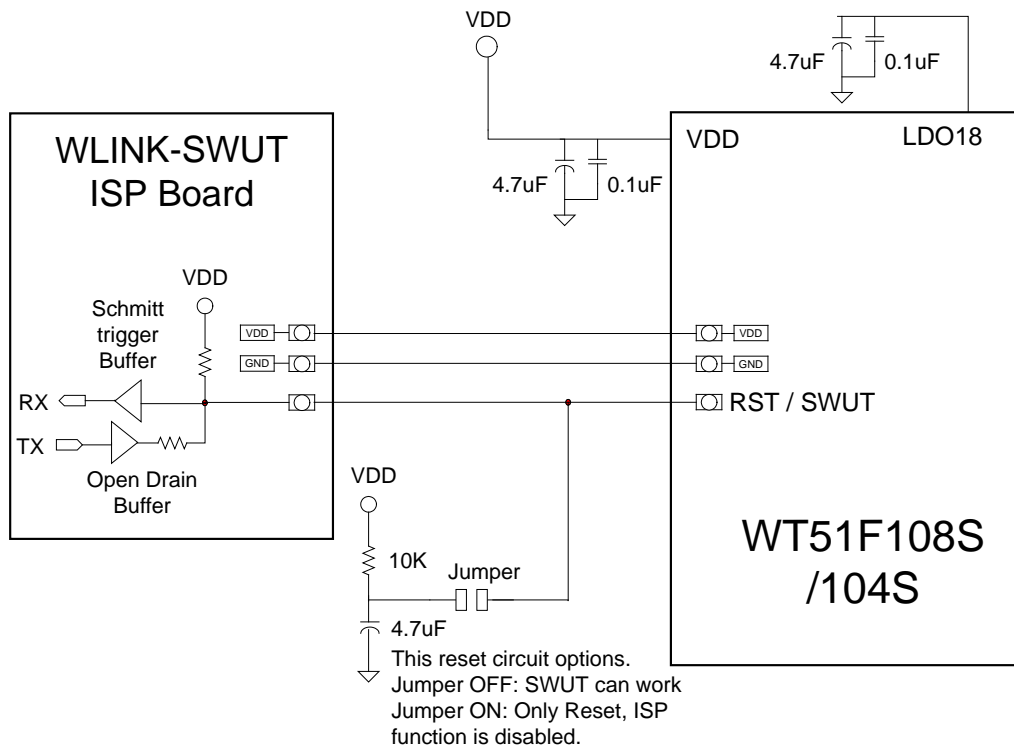

## 5.6 Timer/Counter

The WT51F108S/104S contains one 16-bit Timer/Counters (Timer0). All Timer/Counters can be configured as Timer or Counter.

### 5.6.1 Timer/Counter0 (Timer 0)

The internal Timer/Counter 0 of WT51F108S/104S have four operation modes to be selected by bits M11, M10, or M01, M00 respectively in the Special Function Register TMOD, as described below.

**TMOD (8052 Timer0/1 mode control register) Address: 89H**

7	6	5	4	3	2	1	0
-	-	-	-	GATE0	C0/T0	M01	M00

Bit Number	Bit Mnemonic	Description
7-4	-	Must be 0.
3	GATE0	GATE0 = 1, invalid GATE0 = 0, configured as internal Timer. If TR0 = 1, Timer0 starts.
2	C0/T0	Timer/Counter 0 selector C0/T0 = 1, configured as an external Counter, and the counter signal is from external pin (GPIOA2/T0) input (the maximum input frequency is 500 kHz) C0/T0 = 0, configured as an internal Timer, and the counter signal is from MCU Clock 12 MHz IRC ÷ 12
1-0	M01-M00	Timer/Counter 0 mode selection bits 00: Mode 0, 13-bit Timer/Counter 01: Mode 1, 16-bit Timer/Counter 10: Mode 2, 8-bit auto-reload Timer/Counter 11: Mode 3, 8-bit Timer/Counter (TL0 uses TR0 bit and TH0 uses TR1 bit)

**TCON (8052 Timer 0 control register) Address: 88H**

7	6	5	4	3	2	1	0
-	-	TF0	TR0	-	-	-	-

Bit Number	Bit Mnemonic	Description
7-6	-	Invalid
5	TF0	Timer/Counter 0 Overflow Flag. When the Timer/Counter overflows, TF0 is set (TF0 = 1). When the CPU is jumped to the Interrupt Service Routine of Timer/Counter 0, TF0 is auto-cleared (TF0 = 0).
4	TR0	Timer/Counter 0 Enable bit. If TR0 is set (TR0 = 1), Timer/Counter 0 is in use; If TR0 is disabled (TR0 = 0), Timer/Counter 0 stopped.
3	-	Invalid
2	-	Reserved, must be set as 0.

Bit Number	Bit Mnemonic	Description
1	-	Invalid
0	-	Reserved, must be set as 0.

**Note:** See section 6.4 for more information on Baud rate generator of Timer/Counter 1.

**Mode 0:**

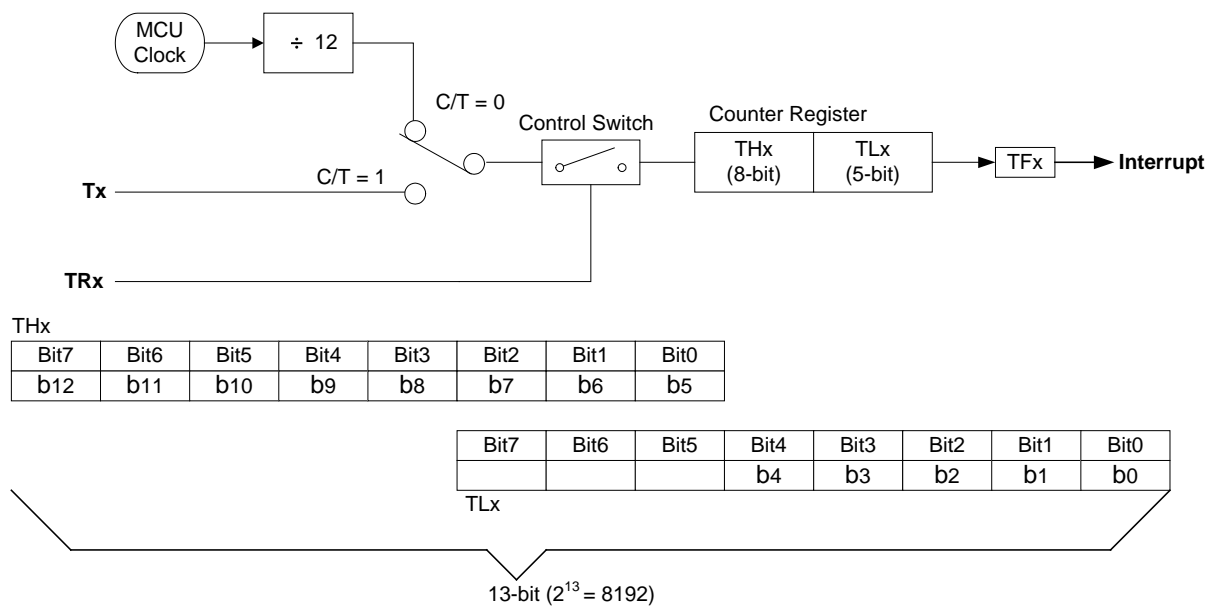

Mode 0 operation is the same for Timer/Counter 0. In this mode, the timer register is configured as a 13-bit Up Timer/Counter, which consists of the Special Function Register THx and TLx. As the count of the 13 bits is all 1s, if the register incremented 1 then count of the 13 bits is all 0s and meantime if the Timer/Counter Interrupt is enabled, an Timer overflow interrupt will occur and Overflow Flag is set (TFx = 1).

**Mode 1:**

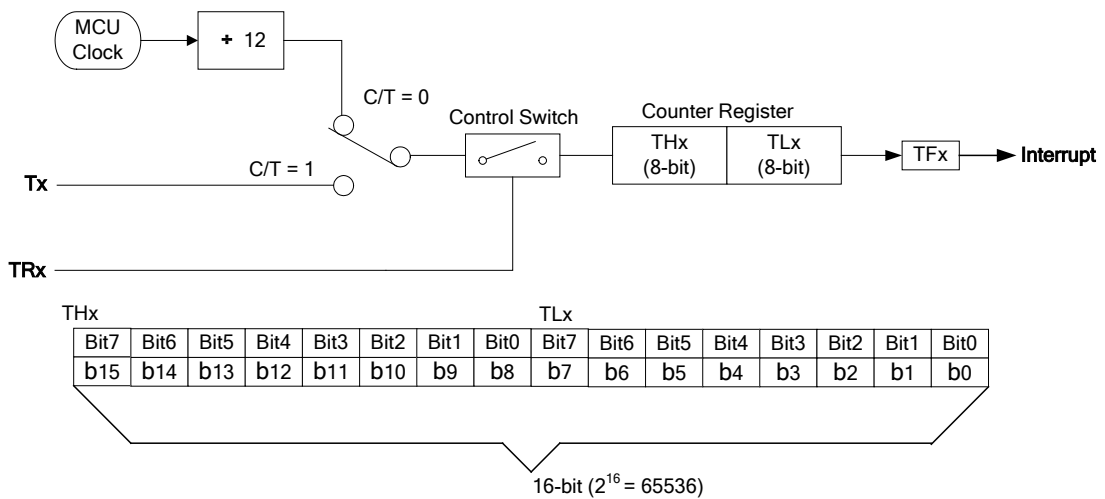

Mode 1 operation is the same as Mode 0 for Timer/Counter 0, except that the Timer Register which consists of THx and TLx is configured as a 16-bit Up Timer/Counter.

**Mode 2:**

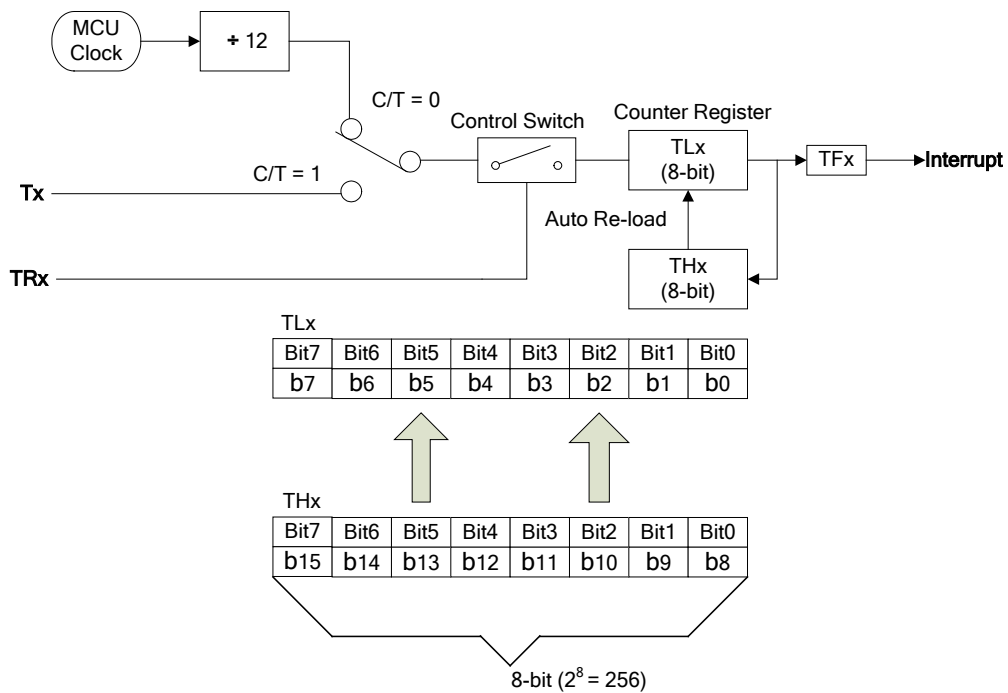

Mode 2 operation for Timer/Counter 0 is to configure two 8-bit auto-reload Timer/Counters. The counter value is stored in TLx Register. Overflow from TLx not only sets TFx = 1, but also auto-reloads contents of THx to TLx.



## 5.7 Reset

The WT51F108S/104S has seven reset generation sources: Power On Reset (POR), Low Voltage Reset (LVR), Low Voltage Detection Reset (LVDR), External NRST Pin Reset, Watchdog Reset, ISP/ICE Command Reset, and PC Counter Overflow Reset (PC\_OVR). During Reset, all registers are reset to their initial values. You may judge what kind of reset is generated by Reset Flag Register (XFR 0x03).

### Power-on Reset (POR)

The Power-on Reset occurs when the VDD supply voltage is below the Power-on Reset voltage threshold (refer to DC Characteristics sections for more details), then XFR: 0x03 POR\_RST\_FLG = 1.

### Low Voltage Reset (LVR)

A reset occurs when the VDD voltage is below the operating voltage threshold, then XFR: 0x03 LVR\_RST\_FLG = 1.

### Low Voltage Detection Reset (LVDR)

A reset occurs when the VDD voltage is below the Low Voltage Detection setting level, then XFR: 0x03 LVD\_RST\_FLG = 1.

### External NRST pin Reset

A reset occurs when the voltage of the external reset pin (NRST) is below its VIL (refer to DC characteristics sections for more details), then XFR: 0x03 NRST\_FLG = 1.

### Watchdog Timer Reset

A reset occurs when the Watchdog Timer times out, then XFR: 0x03 WDT\_RST\_FLG = 1.

### ISP/ICE Command Reset

An ISP/ICE reset occurs when SWUT pin transmitted the reset command, then XFR: 0x03 ISP\_RST\_FLG = 1.

### PC Counter Overflow Reset (PC\_OVR)

The PC counter stores the address where the current instruction locates. A reset occurs when the address exceeds the range of the Flash memory (WT51F108S Flash Address 0x0000 ~ 0x1FFF; WT51F104S Flash Address 0x0000 ~ 0x0FFF), then XFR: 0x03 PC\_OVL\_RST\_FLG = 1.

© **EN\_ADDR\_OVL\_RST (XFR\_0x01\_bit5 = 1) must be enabled first to use this function.**

**Reset status**

When above condition occurred, all Special Function Registers are set to their initial values. SFR contents are described in the following text. XFR contents will be discussed in next section.

The initial value of Special Function Register after Reset (as shown below):

SFR	Initial Value	SFR	Initial Value
P0	11111111b	IE	00000000b
SP	00000111b	IP	xx000000b
DPL0	00000000b	SCON0	00000000b
DPH0	00000000b	SBRG0H	00000000b
PCON	00000000b	SBRG0L	00000000b
TCON	00000000b	PSW	00000000b
TMOD	00000000b	ACC	00000000b
TL0	00000000b	B	00000000b
TL1	00000000b	XICON	00000000b
SCON0	00000000b	SBUF0	00000000b
SBRG0H	00000000b	CKCON	00000000b
SBRG0L	00000000b		

**Reset Flag Register RESET\_FLG (XFR: 0x03)**
**Reset Value: 01h**

Bit	Bit 7	Bit 6	Bit 5	Bit 4	Bit 3	Bit 2	Bit 1	Bit 0
Status	W	R	R	R	R	R	R	R
Name	CLR_RST_FLG	PC_OVL_RST_FLG	ISP_RST_FLG	WDT_RST_FLG	NRST_FLG	LVD_RST_FLG	LVR_RST_FLG	POR_RST_FLG

Bit Number	Bit Mnemonic	Description
7	CLR_RST_FLG	1: Clear all Reset Flag
6	PC_OVL_RST_FLG	1: Reset source is from PC Counter overflow
5	ISP_RST_FLG	1: Reset source is from ISP
4	WDT_RST_FLG	1: Reset source is from Watchdog
3	NRST_FLG	1: Reset source is from External Reset pin
2	LVD_RST_FLG	1: Reset source is from Low Voltage Detection Reset
1	LVR_RST_FLG	1: Reset source is from Low Voltage Reset
0	POR_RST_FLG	1: Reset source is from External Power Reset

## 5.8 System Clock and Clock sources

The WT51F108S/104S contains three clock sources: 32.768 kHz ~ 24 MHz external crystal oscillator, internal 12/24 MHz RC oscillator, and internal 32 kHz RC oscillator. The MCU clock sources are selected by External Special Function Register (XFR) SOURCE\_CLK\_SLT[1:0] and MCU\_CLK\_SLT[1:0]. The initial value is internal 12/24 MHz RC oscillator and without using a prescaler, at the same time MCU works at 12/24 MHz operating frequency. For more details, refer to section 6.7 Power Management.

Clock Sources are listed below.

Main Clock Sources	Sub Clock Sources
DC ~ 24 MHz Crystal Oscillator	32K Internal RC Oscillator
12/24 MHz Internal RC Oscillator	32K Internal RC Oscillator
12/24 MHz Internal RC Oscillator	32.768 kHz Crystal Oscillator

When using the Internal IRC oscillator, 12/24 MHz can be selected as MCU clock source by HFIRC\_CLK\_SLT (XFR\_0x01\_bit2).

IRC oscillator (12M/24M) switching procedures:

- (a) IRC12M change to IRC24M
  - (1) Set HFIRC\_CLK\_SLT
  - (2) Move flash memory XDATA 0x0E07H-bit[6:0] to XFR\_0x70 register
- (b) IRC24M change to IRC12M
  - (1) Clear HFIRC\_CLK\_SLT
  - (2) Move flash memory XDATA 0x0E03H-bit[6:0] to XFR\_0x70 register

### System Control Register SYS\_CTL (XFR: 0x01)

Reset Value: 80h

Bit	Bit 7	Bit 6	Bit 5	Bit 4	Bit 3	Bit 2	Bit 1	Bit 0
Status	R/W	R/W	R/W	R/W	R/W	R/W	R/W	R/W
Name	RST_NDF	LVD_RST_LVL_ADJ	EN_ADDR_OVL_RST	CRY_CLK_DIV2	BGP_VOL_SLT	HFIRC_CLK_SLT	WDT_CLK_SLT	WTMR_CLK_SLT

Bit Number	Bit Mnemonic	Description
7	RST_NDF	1: NRST pin without digital filter function 0: NRST pin with digital filter function (4 clocks)
6	LVD_RST_LVL_ADJ	1: +0.25V 0: +0V
5	ED_ADDR_OVL_RST	1: Enable "PC Counter Overflow Reset" 0: Disable "PC Counter Overflow Reset"
4	CRY_CLK_DIV2	1: Enable "External Crystal Oscillator Prescaler" /2 0: Disable "External Crystal Oscillator Prescaler"
3	BGP_VOL_SLT	1: BandGap = 2.44V 0: BandGap = 1.23V
2	HFIRC_CLK_SLT	1: Internal IRC oscillator = 24 MHz 0: Internal IRC oscillator = 12 MHz

Bit Number	Bit Mnemonic	Description
1	WDT_CLK_SLT	1: Watchdog Timer uses external 24 MHz ~ 32 kHz crystal oscillator 0: Watchdog Timer uses internal 32 kHz RC oscillator
0	WTMR_CLK_SLT	1: Watch Timer uses external 24 MHz ~ 32 kHz crystal oscillator 0: Watch Timer uses internal 32 kHz RC oscillator

-: unimplemented.

## 6. Enhanced Function

### 6.1 External Special Function Register (XFR)

External Special Function Register (XFR) locates from 0x00 ~ 0xFF, must be accessed by the execution of MOVX instruction.

External Special Function Register Table:

External memory address	Description
0000H ~ 000FH	System Register, Low Voltage Detection and Reset Register
0010H ~ 001FH	General-purpose I/O port Register
0020H ~ 002FH	General-purpose I/O port Register and Multi-function Register
0030H ~ 003FH	Interrupt Enable Register
0040H ~ 004FH	External Interrupt Request Register (IRQ)
0050H ~ 005FH	Pulse Width Modulation Register (PWM)
0060H ~ 006FH	Wakeup Register
0070H ~ 007FH	Internal Oscillator Calibration Register, Watchdog Register, Watch Timer Register
00A0H ~ 00A7H	I <sup>2</sup> C Serial Port Interface Register
00B0H ~ 00BFH	Enhanced Timer/Counter Register
00D0H ~ 00D7H	10-bit Analog/Digital Register
00E0H ~ 00EFH	Emulated E <sup>2</sup> PROM Register

When the Reset status which is mentioned in section 5.7 occurred, the default value of external function register after reset is listed below:

Register Name	Address	Reset Default (Hex)	Index Section
Reserved	-	-	
System Control Register	0x01	80	5.8; 6.9; 6.14; 6.15
Low Voltage Detection Control Register	0x02	A6	6.14; 6.15
Reset Flag Register	0x03	01	5.7
ISP Clock Source Control Register	0x04	00	6.7
System Clock Source Control Register	0x05	A0	6.7
Power Saving Control Register	0x06	50	6.7
Clock Source Control Register	0x07	A2	6.7
Oscillator Driver Control Register	0x08	54	6.7
External Clock Source Prescaler Control Register 1	0x09	01	6.9
External Clock Source Prescaler Control Register 2	0x0A	76	6.9

Register Name	Address	Reset Default (Hex)	Index Section
Low Voltage Reset Control Register	0x0C	00	6.13
Customer Code Register 1	0x0D	FF	6.17
Customer Code Register 2	0x0E	FF	6.17
Customer Code Register 3	0x0F	FF	6.17
General-purpose I/O Port A Output Enable Control Register	0x10	00	6.2
General-purpose I/O Port B Output Enable Control Register	0x11	00	6.2
General-purpose I/O Port C Output Enable Control Register	0x12	00	6.2
General-purpose I/O Port D Output Enable Control Register	0x13	00	6.2
General-purpose I/O Port A Data Register	0x16	00	6.2
General-purpose I/O Port B Data Register	0x17	00	6.2
General-purpose I/O Port C Data Register	0x18	00	6.2
General-purpose I/O Port D Data Register	0x19	00	6.2
General-purpose I/O Port A Enable Internal Pull-up Resistor Register	0x1C	FF	6.2
General-purpose I/O Port B Enable Internal Pull-up Resistor Register	0x1D	FF	6.2
General-purpose I/O Port C Enable Internal Pull-up Resistor Register	0x1E	FF	6.2
General-purpose I/O Port D Enable Internal Pull-up Resistor Register	0x1F	3F	6.2
General-purpose I/O Port A Output Type Control Register	0x22	FF	6.2
General-purpose I/O Port B Output Type Control Register	0x23	FF	6.2
General-purpose I/O Port C Output Type Control Register	0x24	FF	6.2
General-purpose I/O Port A Complex Function Setting Register 1	0x25	00	6.2
General-purpose I/O Port A Complex Function Setting Register 2	0x26	00	6.2
General-purpose I/O Port A Complex Function Setting Register 3	0x27	00	6.2
General-purpose I/O Port B Complex Function Setting Register 1	0x28	00	6.2
General-purpose I/O Port B Complex Function Setting Register 2	0x29	00	6.2
General-purpose I/O Port B Complex Function Setting Register 3	0x2A	00	6.2
General-purpose I/O Port C Complex Function Setting Register 1	0x2B	00	6.2
General-purpose I/O Port C Complex Function Setting Register 2	0x2C	00	6.2
General-purpose I/O Port C Complex Function Setting Register 3	0x2D	00	6.2
8052 External Interrupt 0 Control Register	0x30	00	6.3
8052 External Interrupt 1 Control Register	0x31	00	6.3
8052 External Interrupt 2 Control Register	0x32	00	6.3
8052 External Interrupt 3 Control Register	0x34	00	6.3
8052 External Interrupt 0 (INT0) Flag Register	0x35	00	6.3

Register Name	Address	Reset Default (Hex)	Index Section
8052 External Interrupt 1 (INT1) Flag Register	0x36	00	6.3
8052 External Interrupt 2 (INT2) Flag Register	0x37	00	6.3
8052 External Interrupt 3 (INT3) Flag Register	0x39	00	6.3
External Interrupt Request (IRQ) Control Register	0x41	00	6.5
External Interrupt Request (IRQ) Status Register	0x43	00	6.5
External Interrupt Request (IRQ) Clear Register	0x45	00	6.5
External Interrupt Request (IRQ) Bi-directional Trigger Register	0x47	00	6.5
External Interrupt Request (IRQ) Trigger Edge Register	0x49	00	6.5
PWM Control Register 0	0x50	00	6.6
PWM0 Period Control High Bytes Register	0x51	00	6.6
PWM0 Period Control Low Bytes Register	0x52	01	6.6
PWM0 Duty Cycle Control High Bytes Register	0x53	00	6.6
PWM0 Duty Cycle Control Low Bytes Register	0x54	00	6.6
PWM1 Period Control High Bytes Register	0x55	00	6.6
PWM1 Period Control Low Bytes Register	0x56	01	6.6
PWM1 Duty Cycle Control High Bytes Register	0x57	00	6.6
PWM1 Duty Cycle Control Low Bytes Register	0x58	00	6.6
General-purpose I/O Port A Wakeup Control Register	0x60	00	6.7
General-purpose I/O Port B Wakeup Control Register	0x61	00	6.7
Peripheral Interrupt Wakeup Control Register	0x64	00	6.7
General-purpose I/O Port A Wakeup Flag Register	0x65	00	6.7
General-purpose I/O Port B Wakeup Flag Register	0x66	00	6.7
Peripheral Interrupt Wakeup Flag Register	0x69	00	6.7
Wakeup Clear Register	0x6A	00	6.7
Internal Oscillator Adjust Register	0x70	40	6.8
Internal Oscillator Counter Data High Bytes Register	0x71	00	6.8
Internal Oscillator Counter Data Low Bytes Register	0x72	00	6.8
Internal Oscillator Calibration Control Register	0x73	00	6.8
Internal Oscillator Calibration Compare Data Register	0x74	5B	6.8
Watchdog Timer Control Register	0x78	02	6.9
Watch Timer Control Register	0x7C	80	6.9
Watch Timer Output Selection Register	0x7D	00	6.9
Slave I <sup>2</sup> C Control Register	0xA0	40	6.10
Slave I <sup>2</sup> C Status Register	0xA1	00	6.10
Slave I <sup>2</sup> C Transmit Buffer Register	0xA2	00	6.10

Register Name	Address	Reset Default (Hex)	Index Section
Slave I <sup>2</sup> C Transmit and Receive Buffer Register	0xA3	FF	6.10
Slave I <sup>2</sup> C Address Register	0xA4	00	6.10
Enhanced Timer/Counter Control Register 1	0xB0	00	6.11
Enhanced Timer/Counter Control Register 2	0xB1	00	6.11
Enhanced Timer/Counter Interrupt Register	0xB2	00	6.11
Enhanced Timer/Counter Data Buffer Low Bytes Register	0xB3	00	6.11
Enhanced Timer/Counter Data Buffer High Bytes Register	0xB4	80	6.11
ADC Control Register	0xD0	80	6.12
ADC Setting Control Register	0xD1	40	6.12
ADC Interrupt Control Register	0xD2	00	6.12
ADC Channel Control Register	0xD3	00	6.12
ADC Voltage Compare Data High Bytes Register	0xD4	80	6.12
ADC Voltage Compare Data Low Bytes Register	0xD5	00	6.12
ADC Converted Data High Bytes Register	0xD6	00	6.12
ADC Converted Data Low Bytes Register	0xD7	00	6.12
E <sup>2</sup> PROM Enable Register 1	0xE0	00	6.16
E <sup>2</sup> PROM Enable Register 2	0xE1	00	6.16
E <sup>2</sup> PROM Address Low Bytes Register	0xE2	FF	6.16
E <sup>2</sup> PROM Address High Bytes Register	0xE3	07	6.16
E <sup>2</sup> PROM Control Register	0xE4	08	6.16
E <sup>2</sup> PROM Break Register	0xE6	00	6.16
E <sup>2</sup> PROM Data Register	0xE8	00	6.16



## 6.2 I/O Port

### 6.2.1 Features

- ◆ 29 programmable I/O, contains: GPIOA[7:0], GPIOB[7:1], GPIOC[7:0], GPIOD[5:0]
- ◆ Some I/O with special functions (such as IRQ, ADC, and PWM etc.), can be configured by Special Function Register

### 6.2.2 Register

WT51F108S/104S I/O related registers are classified into four categories:

- ◆ GPIOx\_OE: Control Output/Input Register, configured to set I/O as output or input. If the corresponding bit GPIOx\_OE = 1, it is an output port with 4mA driving ability
- ◆ GPIOx\_D: Data Register, reading I/O data or set output of I/O
- ◆ GPIOx\_PHN: Internal Pull-up Resistor Enable Register. When I/O is configured as Input port (by GPIOx\_OE), this register is allowed to set if I/O is with pull-up resistor. If the corresponding GPIOx\_PHN bit = 0, the I/O is with internal pull-up resistor.
- ◆ GPIOx\_TYP: Output mode setting Register, is configured to set I/O as Push-Pull or Open Drain type.

#### General-purpose I/O Port A Output Enable Control Register GPIOA\_OE (XFR: 0x10) Reset Value: 00h

Bit	Bit 7	Bit 6	Bit 5	Bit 4	Bit 3	Bit 2	Bit 1	Bit 0
Status	R/W	R/W	R/W	R/W	R/W	R/W	R/W	R/W
Name	GPIOA_OE[7:0]							

Bit Number	Bit Mnemonic	Description
7-4	GPIOA_OE[7:4]	General-purpose I/O Port A Output/Input setting 1: Output 0: Input (default)
3	GPIOA_OE[3]	General-purpose I/O Port A Output/Input setting 0: Input (default) <b>Note: Input mode only</b>
2-0	GPIOA_OE[2:0]	General-purpose I/O Port A Output/Input setting 1: Output 0: Input (default)

- : unimplemented.

#### General-purpose I/O Port B Output Enable Control Register GPIOB\_OE (XFR: 0x11) Reset Value: 00h

Bit	Bit 7	Bit 6	Bit 5	Bit 4	Bit 3	Bit 2	Bit 1	Bit 0
Status	R/W	R/W	R/W	R/W	R/W	R/W	R/W	-
Name	GPIOB_OE[7:1]							Reserved

Bit Number	Bit Mnemonic	Description
7-1	GPIOB_OE[7:1]	General-purpose I/O Port B Output/Input setting 1: Output 0: Input (default)
0	Reserved	-

- : unimplemented.

**General-purpose I/O Port C Output Enable Control Register GPIOC\_OE (XFR: 0x12) Reset Value: 00h**

Bit	Bit 7	Bit 6	Bit 5	Bit 4	Bit 3	Bit 2	Bit 1	Bit 0
Status	R/W	R/W	R/W	R/W	R/W	R/W	R/W	R/W
Name	GPIOC_OE[7:0]							

Bit Number	Bit Mnemonic	Description
7-0	GPIOC_OE[7:0]	General-purpose I/O Port C Output/Input setting 1: Output 0: Input (default)

- : unimplemented.

**General-purpose I/O Port D Output Enable Control Register GPIOD\_OE (XFR: 0x13) Reset Value: 00h**

Bit	Bit 7	Bit 6	Bit 5	Bit 4	Bit 3	Bit 2	Bit 1	Bit 0
Status	-	-	R/W	R/W	R/W	R/W	R/W	R/W
Name	Reserved		GPIOD_OE[5:0]					

Bit Number	Bit Mnemonic	Description
7-6	Reserved	-
5-0	GPIOD_OE[5:0]	General-purpose I/O Port C Output/Input setting 1: Output 0: Input (default)

- : unimplemented.

**General-purpose I/O Port A Data Register GPIOA\_D (XFR: 0x16) Reset Value: 00h**

Bit	Bit 7	Bit 6	Bit 5	Bit 4	Bit 3	Bit 2	Bit 1	Bit 0
Status	R/W	R/W	R/W	R/W	R/W	R/W	R/W	R/W
Name	GPIOA_D[7:0]							

Bit Number	Bit Mnemonic	Description
7-4	GPIOA_D[7:4]	General-purpose I/O Port A Output/Input data

Bit Number	Bit Mnemonic	Description
3	GPIOA_D[3]	GPIA3 is input only pin
2-0	GPIOA_D[2:0]	General-purpose I/O Port A Output/Input data

-: unimplemented.

**General-purpose I/O Port B Data Register GPIOB\_D (XFR: 0x17) Reset Value: 00h**

Bit	Bit 7	Bit 6	Bit 5	Bit 4	Bit 3	Bit 2	Bit 1	Bit 0
Status	R/W	R/W	R/W	R/W	R/W	R/W	R/W	-
Name	GPIOB_D[7:1]							Reserved

Bit Number	Bit Mnemonic	Description
7-1	GPIOB_D[7:1]	General-purpose I/O Port B Output/Input data
0	Reserved	-

-: unimplemented.

**General-purpose I/O Port C Data Register GPIOC\_D (XFR: 0x18) Reset Value: 00h**

Bit	Bit 7	Bit 6	Bit 5	Bit 4	Bit 3	Bit 2	Bit 1	Bit 0
Status	R/W	R/W	R/W	R/W	R/W	R/W	R/W	R/W
Name	GPIOC_D[7:0]							

Bit Number	Bit Mnemonic	Description
7-0	GPIOC_D[7:0]	General-purpose I/O Port C Output/Input data

-: unimplemented.

**General-purpose I/O Port D Data Register GPIOD\_D (XFR: 0x19) Reset Value: 00h**

Bit	Bit 7	Bit 6	Bit 5	Bit 4	Bit 3	Bit 2	Bit 1	Bit 0
Status	-	-	R/W	R/W	R/W	R/W	R/W	R/W
Name	Reserved		GPIOD_D[5:0]					

Bit Number	Bit Mnemonic	Description
7-6	Reserved	-
5-0	GPIOD_D[5:0]	General-purpose I/O Port D Output/Input data

-: unimplemented.

**General-purpose I/O Port A Enable Internal Pull-up Resistor GPIOA\_PHN (XFR: 0x1C) Reset Value: FFh**

Bit	Bit 7	Bit 6	Bit 5	Bit 4	Bit 3	Bit 2	Bit 1	Bit 0
Status	R/W	R/W	R/W	R/W	R/W	R/W	R/W	R/W
Name	GPIOA_PHN[7:0]							

Bit Number	Bit Mnemonic	Description
7-0	GPIOA_PHN[7:0]	Enable General-purpose I/O Port A Pull-up Resistor setting 1: Disable Pull-up Resistor (default) 0: Enable Pull-up Resistor

∴ unimplemented.

**General-purpose I/O Port B Enable Internal Pull-up Resistor GPIOB\_PHN (XFR: 0x1D) Reset Value: FFh**

Bit	Bit 7	Bit 6	Bit 5	Bit 4	Bit 3	Bit 2	Bit 1	Bit 0
Status	R/W	R/W	R/W	R/W	R/W	R/W	R/W	-
Name	GPIOB_PHN[7:1]							Reserved

Bit Number	Bit Mnemonic	Description
7-1	GPIOB_PHN[7:1]	Enable General-purpose I/O Port B Pull-up Resistor setting 1: Disable Pull-up Resistor (default) 0: Enable Pull-up Resistor
0	Reserved	-

∴ unimplemented.

**General-purpose I/O Port C Enable Internal Pull-up Resistor GPIOC\_PHN (XFR: 0x1E) Reset Value: FFh**

Bit	Bit 7	Bit 6	Bit 5	Bit 4	Bit 3	Bit 2	Bit 1	Bit 0
Status	R/W	R/W	R/W	R/W	R/W	R/W	R/W	R/W
Name	GPIOC_PHN[7:0]							

Bit Number	Bit Mnemonic	Description
7-0	GPIOC_PHN[7:0]	Enable General-purpose I/O Port C Pull-up Resistor setting 1: Disable Pull-up Resistor (default) 0: Enable Pull-up Resistor

∴ unimplemented.

**General-purpose I/O Port D Enable Internal Pull-up Resistor GPIOD\_PHN (XFR: 0x1F) Reset Value: 3Fh**

Bit	Bit 7	Bit 6	Bit 5	Bit 4	Bit 3	Bit 2	Bit 1	Bit 0
Status	-	-	R/W	R/W	R/W	R/W	R/W	R/W
Name	Reserved		GPIOD_PHN[5:0]					

Bit Number	Bit Mnemonic	Description
7-6	Reserved	-
5-0	GPIOD_PHN[5:0]	Enable General-purpose I/O Port D Pull-up Resistor setting 1: Disable Pull-up Resistor (default) 0: Enable Pull-up Resistor

:- unimplemented.

**General-purpose I/O Port A Output Type Control Register GPIOA\_TYP (XFR: 0x22)      Reset Value: FFh**

Bit	Bit 7	Bit 6	Bit 5	Bit 4	Bit 3	Bit 2	Bit 1	Bit 0
Status	R/W	R/W	R/W	R/W	-	R/W	R/W	R/W
Name	GPIOA_TYP[7:4]			Reserved	GPIOA_TYP[2:0]			

Bit Number	Bit Mnemonic	Description
3	Reserved	-
7-4	GPIOA_TYP[7:4]	General-purpose I/O Port A output type setting 1: Push-pull output type (default) 0: Open-drain output type
2-0	GPIOA_TYP[2:0]	

:- unimplemented.

**General-purpose I/O Port B Output Type Control Register GPIOB\_TYP (XFR: 0x23)      Reset Value: FFh**

Bit	Bit 7	Bit 6	Bit 5	Bit 4	Bit 3	Bit 2	Bit 1	Bit 0
Status	R/W	R/W	R/W	R/W	R/W	R/W	R/W	-
Name	GPIOB_TYP[7:1]							Reserved

Bit Number	Bit Mnemonic	Description
7-1	GPIOB_TYP[7:1]	General-purpose I/O Port B output type setting 1: Push-pull output type (default) 0: Open-drain output type
0	Reserved	-

:- unimplemented.

**General-purpose I/O Port C Output Type Control Register GPIOC\_TYP (XFR: 0x24)      Reset Value: FFh**

Bit	Bit 7	Bit 6	Bit 5	Bit 4	Bit 3	Bit 2	Bit 1	Bit 0
Status	R/W	R/W	R/W	R/W	R/W	R/W	R/W	R/W
Name	GPIOC_TYP[7:0]							

Bit Number	Bit Mnemonic	Description
7-0	GPIOC_TYP[7:0]	General-purpose I/O Port C output type setting 1: Push-pull output type (default) 0: Open-drain output type

:- unimplemented.

### 6.2.3 Port Sharing

This is used to set I/O functions, such as I<sup>2</sup>C, PWM, ADC, etc.

**General-purpose I/O Port A Complex Function Setting Register 1 GPIOA\_FUN1 (XFR: 0x25) Reset Value: 00h**

Bit	Bit 7	Bit 6	Bit 5	Bit 4	Bit 3	Bit 2	Bit 1	Bit 0
Status	-	R/W	R/W	R/W	-	R/W	R/W	R/W
Name	Reserved	GPA5_FUN_SLT[2:0]			Reserved	GPA4_FUN_SLT[2:0]		

Bit Number	Bit Mnemonic	Description
7	Reserved	-
6-4	GPA5_FUN_SLT[2:0]	Set GPIOA5DH complex function 000: GPIO/ETMID (default) (*Notes 1) 001: ADC15 input 011: PWM1 output of Path B <b>101: P00 output/input (mapping to 8052 P0.0) (*Notes 2)</b> Note: If GPIOA4 = OCSO, the complex function of GPIOA5 will be invalid.
3	Reserved	-
2-0	GPA4_FUN_SLT[2:0]	Set GPIOA4DH complex function 000: GPIO/ETMIA (default) (*Notes 1) 001: ADC14 input 010: OSCO (served as external crystal oscillator output pin, and was forced to set GPIOA5DH as external crystal oscillator input pin (OSCI) instead of GPIO function) (*Notes 3) 011: PWM0 output of Path B 101: P01 output/input (mapping to 8052 P0.1) (*Notes 2)

:- unimplemented.

**Notes 1:** While using the external input pins (ETMID & ETMIA) of the Enhanced Timer/Counter, please set GPIOA5/GPIOA4 as GPIO of input mode.

**Notes 2:** While using 8052 port (P0.x) or UART, please set the mapping GPIOx\_TYP as open drain, and add external pull-high resistor.

**Notes 3:** The setting of using External Crystal Oscillator as SOURCE clock:

1. Set GPIOA5 and GPIOA4 as Input port. (XFR 0x10 GPIOA\_OE[5:4])
2. GPIOA5 and GPIOA4 disable internal pull high resistor. If enable pull high resistor will result in oscillator outputs unstable frequency. (XFR 0x1C GPIOA\_PHN[5:4])
3. Set GPIOA4 as OSCO crystal oscillator pin. (XFR 0x25 GPA4\_FUN\_SLT[2:0])
4. Set the complex function of GPIOA5 as GPIO. (XFR 0x25 GPA5\_FUN\_SLT[2:0])
5. Set the driving ability of External Crystal Oscillator. (XFR 0x08 CRY\_12M\_DR[1:0])
6. Power on External Crystal Oscillator switch. (XFR 0x07 CRY\_12M\_PD)
7. Switch SOURCE clock to External Crystal Oscillator. (XFR 0x05 SOURCE\_CLK\_SLT[1:0])

**General-purpose I/O Port A Complex Function Setting Register 2 GPIOA\_FUN2 (XFR: 0x26)      Reset Value: 00h**

Bit	Bit 7	Bit 6	Bit 5	Bit 4	Bit 3	Bit 2	Bit 1	Bit 0
Status	-	R/W	R/W	R/W	-	R/W	R/W	R/W
Name	Reserved	GPA3_FUN_SLT[2:0]			Reserved	GPA2_FUN_SLT[2:0]		

Bit Number	Bit Mnemonic	Description
7	Reserved	-
6-4	GPA3_FUN_SLT[2:0]	Set GPA3D complex function 000: GPIO/ETMIB (default)(Note) 001: ADC13 input 010: Reset pin (NRST) input
3	Reserved	-
2-0	GPA2_FUN_SLT[2:0]	Set GPIOA2DH complex function 000: GPIO/IRQ2/ <b>ETMIC</b> (default) (Note) 001: ADC2 input 010: CMPO, Comparator output 011: PWM1 output of Path C 101: T0 input

-: unimplemented.

**Note: While using the external input pins (ETMIB & ETMIC) of the Enhanced Timer/Counter, please set GPIOA5/GPIOA4 as GPIO of input mode.**

**General-purpose I/O Port A Complex Function Setting Register 3 GPIOA\_FUN3 (XFR: 0x27)      Reset Value: 00h**

Bit	Bit 7	Bit 6	Bit 5	Bit 4	Bit 3	Bit 2	Bit 1	Bit 0
Status	-	R/W	R/W	R/W	-	R/W	R/W	R/W
Name	Reserved	GPA1_FUN_SLT[2:0]			Reserved	GPA0_FUN_SLT[2:0]		

Bit Number	Bit Mnemonic	Description
7	Reserved	-
6-4	GPA1_FUN_SLT[2:0]	Set GPIOA1DH complex function 000: GPIO/IRQ1 (default) 001: ADC1 input or VREF input 100: RX0B, RX of Path B of UART0 (*Note) 101: I <sup>2</sup> C SCL input/output pin (*Note)  Note: ADC1 input can be selected by EN_AD[3:0] of ADC Channel Control Register; while VREF input can be selected by ADC_VREF_SEL[1:0] of ADC Setting Control Register.
3	Reserved	-
2-0	GPA0_FUN_SLT[2:0]	Set GPIOA0DH complex function 000: GPIO/IRQ0 (default) 001: ADC0 input 011: PWM0 output of Path C 100: TX0B, TX of Path B of UART0 (*Note) 101: I <sup>2</sup> C SDA input/output pin (*Note)

-: unimplemented.

**Note:** While using 8052 port (P0.x), I<sup>2</sup>C or UART, please set the mapping GPIOx\_TYP as open drain, and add external pull-high resistor.

**General-purpose I/O Port B Complex Function Setting Register 1 GPIOB\_FUN1 (XFR: 0x28)      Reset Value: 00h**

Bit	Bit 7	Bit 6	Bit 5	Bit 4	Bit 3	Bit 2	Bit 1	Bit 0
Status	-	R/W	R/W	R/W	-	R/W	R/W	R/W
Name	Reserved	GPB5_FUN_SLT[2:0]			Reserved	GPB4_FUN_SLT[2:0]		

Bit Number	Bit Mnemonic	Description
7	Reserved	-
6-4	GPB5_FUN_SLT[2:0]	Set GPIOB5 complex function 000: GPIO/IRQ3 (default) 001: ADC12 input 010: RX0A, RX of Path A of UART0 (*Note) 011: PWM1 output of Path A <b>101: P02 output/input (mapping to 8052 P0.2) (*Note)</b>
3	Reserved	-
2-0	GPB4_FUN_SLT[2:0]	Set GPIOB4 complex function 000: GPIO (default) 001: ADC11 input 010: TX0A, TX of Path A of UART0 (*Note) 011: PWM1 output of Path D 101: P03 output/input (mapping to 8052 P0.3) (*Note) <b>Note: If GPIOB5 = RX0A, GPB4_FUN_SLT will auto select TX0A, and the complex function of ADC11/PWM1D will be invalid.</b>

-: unimplemented.

**Note:** While using 8052 port (P0.x) or UART, please set the mapping GPIOx\_TYP as open drain, and add external pull-high resistor.

**General-purpose I/O Port B Complex Function Setting Register 2 GPIOB\_FUN2 (XFR: 0x29)      Reset Value: 00h**

Bit	Bit 7	Bit 6	Bit 5	Bit 4	Bit 3	Bit 2	Bit 1	Bit 0
Status	-	R/W	R/W	R/W	-	R/W	R/W	R/W
Name	Reserved	GPB3_FUN_SLT[2:0]			Reserved	GPB2_FUN_SLT[2:0]		

Bit Number	Bit Mnemonic	Description
7	Reserved	-
6-4	GPB3_FUN_SLT[2:0]	Set GPIOB3 complex function 000: GPIO (default) 001: ADC10 input 011: PWM0 output of Path A
3	Reserved	-
2-0	GPB2_FUN_SLT[2:0]	Set GPIOB2 complex function 000: GPIO (default) 001: ADC5 input



Bit Number	Bit Mnemonic	Description
		011: PWM0 output of Path D

-: unimplemented.

**General-purpose I/O Port B Complex Function Setting Register 3 GPIOB\_FUN3 (XFR: 0x2A)      Reset Value: 00h**

Bit	Bit 7	Bit 6	Bit 5	Bit 4	Bit 3	Bit 2	Bit 1	Bit 0
Status	-	R/W	R/W	R/W	-	-	-	-
Name	Reserved	GPB1_FUN_SLT[2:0]			Reserved			

Bit Number	Bit Mnemonic	Description
7	Reserved	-
6-4	GPB1_FUN_SLT[2:0]	Set GPIOB1 complex function 000: GPIO/IRQ4 (default) 001: ADC4 input
3-0	Reserved	-

-: unimplemented.

**General-purpose I/O Port C Complex Function Setting Register 1 GPIOC\_FUN1 (XFR: 0x2B)      Reset Value: 00h**

Bit	Bit 7	Bit 6	Bit 5	Bit 4	Bit 3	Bit 2	Bit 1	Bit 0
Status	-	R/W	R/W	R/W	-	R/W	R/W	R/W
Name	Reserved	GPC5_FUN_SLT[2:0]			Reserved	GPC4_FUN_SLT[2:0]		

Bit Number	Bit Mnemonic	Description
7	Reserved	-
6-4	GPC5_FUN_SLT[2:0]	Set GPIOC5 complex function 000: GPIO (default) 001: ADC9 input
3	Reserved	-
2-0	GPC4_FUN_SLT[2:0]	Set GPIOC4 complex function 000: GPIO (default) 001: ADC8 input

-: unimplemented.

**General-purpose I/O Port C Complex Function Setting Register 2 GPIOC\_FUN2 (XFR: 0x2C)      Reset Value: 00h**

Bit	Bit 7	Bit 6	Bit 5	Bit 4	Bit 3	Bit 2	Bit 1	Bit 0
Status	-	R/W	R/W	R/W	-	R/W	R/W	R/W
Name	Reserved	GPC3_FUN_SLT[2:0]			Reserved	GPC2_FUN_SLT[2:0]		

Bit Number	Bit Mnemonic	Description
7	Reserved	-
6-4	GPC3_FUN_SLT[2:0]	Set GPIOC3 complex function 000: GPIO (default)

Bit Number	Bit Mnemonic	Description
		101: P07 output/input (mapping to 8052 P0.7) (*Note)
3	Reserved	-
2-0	GPC2_FUN_SLT[2:0]	Set GPIOC2 complex function 000: GPIO (default) 001: AD3 101: P06 output/input (mapping to 8052 P0.6) (*Note)

-: unimplemented.

**Note:** While using 8052 port (P0.x) or UART, please set the mapping GPIOx\_TYP as open drain, and add external pull-high resistor.

**General-purpose I/O Port C Complex Function Setting Register 3 GPIOC\_FUN3 (XFR: 0x2D)      Reset Value: 00h**

Bit	Bit 7	Bit 6	Bit 5	Bit 4	Bit 3	Bit 2	Bit 1	Bit 0
Status	-	R/W	R/W	R/W	-	R/W	R/W	R/W
Name	Reserved	GPC1_FUN_SLT[2:0]			Reserved	GPC0_FUN_SLT[2:0]		

Bit Number	Bit Mnemonic	Description
7	Reserved	-
6-4	GPC1_FUN_SLT[2:0]	Set GPIOC1 complex function 000: GPIO/IRQ7 (default) 001: ADC7 input 101: P05 output/input (mapping to 8052 P0.5) (*Note)
3	Reserved	-
2-0	GPC0_FUN_SLT[2:0]	Set GPIOC0 complex function 000: GPIO/IRQ6 (default) 001: ADC6 input 101: P04 output/input (mapping to 8052 P0.4) (*Note)

-: unimplemented.

**Note:** While using 8052 port (P0.x) or UART, please set the mapping GPIOx\_TYP as open drain, and add external pull-high resistor.

**ADC Complex Function Setting Table:**

ADC	Register Setting	Shared with GPIO
ADC15	GPA5_FUN_SLT[2:0] = 001	GPIOA5
ADC14	GPA4_FUN_SLT[2:0] = 001	GPIOA4
ADC13	GPA3_FUN_SLT[2:0] = 001	GPIOA3
ADC12	GPB5_FUN_SLT[2:0] = 001	GPIOB5
ADC11	GPB4_FUN_SLT[2:0] = 001	GPIOB4
ADC10	GPB3_FUN_SLT[2:0] = 001	GPIOB3
ADC9	GPC5_FUN_SLT[2:0] = 001	GPIOC5
ADC8	GPC4_FUN_SLT[2:0] = 001	GPIOC4
ADC7	GPC1_FUN_SLT[2:0] = 001	GPIOC1
ADC6	GPC0_FUN_SLT[2:0] = 001	GPIOC0
ADC5	GPB2_FUN_SLT[2:0] = 001	GPIOB2
ADC4	GPB1_FUN_SLT[2:0] = 001	GPIOB1
ADC3	GPC2_FUN_SLT[2:0] = 001	GPIOC2
ADC2	GPA2_FUN_SLT[2:0] = 001	GPIOA2
ADC1	GPA1_FUN_SLT[2:0] = 001	GPIOA1
ADC0	GPA0_FUN_SLT[2:0] = 001	GPIOA0

**ADC VREF Complex Function Setting Table:**

ADC VREF	Register Setting	Shared with GPIO
VREF	GPA1_FUN_SLT[2:0] = 001	GPIOA1

**Crystal Oscillator Complex Function Setting Table:**

CLKIO	Register Setting	Shared with GPIO
OSCO	GPA4_FUN_SLT[2:0] = 010	GPIOA4
OSCI	GPA4_FUN_SLT[2:0] = 010	GPIOA5

**UART Complex Function Setting Table:**

UART	Register Setting	Shared with GPIO
RX0A	GPB5_FUN_SLT[2:0] = 010	GPIOB5
TX0A	GPB4_FUN_SLT[2:0] = 010	GPIOB4
RX0B	GPA1_FUN_SLT[2:0] = 100	GPIOA1
TX0B	GPA0_FUN_SLT[2:0] = 100	GPIOA0

**Note: While using 8052 port (P0.x) or UART, please set the mapping GPIOx\_TYP as open drain, and add external pull-high resistor.**

**I<sup>2</sup>C Complex Function Setting Table:**

I <sup>2</sup> C	Register Setting	Shared with GPIO
SDA	GPA0_FUN_SLT[2:0] = 101	GPIOA0
SCL	GPA1_FUN_SLT[2:0] = 101	GPIOA1

**Timer0 Pin Setting Table:**

Timer0	Register Setting	Shared with GPIO
T0	GPA2_FUN_SLT[2:0] = 101	GPIOA2

**PWM0 Complex Function Setting Table:**

PWM0	Register Setting	Shared with GPIO
PWM0A	GPB3_FUN_SLT[2:0] = 011	GPIOB3
PWM0B	GPA4_FUN_SLT[1:0] = 011	GPIOA4
PWM0C	GPA0_FUN_SLT[1:0] = 011	GPIOA0
PWM0D	GPB2_FUN_SLT[1:0] = 011	GPIOB2

**PWM1 Complex Function Setting Table:**

PWM1	Register Setting	Shared with GPIO
PWM1A	GPB5_FUN_SLT[2:0] = 011	GPIOB5
PWM1B	GPA5_FUN_SLT[2:0] = 011	GPIOA5
PWM1C	GPA2_FUN_SLT[1:0] = 011	GPIOA2
PWM1D	GPB4_FUN_SLT[2:0] = 011	GPIOB4

**8052 Port 0 Complex Function Setting Table:**

8052 Port 0.x	Register Setting	Shared with GPIO
P0.0	GPA5_FUN_SLT[2:0] = 101	GPIOA5
P0.1	GPA4_FUN_SLT[2:0] = 101	GPIOA4
P0.2	GPB5_FUN_SLT[2:0] = 101	GPIOB5
P0.3	GPB4_FUN_SLT[2:0] = 101	GPIOB4
P0.4	GPC0_FUN_SLT[2:0] = 101	GPIOC0
P0.5	GPC1_FUN_SLT[2:0] = 101	GPIOC1
P0.6	GPC2_FUN_SLT[2:0] = 101	GPIOC2
P0.7	GPC3_FUN_SLT[2:0] = 101	GPIOC3

**Note: While using 8052 port (P0.x) or UART, please set the mapping GPIOx\_TYP as open drain, and add external pull-high resistor.**

### 6.3 Interrupt

The WT51F108S/104S provides eight 8052 Interrupt sources: four 8052 External Interrupts (INT0, INT1, INT2, INT3), three Timer/Counter Interrupts (TF0, TF1, TF2), and one UART Interrupt (RI0/TI0).

Each of these interrupt sources has its own enable control bit, and can be individually enabled or disabled by setting or clearing the corresponding bit in the Special Function Register IE0 or XICON.

When an interrupt is generated, CPU will jump to interrupt vector from service routine as listed below. If multiple requests of different priority levels are received simultaneously, the request of higher priority level is serviced, and then returned to service routine through RETI instruction. If interrupt flag bit is set, CPU will enter the Interrupt processing again.

**Interrupt Vector Table of 8052 & Priority Level Structure:**

Keil C Interrupt Number	Interrupt sources	Vector Address	Priority Level (default)	Interrupt Enable Register
0	8052 external interrupt 0	03H	1	IE.0 (EX0)
1	Timer/Counter 0 interrupt	0BH	2	IE.1 (ET0)
2	8052 external interrupt 1	13H	3	IE.2 (EX1)
4	Serial port 0 interrupt (UART0)	23H	5	IE.4 (ES)
7	8052 external interrupt 2	3BH	7	XICON.2 (EX2)
8	8052 external interrupt 3	43H	8	XICON.6 (EX3)

#### Interrupt Enable Register 0

**IE (8052 interrupt enable register, including INT0/INT1) Address: A8H**

**Reset Value: 00h**

7	6	5	4	3	2	1	0
EA	-	-	ES	-	EX1	ET0	EX0

Bit Number	Bit Mnemonic	Description
7	EA	1: Enable all interrupt function 0: Disable all interrupt function
6	-	Must be set as 0
5	-	Must be set as 0
4	ES	1: Enable UART 0 interrupt 0: Disable UART 0 interrupt
3	-	Must be set as 0
2	EX1	1: Enable 8052 external interrupt 1 interrupt 0: Disable 8052 external interrupt 1 interrupt
1	ET0	1: Enable Timer/Counter 0 interrupt 0: Disable Timer/Counter 0 interrupt

Bit Number	Bit Mnemonic	Description
0	EX0	1: Enable 8052 external interrupt 0 interrupt 0: Disable 8052 external interrupt 0 interrupt

**Interrupt Enable Register 1**
**XICON (8052 interrupt enable register, including INT2/INT3)) Address: C0H**
**Reset Value: 00h**

7	6	5	4	3	2	1	0
PX3	EX3	IE3	-	PX2	EX2	IE2	-

Bit Number	Bit Mnemonic	Description
7	PX3	Define the interrupt priority of external interrupt 3 1: INT3 has the higher priority 0: INT3 has no higher priority
6	EX3	1: Enable external interrupt 3 interrupt 0: Disable external interrupt 3 interrupt
5	IE3	If CPU detects external interrupt 3 interrupt, IE3 will be cleared by hardware 1: Has external interrupt 3 request 0: No external interrupt 3 request
4	Reserved	-
3	PX2	Define the interrupt priority of external interrupt 2 1: INT2 has the higher priority 0: INT2 has no higher priority
2	EX2	1: Enable external interrupt 2 interrupt 0: Disable external interrupt 2 interrupt
1	IE2	If CPU detects external interrupt 2 interrupt, IE2 will be cleared by hardware 1: Has external interrupt 2 request 0: No external interrupt 2 request
0	Reserved	-

**-: unimplemented.**
**Interrupt priority register**
**IP (8052 interrupt priority register) Address: B8H**
**Reset Value: 00h**

7	6	5	4	3	2	1	0
-	-	-	PS	-	PX1	PT0	PX0

Bit Number	Bit Mnemonic	Description
7	Reserved	-
6	-	Must be set as 0
5	-	Must be set as 0
4	PS	Define the interrupt priority of UART 0 1: Has the higher priority

Copyright© 2016 Weltrend Semiconductor, Inc. All Rights Reserved.

Weltrend reserves right to modify all information contained in this document without notice.

Bit Number	Bit Mnemonic	Description
		0: Has the lower priority
3	-	Must be set as 0
2	PX1	Define the interrupt priority of external interrupt 1 1: Has the higher priority 0: Has the lower priority
1	PT0	Define the interrupt priority of Timer/Counter 0 1: Has the higher priority 0: Has the lower priority
0	PX0	Define the interrupt priority of external interrupt 0 1: Has the higher priority 0: Has the lower priority

-: unimplemented.

As illustrated below, if not set the priority level in Interrupt Priority Register (IP), the priority level of interrupt will be: **INT0 > T0 > INT1 > UART0 > INT2 > INT3**.

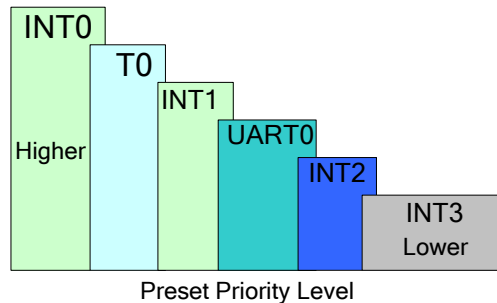

If the higher priority is assigned to any one of the interrupts, such as set PT1 = 1, then the priority level will be: **INT1 > INT0 > T0 > UART0 > INT2 > INT3**.

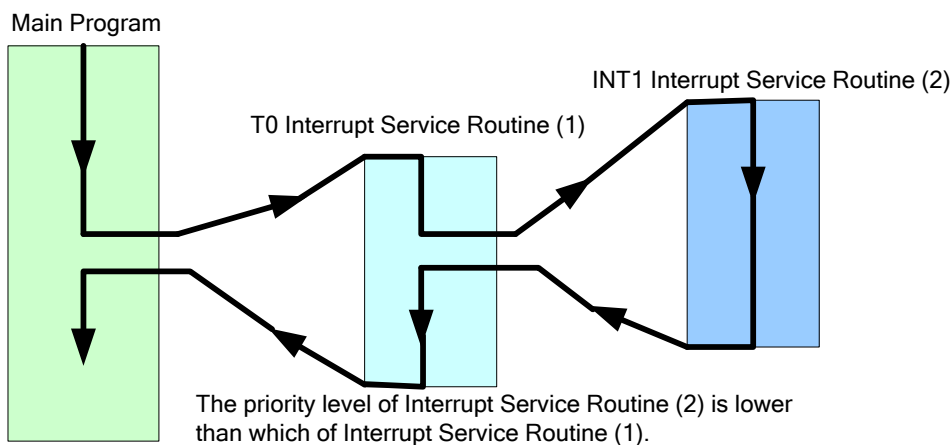

If PT1 = 0 and PX1 = 1, then the priority level will be: **T0 > INT1 > INT0 > UART0 > INT2 > INT3**, and so on. The figure below illustrated the executing procedures under different priority levels.

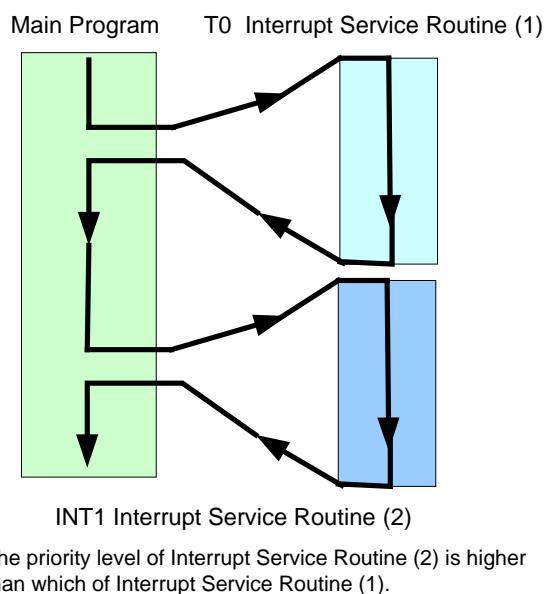



### 6.3.1 8052 External Interrupt 0/1/2

The WT51F108S/104S supports six peripheral interrupt sources which are derived from 8052 external interrupt 0/1/2, as described below.

1. I<sup>2</sup>C interrupt
2. ADC interrupt
3. Low Voltage Detection (LVD) interrupt
4. Watch Timer interrupt
5. Enhanced Timer/Counter interrupt
6. General-purpose I/O port input triggered interrupt

The figure below shows the interrupt sources of 8052 external interrupt 0/1/2:

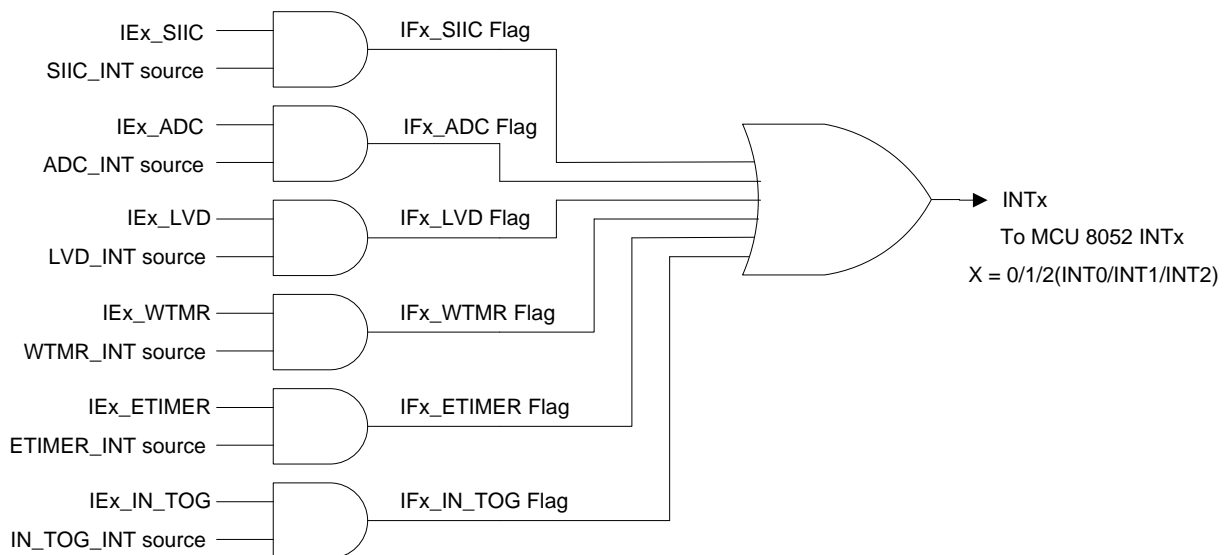

### 6.3.2 8052 External Interrupt 3

WT51F108S/104S contains eight External Interrupt Request input pins. An interrupt is generated by using 8052 External Interrupt Vector 3, as illustrated below (refer to section 6.5 for more details).

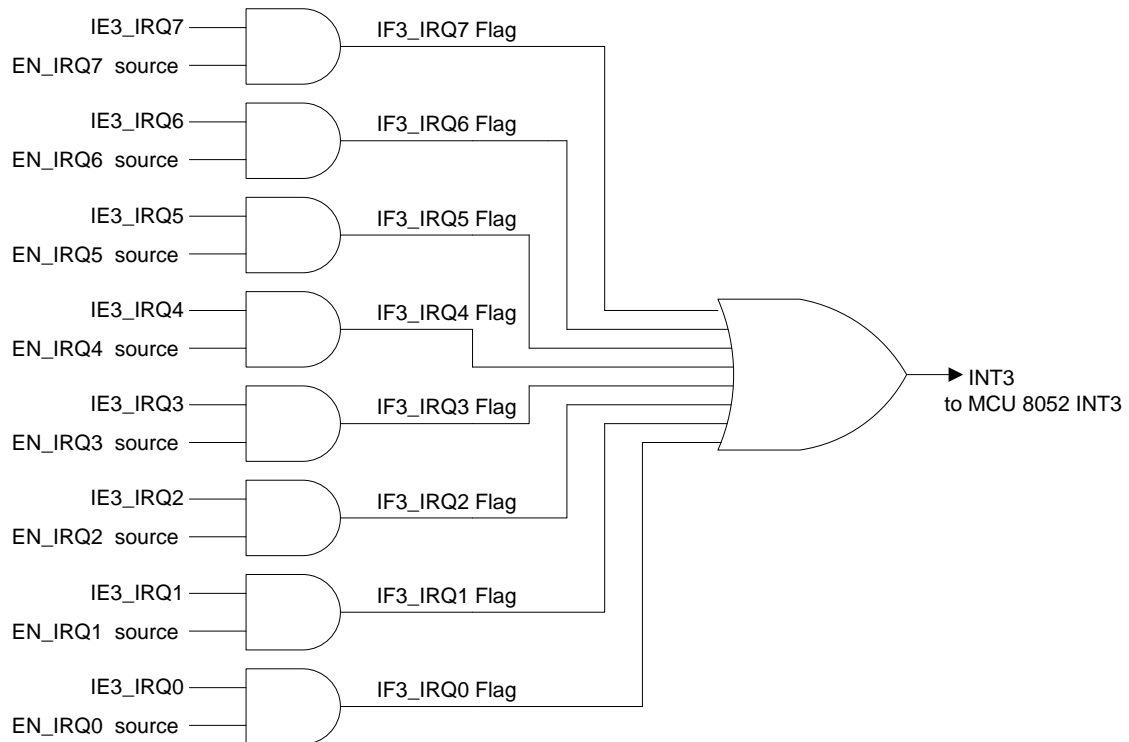

**8052 External Interrupt 0 Control Register IE0\_CTL (XFR: 0x30)**
**Reset Value: 00h**

Bit	Bit 7	Bit 6	Bit 5	Bit 4	Bit 3	Bit 2	Bit 1	Bit 0
Status	-	R/W	R/W	-	R/W	R/W	R/W	R/W
Name	Reserved	IE0_SI <sup>2</sup> C	IE0_ADC	Reserved	IE0_LVD	IE0_WTMR	IE0_ETIMER	IE0_IN_TOG

Bit Number	Bit Mnemonic	Description
7	Reserved	Must be set as 0
6	IE0_SI <sup>2</sup> C	1: Enable Slave I <sup>2</sup> C Interrupt generated by INT0 0: Disable Slave I <sup>2</sup> C Interrupt generated by INT0
5	IE0_ADC	1: Enable ADC Interrupt generated by INT0 0: Disable ADC Interrupt generated by INT0
4	Reserved	Must be set as 0
3	IE0_LVD	1: Enable LVD Interrupt generated by INT0 0: Disable LVD Interrupt generated by INT0
2	IE0_WTMR	1: Enable Watch Timer Interrupt generated by INT0 0: Disable Watch Timer Interrupt generated by INT0
1	IE0_ETIMER	1: Enable Enhanced Timer Interrupt generated by INT0 0: Disable Enhanced Timer Interrupt generated by INT0
0	IE0_IN_TOG	1: Enable All-Input Toggle Interrupt generated by INT0 0: Disable All-Input Toggle Interrupt generated by INT0

**8052 External Interrupt 1 Control Register IE1\_CTL (XFR: 0x31)**
**Reset Value: 00h**

Bit	Bit 7	Bit 6	Bit 5	Bit 4	Bit 3	Bit 2	Bit 1	Bit 0
Status	-	R/W	R/W	-	R/W	R/W	R/W	R/W
Name	Reserved	IE1_SI <sup>2</sup> C	IE1_ADC	Reserved	IE1_LVD	IE1_WTMR	IE1_ETIMER	IE1_IN_TOG

Bit Number	Bit Mnemonic	Description
7	Reserved	Must be set as 0
6	IE1_SI <sup>2</sup> C	1: Enable Slave I <sup>2</sup> C Interrupt generated by INT1 0: Disable Slave I <sup>2</sup> C Interrupt generated by INT1
5	IE1_ADC	1: Enable ADC Interrupt generated by INT1 0: Disable ADC Interrupt generated by INT1
4	Reserved	Must be set as 0
3	IE1_LVD	1: Enable LVD Interrupt generated by INT1 0: Disable LVD Interrupt generated by INT1
2	IE1_WTMR	1: Enable Watch Timer Interrupt generated by INT1 0: Disable Watch Timer Interrupt generated by INT1
1	IE1_ETIMER	1: Enable Enhanced Timer Interrupt generated by INT1 0: Disable Enhanced Timer Interrupt generated by INT1
0	IE1_IN_TOG	1: Enable All-Input Toggle Interrupt generated by INT1 0: Disable All-Input Toggle Interrupt generated by INT1

**8052 External Interrupt 2 Control Register IE2\_CTL (XFR: 0x32)**
**Reset Value: 00h**

Bit	Bit 7	Bit 6	Bit 5	Bit 4	Bit 3	Bit 2	Bit 1	Bit 0
Status	-	R/W	R/W	-	R/W	R/W	R/W	R/W
Name	Reserved	IE2_SI <sup>2</sup> C	IE2_ADC	Reserved	IE2_LVD	IE2_WTMR	IE2_ETIMER	IE2_IN_TOG

Bit Number	Bit Mnemonic	Description
7	Reserved	Must be set as 0
6	IE2_SI <sup>2</sup> C	1: Enable Slave I <sup>2</sup> C Interrupt generated by INT2 0: Disable Slave I <sup>2</sup> C Interrupt generated by INT2
5	IE2_ADC	1: Enable ADC Interrupt generated by INT2 0: Disable ADC Interrupt generated by INT2
4	Reserved	Must be set as 0
3	IE2_LVD	1: Enable LVD Interrupt generated by INT2 0: Disable LVD Interrupt generated by INT2
2	IE2_WTMR	1: Enable Watch Timer Interrupt generated by INT2 0: Disable Watch Timer Interrupt generated by INT2
1	IE2_ETIMER	1: Enable Enhanced Timer Interrupt generated by INT2 0: Disable Enhanced Timer Interrupt generated by INT2
0	IE2_IN_TOG	1: Enable All-Input Toggle Interrupt generated by INT2 0: Disable All-Input Toggle Interrupt generated by INT2

**8052 External Interrupt 3 Control Low Bytes Register INT3\_IRQ[7:0] (XFR: 0x34)**
**Reset Value: 00h**

Bit	Bit 7	Bit 6	Bit 5	Bit 4	Bit 3	Bit 2	Bit 1	Bit 0
Status	R/W	R/W	R/W	R/W	R/W	R/W	R/W	R/W
Name	IE3_IRQ[7:0]							

Bit Number	Bit Mnemonic	Description
7	IE3_IRQ7	1: Enable IRQ7 Interrupt generated by INT3 0: Disable IRQ7 Interrupt generated by INT3
6	IE3_IRQ6	1: Enable IRQ6 Interrupt generated by INT3 0: Disable IRQ6 Interrupt generated by INT3
5	IE3_IRQ5	1: Enable IRQ5 Interrupt generated by INT3 0: Disable IRQ5 Interrupt generated by INT3
4	IE3_IRQ4	1: Enable IRQ4 Interrupt generated by INT3 0: Disable IRQ4 Interrupt generated by INT3
3	IE3_IRQ3	1: Enable IRQ3 Interrupt generated by INT3 0: Disable IRQ3 Interrupt generated by INT3
2	IE3_IRQ2	1: Enable IRQ2 Interrupt generated by INT3 0: Disable IRQ2 Interrupt generated by INT3
1	IE3_IRQ1	1: Enable IRQ1 Interrupt generated by INT3 0: Disable IRQ1 Interrupt generated by INT3
0	IE3_IRQ0	1: Enable IRQ0 Interrupt generated by INT3 0: Disable IRQ0 Interrupt generated by INT3

**8052 External Interrupt 0 (INT0) Flag Register IF0\_FLAG (XFR: 0x35)**
**Reset Value: 00h**

Bit	Bit 7	Bit 6	Bit 5	Bit 4	Bit 3	Bit 2	Bit 1	Bit 0
Status	-	R	R	-	R	R	R	R
Name	Reserved	IF0_SI <sup>2</sup> C	IF0_ADC	Reserved	IF0_LVD	IF0_WTMR	IF0_ETIMER	IF0_IN_TOG

Bit Number	Bit Mnemonic	Description
7	Reserved	
6	IF0_SI <sup>2</sup> C	1: Slave I <sup>2</sup> C Interrupt Event Flag be set, Slave I <sup>2</sup> C Interrupt Flag Clear, refer to section 6.10 XFR[0xA0]
5	IF0_ADC	1: ADC Interrupt Event Flag be set, will be cleared automatically after ADC conversion
4	Reserved	-
3	IF0_LVD	1: LVD Interrupt Event Flag be set, LVD Interrupt Flag Clear, refer to section 6.16 XFR[0x03]
2	IF0_WTMR	1: Watch Timer Interrupt Event Flag be set, Watch Timer Interrupt Flag Clear, refer to section 6.9 XFR[0x7C]
1	IF0_ETIMER	1: Enhanced Timer Interrupt Event Flag be set, Enhanced Timer Interrupt Flag Clear, refer to section 6.11 XFR[0xB2]
0	IF0_IN_TOG	1: All-Input Toggle Interrupt Event Flag be set, Input Toggle Interrupt Clear, refer to section 6.7 XFR[0x6A]

**8052 External Interrupt 1 (INT1) Flag Register IF1\_FLAG (XFR: 0x36)**
**Reset Value: 00h**

Bit	Bit 7	Bit 6	Bit 5	Bit 4	Bit 3	Bit 2	Bit 1	Bit 0
Status	-	R	R	-	R	R	R	R
Name	Reserved	IF1_SI <sup>2</sup> C	IF1_ADC	Reserved	IF1_LVD	IF1_WTMR	IF1_ETIMER	IF1_IN_TOG

Bit Number	Bit Mnemonic	Description
7	Reserved	-
6	IF1_SI <sup>2</sup> C	1: Slave I <sup>2</sup> C Interrupt Event Flag be set, Slave I <sup>2</sup> C Interrupt Flag Clear, refer to section 6.10 XFR[0xA0]
5	IF1_ADC	1: ADC Interrupt Event Flag be set, will be cleared automatically after ADC conversion
4	Reserved	-
3	IF1_LVD	1: LVD Interrupt Event Flag be set, LVD Interrupt Flag Clear, refer to section 6.16 XFR[0x03]
2	IF1_WTMR	1: Watch Timer Interrupt Event Flag be set, Watch Timer Interrupt Flag Clear, refer to section 6.9 XFR[0x7C]
1	IF1_ETIMER	1: Enhanced Timer Interrupt Event Flag be set, Enhanced Timer Interrupt Flag Clear, refer to section 6.11 XFR[0xB2]
0	IF1_IN_TOG	1: All-Input Toggle Interrupt Event Flag be set, Input Toggle Interrupt Flag Clear, refer to section 6.7 XFR[0x6A]

**8052 External Interrupt 2 (INT2) Flag Register IF2\_FLAG (XFR: 0x37)**
**Reset Value: 00h**

Bit	Bit 7	Bit 6	Bit 5	Bit 4	Bit 3	Bit 2	Bit 1	Bit 0
Status	-	R	R	-	R	R	R	R
Name	Reserved	IF2_SI <sup>2</sup> C	IF2_ADC	Reserved	IF2_LVD	IF2_WTMR	IF2_ETIMER	IF2_IN_TOG

Bit Number	Bit Mnemonic	Description
7	Reserved	
6	IF2_SI <sup>2</sup> C	1: Slave I <sup>2</sup> C Interrupt Event Flag be set, Slave I <sup>2</sup> C Interrupt Flag Clear, refer to section 6.10 XFR[0xA0]
5	IF2_ADC	1: ADC Interrupt Event Flag be set, will be cleared automatically after ADC conversion
4	Reserved	
3	IF2_LVD	1: LVD Interrupt Event Flag be set, LVD Interrupt Flag Clear, refer to section 6.16 XFR[0x03]
2	IF2_WTMR	1: Watch Timer Interrupt Event Flag be set, Watch Timer Interrupt Flag Clear, refer to section 6.9 XFR[0x7C]
1	IF2_ETIMER	1: Enhanced Timer Interrupt Event Flag be set, Enhanced Timer Interrupt Flag Clear, refer to section 6.11 XFR[0xB2]
0	IF2_IN_TOG	1: All-Input Toggle Interrupt Event Flag be set, Input Toggle Interrupt Flag Clear, refer to section 6.7 XFR[0x6A]

**8052 External Interrupt 3 (INT3) Flag Register IF3\_IRQ[7:0] (XFR: 0x39)**
**Reset Value: 00h**

Bit	Bit 7	Bit 6	Bit 5	Bit 4	Bit 3	Bit 2	Bit 1	Bit 0
Status	R	R	R	R	R	R	R	R
Name	IF3_IRQ[7:0]							

Bit Number	Bit Mnemonic	Description
7	IF3_IRQ7	1: IRQ7 Interrupt Event Flag be set, IRQ Interrupt Flag Clear, refer to section 6.5 XFR[0x45]
6	IF3_IRQ6	1: IRQ6 Interrupt Event Flag be set, IRQ Interrupt Flag Clear, refer to section 6.5 XFR[0x45]
5	IF3_IRQ5	1: IRQ5 Interrupt Event Flag be set, IRQ Interrupt Flag Clear, refer to section 6.5 XFR[0x45]
4	IF3_IRQ4	1: IRQ4 Interrupt Event Flag be set, IRQ Interrupt Flag Clear, refer to section 6.5 XFR[0x45]
3	IF3_IRQ3	1: IRQ3 Interrupt Event Flag be set, IRQ Interrupt Flag Clear, refer to section 6.5 XFR[0x45]
2	IF3_IRQ2	1: IRQ2 Interrupt Event Flag be set, IRQ Interrupt Flag Clear, refer to

Bit Number	Bit Mnemonic	Description
		section 6.5 XFR[0x45]
1	IF3_IRQ1	1: IRQ1 Interrupt Event Flag be set, IRQ Interrupt Flag Clear, refer to section 6.5 XFR[0x45]
0	IF3_IRQ0	1: IRQ0 Interrupt Event Flag be set, IRQ Interrupt Flag Clear, refer to section 6.5 XFR[0x45]

## 6.4 Universal Asynchronous Receiver-Transmitter (UART)

The WT51F108S/104S contains one Universal Asynchronous Receiver-Transmitter (UART0).

As a standard UART of 8052, the Baud rate is selected by the Serial Baud rate Generator in SFR.

On Transmit and Receive, the SFR SBUFx uses two separate registers: a transmit buffer and a receive buffer register.

Transmitting data: Writing to SBUF0 register and loads these data in serial output buffer, and starts transmitting.

Receiving data: Reading SBUF0 register and reading the serial receive buffer. The serial port can transmit and receive simultaneously. It is also one byte receive-buffered, meaning it can commence reception of a second byte before a previously received byte has been read from the receive register to prevent data loss.

### The peripheral registers of UART:

SFR Name	Address	Description
PCON	87H	8052 power control register
SCON0	98H	Serial Port 0, Control Register
SBUF0	99H	Serial Port 0, Data Buffer
SBRG0H	9AH	Serial Baud rate Generator 0, high byte
SBRG0L	9BH	Serial Baud rate Generator 0, low byte

### UART0 Peripheral Registers

#### PCON (Power control register) Address: 87H

7	6	5	4	3	2	1	0
SMOD1	-	-	-	-	-	-	-

SMOD1: UART0 dual rate bit.

-: unimplemented.

#### SBUF0 (8052 UART0 buffer) Address: 99H

7	6	5	4	3	2	1	0
SBUF0.7	SBUF0.6	SBUF0.5	SBUF0.4	SBUF0.3	SBUF0.2	SBUF0.1	SBUF0.0

The Serial Data Buffer of UART0. It is used to hold the bytes to be received or the bytes to be transmitted from UART0.

#### SBRG0H: Address: 9Ah

7	6	5	4	3	2	1	0
SBRG_EN	BRG_M[10]	BRG_M[9]	BRG_M[8]	BRG_M[7]	BRG_M[6]	BRG_M[5]	BRG_M[4]

Used to configure the Baud rate of UART0 and it must be accessed together with SBRG0L.



**SBRG0L: Address: 9Bh**

7	6	5	4	3	2	1	0
BRG_M[3]	BRG_M[2]	BRG_M[1]	BRG_M[0]	BRG_F[3]	BRG_F[2]	BRG_F[1]	BRG_F[0]

Used to configure the Baud rate of UART0 and it must be accessed together with SBRG0H.

**SCON0 (8052 UART0 control register) Address: 98H**

7	6	5	4	3	2	1	0
SM0_1	SM0_2	SM0_3	REN_0	TB8_0	RB8_0	TI_0	RI_0

Bit Number	Bit Mnemonic	Description
7-6	SM0_1, SM0_2	UART0 mode selection 00: Mode 0 01: Mode 1 10: Mode 2 11: Mode 3
5	SM0_3	Multi-processor Communication Enable bit In Mode 0, if SM0_3 = 0, the multi-processor communication function is disabled. In Mode 1, 2, or 3, if SM0_3 = 1, the multi-processor communication function is enabled.
4	REN_0	UART Receive Enable bit must be cleared by software. REN_0 = 1, receive starts. REN_0 = 0, receive stops.
3	TB8_0	The 9 <sup>th</sup> transmit bit in Mode 2 or Mode 3, can be set or cleared by software.
2	RB8_0	In Mode 0, this bit is invalid. In Mode 1, this bit is Stop bit if SM0_3 = 0 In Mode 2 or 3, the 9 <sup>th</sup> data bit that was received.
1	TI_0	Transmit Interrupt Flag. When an interrupt is complete, this bit will not be restored to "0", and it must be cleared by software. In Mode 0, this bit is set by hardware at the end of the 8 <sup>th</sup> bit, and meantime it can commence a TI_0 interrupt. In Mode 1, 2, or 3, this bit is set by hardware at the end of transmitting Stop bit, and meantime it can commence a TI_0 interrupt.
0	RI_0	Receive Interrupt Flag. When an interrupt is complete, this bit will not be restored to "0", and it must be cleared by software. In Mode 0, this bit is set by hardware at the end of the 8 <sup>th</sup> bit, and meantime it can commence a RI_0 interrupt. In Mode 1, 2, or 3, this bit is set by hardware at the end of transmitting Stop bit, and meantime it can commence a RI_0 interrupt.

The Serial Interface 0 can operate in four modes, as described below.

SM0_1	SM0_2	Mode	Function	Baud Rate
0	0	0	Shift Register	Fosc/12
0	1	1	8-bit UART	Software programmed
1	0	2	8-bit UART	Fosc/32 or Fosc/64
1	1	3	9-bit UART	Software programmed

\*Fosc = MCU clock

### Mode 0

In Mode 0, the Baud rate of Shift transmission register is fixed at 1/12 of the oscillator frequency ( $f_{OSC}/12$ ). At 12 MHz, the Baud rate is 1Mbps. In this mode, no matter on receive or transmit data, Rx0 of CPUs connects each other worked as a serial data bus and Tx0 connects each other worked as a Shift pulse. On Receive, Tx0 pin sent out the shift pulse, and the serial data is received by Rx0 pin; On Transmit, it is also based on the shift pulse sent by Tx0 pin, and sent the serial data by Rx0 pin.

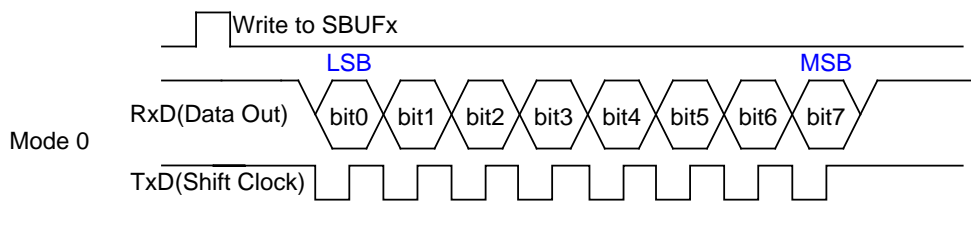

### Mode 1

Mode 1 may have a variable Baud rate for serial data transmit, and the Baud rate can be controlled by Timer 1. (If UART1 is supported, Timer 2 is also available for controlling the Baud rate). WT51F108S/104S does not support using Timer 1 to control Baud Rate.

In this mode, the Rx0 pin of WT51F108S/104S connects to the destination TxD pin, and the Tx0 pin of WT51F108S/104S connects to the destination RxD pin.

10 bits are length of transmitted or received: a Start bit, 8 data bits, and a Stop bit. The first bit is the low level start bit (0), followed by the 8 data bits (LSB first, starts from bit 0), then the high level stop bit (1) after bit 7 (MSB).



**Mode 2**

Mode 2 operates at  $f_{OSC}/32$  (SMOD = 1) or  $f_{OSC}/64$  (SMOD = 0) for serial data transmission. As for the wire connection, Rx0 pin of WT51F108S/104S connects to destination TxD pin and Tx0 pin of WT51F108S/104S connects to destination RxD pin. 11 bits are length of transmitted or received: a Start bit, 8 data bits, a Parity bit, and 1 Stop bit. The first bit is the low level start bit (0), followed by the 8 data bits (LSB first, starts from bit 0), then the Parity bit after bit 7, and finally the high level stop bit.

On Transmit, TB8\_0 in SCON0 is the 9<sup>th</sup> data bit. The TB8\_0 in SCON0 will transmit the 9<sup>th</sup> data bit; On Receive, the RB8\_0 in SCON0 will receive the 9<sup>th</sup> data bit.

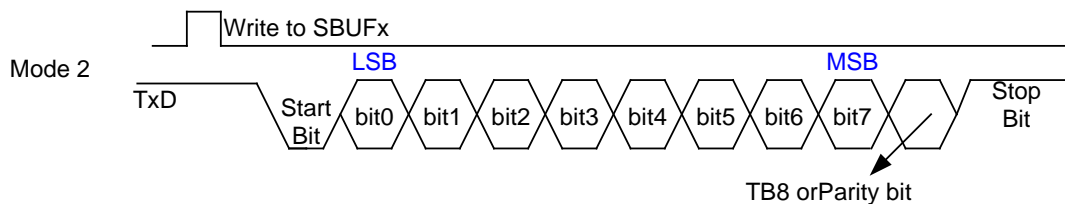

**Mode 3**

The Baud rate in mode 3 is variable for serial data transmission, and it is controlled by Timer 1 (If UART1 is supported, Timer 2 is allowed to control the Baud rate). The operation in Mode 3 is the same as Mode 2.

**Serial Baud rate of UART0:**

SBRG_EN (SBRG0H.7)	SMOD1 (PCON.7)	Baud Rate for UART0
0	0	$\frac{1}{32} \times \frac{f_{osc}}{12 \times (256 - TH1)}$
0	1	$\frac{1}{16} \times \frac{f_{osc}}{12 \times (256 - TH1)}$
1	0	$\frac{f_{osc}}{32 * (BRG\_M[10:0] + \frac{BRG\_F[3:0]}{16})}$
1	1	$\frac{f_{osc}}{16 * (BRG\_M[10:0] + \frac{BRG\_F[3:0]}{16})}$

If SBRG\_EN (SBRG0H.7) = 1 & SMOD1(PCON.7) = 1

$$\text{UART0 Baud rate} = \frac{f_{osc}}{16 * (BRG\_M[10:0] + \frac{BRG\_F[3:0]}{16})}$$

**Baud rate supporting table:**

Bits/sec	12 MHz				
	Baud Rate Register	BRG_M	BRG_F	Actual	Error
600	1250	1250	0	600	0.0%
1200	625	625	0	1200	0.0%
2400	312.5	312	8	2400	0.0%
4800	156.25	156	4	4800	0.0%
9600	78.125	78	2	9600	0.0%
14400	52.083	52	1	14405	0.04%
19200	39.0625	39	1	19200	0.0%
38400	19.531	19	8	38461	0.16%
57600	13	13	0	57692	0.16%
115200	6.5	6	8	115384	0.16%
230400	3.25	3	4	230769	0.16%

WT51F108S/104S supports one UART; the UART0 can select different RX0/TX0 path to prevent the pin being occupied.

UART	Register Setting	Shared with GPIO
RX0A	GPB5_FUN_SLT[2:0] = 010	GPIOB5
TX0A	GPB4_FUN_SLT[2:0] = 010	GPIOB4
RX0B	GPA1_FUN_SLT[2:0] = 100	GPIOA1
TX0B	GPA0_FUN_SLT[2:0] = 100	GPIOA0

## 6.5 External Interrupt Request (IRQ)

- Supports eight input Interrupts and built-in digital Filter. (The clock source of digital filter is internal oscillator 12 MHz)
- Supports single-side positive edge-triggered, negative edge-triggered, or positive edge and negative edge triggered simultaneously
- It can work with PWM, applied on motor RPM (Revolutions Per Minute) Control. Please refer to the table below.

**External Interrupt Request (IRQ) & PWM0 mapping table:**

External Interrupt Request (IRQ) pin	PWM0	Output pin
IRQ0	Path C	GPIOA0
IRQ5	Path D	GPIOB2

**External Interrupt Request (IRQ) & PWM1 mapping table:**

External Interrupt Request (IRQ) pin	PWM1	Output pin
IRQ3	Path A	GPIOB5
IRQ2	Path C	GPIOA2

**Single side triggered:**

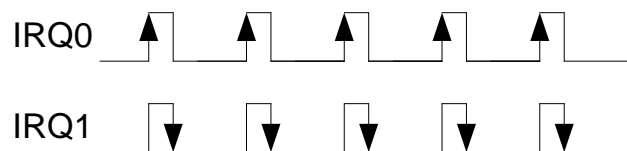

**Bidirectional triggered:**



**External Interrupt Request (IRQ) Control Register EN\_IRQ [7:0] (XFR: 0x41)**
**Reset Value: 00h**

Bit	Bit 7	Bit 6	Bit 5	Bit 4	Bit 3	Bit 2	Bit 1	Bit 0
Status	R/W	R/W	R/W	R/W	R/W	R/W	R/W	R/W
Name	EN_IRQ[7:0]							

Bit Number	Bit Mnemonic	Description
7-0	EN_IRQ[7:0]	External Interrupt Request Enable setting. Each bit is corresponded to the related IRQ pin. 1: Enable the External Interrupt Request of the corresponding pins. 0: Disable the External Interrupt Request of the corresponding pins.

**External Interrupt Request (IRQ) Status Register EVT\_IRQ [7:0] (XFR: 0x43)**
**Reset Value: 00h**

Bit	Bit 7	Bit 6	Bit 5	Bit 4	Bit 3	Bit 2	Bit 1	Bit 0
Status	R	R	R	R	R	R	R	R
Name	EVT_IRQ[7:0]							

Bit Number	Bit Mnemonic	Description
7-0	EVT_IRQ[7:0]	External Interrupt Request Status. Each bit is corresponded to the related IRQ status. 1: An interrupt trigger occurred in the corresponding pins. 0: An interrupt trigger not occurred in the corresponding pins.

**External Interrupt Request (IRQ) Clear Register CLR\_IRQ [7:0] (XFR: 0x45)**
**Reset Value: 00h**

Bit	Bit 7	Bit 6	Bit 5	Bit 4	Bit 3	Bit 2	Bit 1	Bit 0
Status	W	W	W	W	W	W	W	W
Name	CLR_IRQ[7:0]							

Bit Number	Bit Mnemonic	Description
7-0	CLR_IRQ[7:0]	External Interrupt Request Clear 1: Writing one to the corresponding bits can clear the interrupt status 0: No action

**External Interrupt Request (IRQ) Bi-directional Trigger Register IRQ\_CHG [7:0] (XFR: 0x47) Reset Value: 00h**

Bit	Bit 7	Bit 6	Bit 5	Bit 4	Bit 3	Bit 2	Bit 1	Bit 0
Status	R/W	R/W	R/W	R/W	R/W	R/W	R/W	R/W
Name	IRQ_CHG[7:0]							

Bit Number	Bit Mnemonic	Description
7-0	IRQ_CHG[7:0]	External Interrupt Request Trigger setting

Bit Number	Bit Mnemonic	Description
		1: Bi-directional triggered 0: Single-side triggered (work together with IRQ_EDGE[7:0] to set positive or negative triggered)

**External Interrupt Request (IRQ) Trigger Edge Register IRQ\_EDGE [7:0] (XFR: 0x49)      Reset Value: 00h**

Bit	Bit 7	Bit 6	Bit 5	Bit 4	Bit 3	Bit 2	Bit 1	Bit 0
Status	R/W	R/W	R/W	R/W	R/W	R/W	R/W	R/W
Name	IRQ_EDGE[7:0]							

Bit Number	Bit Mnemonic	Description
7-0	IRQ_EDGE[7:0]	External Interrupt Request Trigger Edge setting 1: negative edge trigger 0: positive edge trigger

## 6.6 Pulse Width Modulation (PWM)

WT51F108S/104S provides two 16-bit precise Pulse Width Modulation modules to generate periods and Duty cycles.

- Output Frequency is 65535 levels; frequency range: 6 MHz ~ 183.1 Hz (at IRC 12 MHz)
- The resolutions of Duty and period and source clock are closely related to each other.

$$\boxed{\text{Source clock}} = 2^{\boxed{\text{Duty resolution}}} \times \boxed{\text{Period}}$$

For example, if Source clock is IRC 12 MHz, Duty Resolution is 10 bit, and then the period range is limited within 11.7 kHz.

- Output type: push pull or open drain, can be configured by GPIOx\_TYP[x] register (please refer to the table below)
- Pulse Width output will trigger external interrupt request (IRQ) to generate an interrupt, and which is used to calculate the numbers of PWM output or generate Period INT/Duty INT for Motor control application
- PWM0 & PWM1 can select different output pins by the Complex Function Setting Register for more applications

PWM0 can select four pins by General-purpose I/O port x Complex Function Setting Register, and one pin is for output.

PWM0	Output pin	External Interrupt Request (IRQ) pin	General-purpose I/O Port x Complex Function Setting Register
Path A	GPIOB3	-	GPB3_FUN_SLT[2:0] = 011
Path B	GPIOA4	-	GPA4_FUN_SLT[2:0] = 011
Path C	GPIOA0	IRQ0	GPA0_FUN_SLT[2:0] = 011
Path D	GPIOB2	IRQ5	GPB2_FUN_SLT[2:0] = 011

PWM1 can select four pins by General-purpose I/O port x Complex Function Setting Register, and one pin is for output.

PWM1	Output pin	External Interrupt Request (IRQ) pin	General-purpose I/O Port x Complex Function Setting Register
Path A	GPIOB5	IRQ3	GPB5_FUN_SLT[2:0] = 011
Path B	GPIOA5	-	GPA5_FUN_SLT[2:0] = 011
Path C	GPIOA2	IRQ2	GPA2_FUN_SLT[2:0] = 011
Path D	GPIOB4	-	GPB4_FUN_SLT[2:0] = 011

For example, PWM0 outputs 5 pulses can be done by the positive-edge triggered of GPIOB3/IRQ10, after counting for 5 times, turning off PWM. Moreover, the period of PWM is able to calculate.



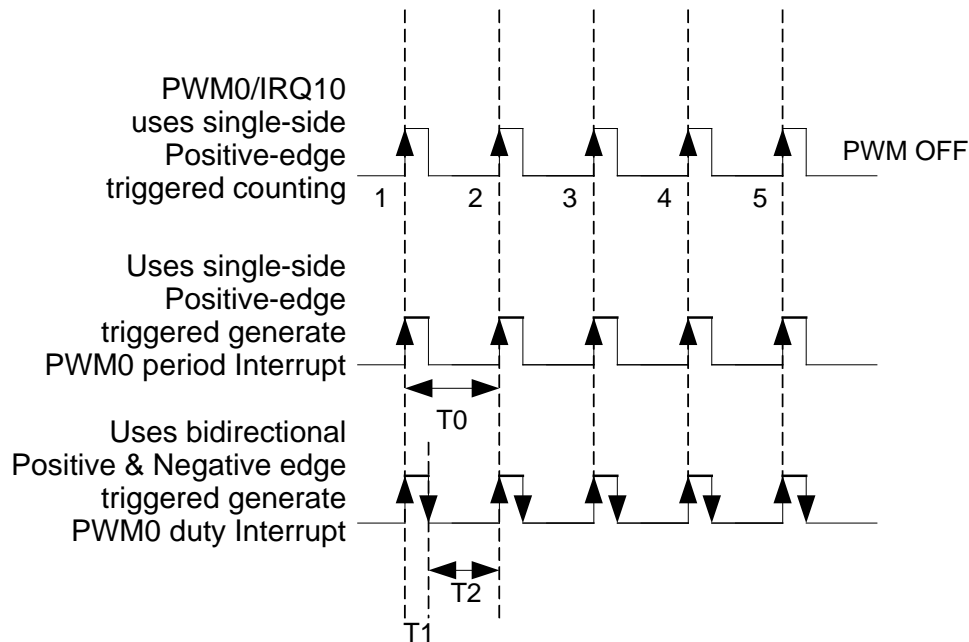

**PWM Control Register 0 PWM\_CTL (XFR: 0x50)**

**Reset Value: 00h**

Bit	Bit 7	Bit 6	Bit 5	Bit 4	Bit 3	Bit 2	Bit 1	Bit 0
Status	-	-	R/W	R/W	-	R/W	R/W	R/W
Name	Reserved		PWM_PLRTY[1:0]		Reserved	LBYTE_UPD_EN	PWM_EN[1:0]	

Bit Number	Bit Mnemonic	Description
7-6	Reserved	-
5-4	PWM_PLRTY[1:0]	Bit 5: 1: PWM1 negative edge output 0: PWM1 positive edge output Bit 4: 1: PWM0 negative edge output 0: PWM0 positive edge output
3	Reserved	-
2	LBYTE_UPD_EN	1: Enable updating PWM output while writing PWM period or Duty Cycle Control Low Bytes Register 0: Disable updating PWM output while writing PWM period or Duty Cycle Control Low Bytes Register
1	PWM_EN[1:0]	1: Enable PWM1 function 0: Disable PWM1 function
0		1: Enable PWM0 function 0: Disable PWM0 function

**-: unimplemented.**

**PWM0 Period Control High Bytes Register PWM0\_PRD[15:8] (XFR: 0x51)**
**Reset Value: 00h**

Bit	Bit 7	Bit 6	Bit 5	Bit 4	Bit 3	Bit 2	Bit 1	Bit 0
Status	R/W	R/W	R/W	R/W	R/W	R/W	R/W	R/W
Name	PWM0_PRD[15:8]							

Bit Number	Bit Mnemonic	Description
7-0	PWM0_PRD[15:8]	PWM0_PRD[15:8] sets the output period of PWM0, and which is paired with PWM0_PRD[7:0] to form a 16-bit of period control value. PWM0 period: SOURCE clock/ (PWM0_PRD[15:0]+1), source clock: 12/24 MHz IRC, DC ~ 24 MHz Crystal OSC. 32 kHz IRC and 32.768 kHz Crystal OSC.

**PWM0 Period Control Low Bytes Register PWM0\_PRD[7:0] (XFR: 0x52)**
**Reset Value: 01h**

Bit	Bit 7	Bit 6	Bit 5	Bit 4	Bit 3	Bit 2	Bit 1	Bit 0
Status	R/W	R/W	R/W	R/W	R/W	R/W	R/W	R/W
Name	PWM0_PRD[7:0]							

Bit Number	Bit Mnemonic	Description
7-0	PWM0_PRD[7:0]	PWM0_PRD[7:0] sets the output period of PWM0, and which is paired with PWM0_PRD[15:8] to form a 16-bit of period control value. PWM0 period: SOURCE clock/ (PWM0_PRD[15:0]+1), source clock: 12/24 MHz IRC, DC ~ 24 MHz Crystal OSC. 32 kHz IRC and 32.768 kHz Crystal OSC.

**PWM0 Duty Cycle Control High Bytes Register PWM0\_DUTY[15:8] (XFR: 0x53)**
**Reset Value: 00h**

Bit	Bit 7	Bit 6	Bit 5	Bit 4	Bit 3	Bit 2	Bit 1	Bit 0
Status	R/W	R/W	R/W	R/W	R/W	R/W	R/W	R/W
Name	PWM0_DUTY[15:8]							

Bit Number	Bit Mnemonic	Description
7-0	PWM0_DUTY[15:8]	Sets the duty cycle output of PWM0. PWM0_DUTY[15:8] sets the duty cycle of PWM0, and is paired with PWM0_DUTY[7:0] to form a 16-bit of duty cycle control value.

**Note: The maximum setting of Duty must be a reasonable value.**
**PWM0 Duty Cycle Control Low Bytes Register PWM0\_DUTY[7:0] (XFR: 0x54)**
**Reset Value: 00h**

Bit	Bit 7	Bit 6	Bit 5	Bit 4	Bit 3	Bit 2	Bit 1	Bit 0
Status	R/W	R/W	R/W	R/W	R/W	R/W	R/W	R/W
Name	PWM0_DUTY[7:0]							

Bit Number	Bit Mnemonic	Description
7-0	PWM0_DUTY[7:0]	Set the duty cycle output of PWM0 PWM0_DUTY[7:0] sets the duty cycle of PWM0, and is paired with PWM0_DUTY[15:8] to form a 16-bit of duty cycle control value.

**Note: The maximum setting of Duty must be a reasonable value.**

**PWM1 Period Control High Bytes Register PWM1\_PRD[15:8] (XFR: 0x55)**
**Reset Value: 00h**

Bit	Bit 7	Bit 6	Bit 5	Bit 4	Bit 3	Bit 2	Bit 1	Bit 0
Status	R/W	R/W	R/W	R/W	R/W	R/W	R/W	R/W
Name	PWM1_PRD[15:8]							

Bit Number	Bit Mnemonic	Description
7-0	PWM1_PRD[15:8]	PWM1_PRD[15:0] sets the output period of PWM1, and is paired with PWM1_PRD[7:0] to form a 16-bit of duty cycle control value. PWM1 period: SOURCE clock/ (PWM1_PRD[15:0]+1), source clock: 12/24 MHz IRC, DC ~ 24 MHz Crystal OSC. 32 kHz IRC and 32.768 kHz Crystal OSC.

**PWM1 Period Control Low Bytes Register PWM1\_PRD[7:0] (XFR: 0x56)**
**Reset Value: 01h**

Bit	Bit 7	Bit 6	Bit 5	Bit 4	Bit 3	Bit 2	Bit 1	Bit 0
Status	R/W	R/W	R/W	R/W	R/W	R/W	R/W	R/W
Name	PWM1_PRD[7:0]							

Bit Number	Bit Mnemonic	Description
7-0	PWM1_PRD[7:0]	PWM1_PRD[7:0] sets the output period of PWM1, and is paired with PWM1_PRD[15:8] to form a 16-bit of duty cycle control value. PWM1 period: SOURCE clock/ (PWM1_PRD[15:0]+1), source clock: 12/24 MHz IRC, DC ~ 24 MHz Crystal OSC. 32 kHz IRC and 32.768 kHz Crystal OSC.

**PWM1 Duty Cycle Control High Bytes PWM1\_DUTY[15:8] (XFR: 0x57)**
**Reset Value: 00h**

Bit	Bit 7	Bit 6	Bit 5	Bit 4	Bit 3	Bit 2	Bit 1	Bit 0
Status	R/W	R/W	R/W	R/W	R/W	R/W	R/W	R/W
Name	PWM1_DUTY[15:8]							

Bit Number	Bit Mnemonic	Description
7-0	PWM1_DUTY[15:8]	Sets the duty cycle output of PWM1 PWM1_DUTY[15:8] sets the duty cycle of PWM1, and is paired with PWM1_DUTY[7:0] to form a 16-bit of duty cycle control value.

**Note: The maximum setting of Duty must be a reasonable value.**

**PWM1 Duty Cycle Control Low Bytes Register PWM1\_DUTY[7:0] (XFR: 0x58)**
**Reset Value: 00h**

Bit	Bit 7	Bit 6	Bit 5	Bit 4	Bit 3	Bit 2	Bit 1	Bit 0
Status	R/W	R/W	R/W	R/W	R/W	R/W	R/W	R/W
Name	PWM1_DUTY[7:0]							

Bit Number	Bit Mnemonic	Description
7-0	PWM1_DUTY[7:0]	Sets the duty cycle of PWM1 PWM1_DUTY[7:0] sets the duty cycle of PWM1, and is paired with PWM1_DUTY[15:8] to form a 16-bit duty cycle control value.

**Note: The maximum setting of Duty must be a reasonable value.**

**PWM0/PWM1 Period Setting example:**

$$\text{Period} = \frac{\text{Source clock (if: IRC 12MHz)}}{\text{PWMx\_PRD} + 1}$$

PWMx_PRD	PWM output period
1	6 MHz (Max.)
3	3 MHz
11	1 MHz
23	500 kHz
59	200 kHz
119	100 kHz
239	50 kHz
599	20 kHz
1199	10 kHz
2399	5 kHz
2999	4 kHz
3999	3 kHz
5999	2 kHz
11999	1 kHz
23999	500 Hz
29999	400 Hz
39999	300 Hz
59999	200 Hz
65535	183.1 Hz (Min.)

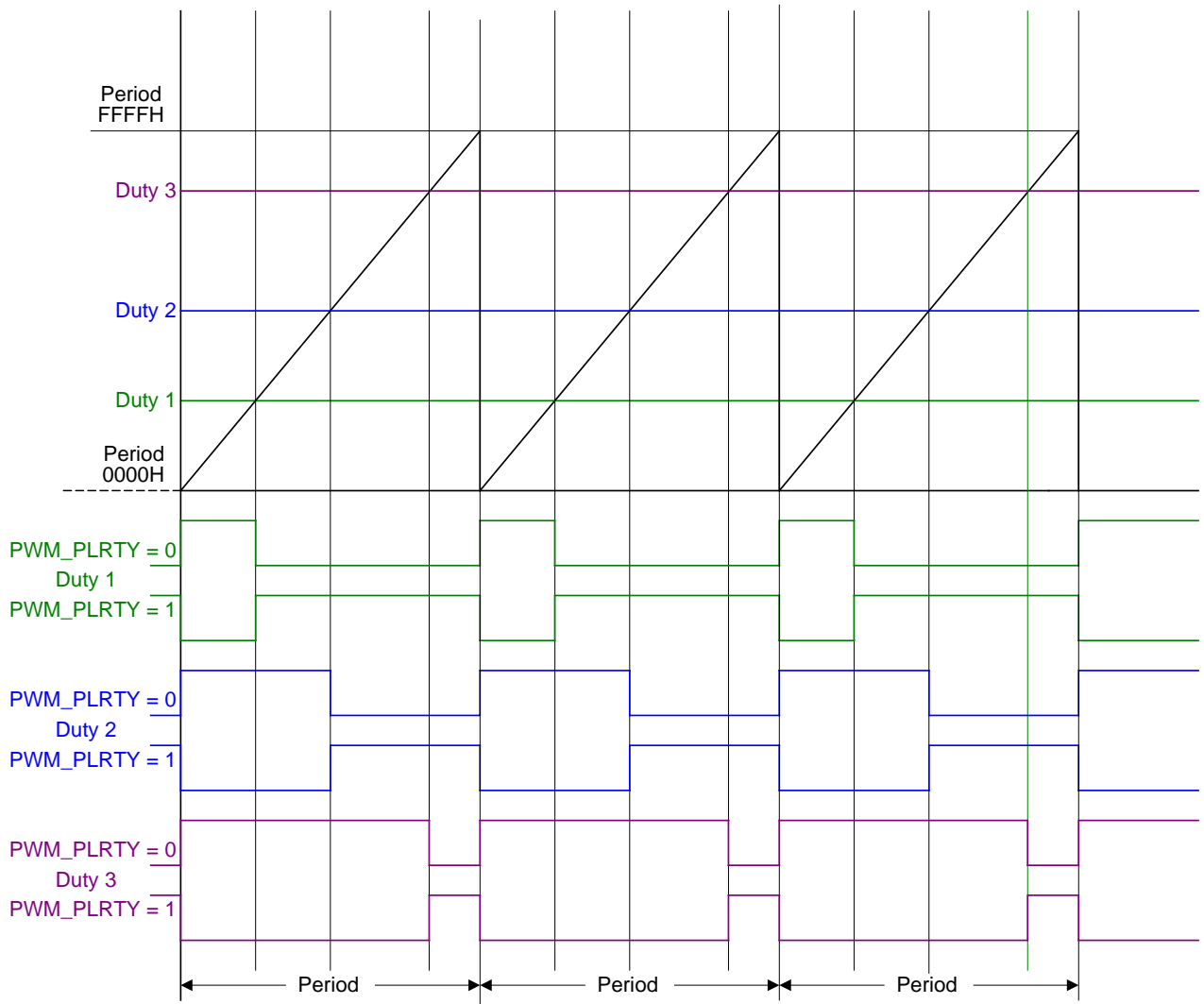

## 6.7 Power Management

WT51F108S/104S provides four operation modes, as listed below.

- Normal mode
- Green mode
- Idle mode
- Sleep mode

Four operation mode switching is illustrated in the figure below:

Operating Mode	8052	Peripheral Clock	XTAL (12 MHz)	XTAL (32.768 kHz)	IRC (12 MHz)	IRC (32 kHz)	Power Consumption@5V	Note
Normal 1	on	on	off	off	on	on	1.5 mA	*1
Normal 2	on	on	off	on	on	on	1.5 mA	*2
Normal 3	on	on	on	off	off	off	1.74 mA	*3
Green 1	on	on	off	off	off	on	14 uA	*4 *6
Green 2	on	on	off	on	off	on	16.5 uA	*5 *6
Idle 1	off	on	off	off	on	on	490 uA	*7 *9 *12
Idle 2	off	off	off	off	on	on	320 uA	*8 *9 *12
Sleep 1	off	off	off	off	off	off	75 uA	*10 *12
Sleep 2	off	off	off	off	off	off	5 uA	*11 *12

### Notes:

1. LVD & LVDR power consumption is about 10uA@5V
2. LVR power consumption is about 2uA@5V

\*1 Normal 1 Mode: MCU all use the internal oscillator, and therefore this mode is the most cost-saving mode, but IRC 12/24 MHz will be affected by the impact of temperature, please refer to section 7.5.

\*2 Normal 2 Mode: use external oscillator 32.768 kHz to calibrate IRC 12/24 MHz of WT51F108S/104S, and calibration can reach  $\pm 1\%$ .

\*3 Normal 3 Mode: this mode is focused on precise high frequency. Calendar or Clock function can only be achieved by 8052 Timer due to without external 32.768 kHz oscillator.

\*4 Green 1 Mode: Source clock select internal IRC 32 kHz, and the frequency tolerance of internal IRC 32 kHz is  $\pm 30\%$ .

\*5 Green 2 Mode: Source clock also selects internal IRC 32 kHz and it requires manually turning on the power of external crystal oscillator 32.768 kHz (CRY\_12M\_PD) manually. In addition, the system reference source of the Watch Timer selects external crystal oscillator 32.768 kHz, and have the External Clock Source Prescaler (CRY\_DIV[9:0]=1) setting divided by 2. In the meantime, the time period selected by the Watch Timer will be extended twice. Due to the external crystal oscillator 32.768 kHz with small frequency tolerance, Calendar or Clock function can be achieved by Watch Timer.

MCU Source Clock	Watch Timer Clock	Power Consumption	Note
IRC 32 kHz	IRC 32 kHz	< 20uA@5V	
IRC 32 kHz	Ext 32.768 kHz	< 20uA@5V	IRC 32 kHz $\pm 30\%$ This mode cannot capture the Interrupt Event of Watch Timer due to System clock < Watch Timer Clock.
IRC 32 kHz	Ext 32.768 kHz / 2 = 16.384 kHz		EN_CRY_DIV = 1 & CRY_DIV[9:0] = 1
Ext 32.768 kHz	Ext 32.768 kHz		

\*6 Prior to switching back to Normal Mode in Green 1 & 2 mode, please turn on IRC\_12M\_PD2 or CRY\_12M\_PD first, then select Source clock to work at internal IRC Oscillator (12 MHz) or external crystal oscillator (12 MHz).

\*7 Idle 1 Mode: Enable MCU\_CLK\_OFF to enter Idle mode, this mode wakeup fast and support the most wakeup sources, please refer to the Wakeup source illustration figure as below.

\*8 Idle 2 Mode: Enable SYSTEM\_CLK\_OFF to enter Idle mode, this mode turn off Peripheral Clock, thus MCU cannot use INT0/1/2\_WK to wakeup, please refer to the Wakeup source illustration figure as below.

\*9 Wakeup time of Idle 1 & Idle 2 Mode: 2 clocks

If Source clock = 12 MHz, wakeup time:  $2 * (1/12 \text{ MHz}) = 166\text{ns}$ ;

If Source clock = 24 MHz, wakeup time:  $2 * (1/24 \text{ MHz}) = 83.3\text{ns}$ ;

If Source clock = 32 kHz, Wakeup time:  $2 * (1/32 \text{ kHz}) = 62.5\mu\text{s}$ .

\*10 Sleep 1 Mode.: This mode is about Source clock enable IRC12M\_CLK\_OFF at IRC 12 MHz, allowing MCU to enter Sleep mode, and support fast Wakeup. The wakeup time is  $8 * (1/12 \text{ MHz}) = 666\text{ns}@12 \text{ MHz}$  (Sleep 1 mode only supports IRC12M). Please refer to the Wakeup source illustration figure as below.

\*11 Sleep 2 Mode.: Enable SOURCE\_CLK\_OFF to enter Sleep mode.

If Source clock = IRC oscillator (in the meantime, Sleep 2 only supports IRC12M), the wakeup time is 128 clocks.  $128 * (1/12 \text{ MHz}) = 10.66\mu\text{s}@12 \text{ MHz}$ ;

If Source clock = External crystal oscillator, the wakeup time is  $16 * 1024$  clocks.

$16 * 1024 * (1/12 \text{ MHz}) = 1360\mu\text{s}@12 \text{ MHz}$  or  $16 * 1024 * (1/24 \text{ MHz}) = 680\text{ns}@24 \text{ MHz}$ .

Please refer to the Wakeup source illustration figure as below.

\*12 Adopts Watch Timer Wakeup in Idle & Sleep mode, turn on the External Sub crystal oscillator power (IRC\_32K\_PD or CRY\_12M\_PD) as the clock source of Watch Timer, in the meantime the power-consuming is increasing.

MCU Operation Mode figure:

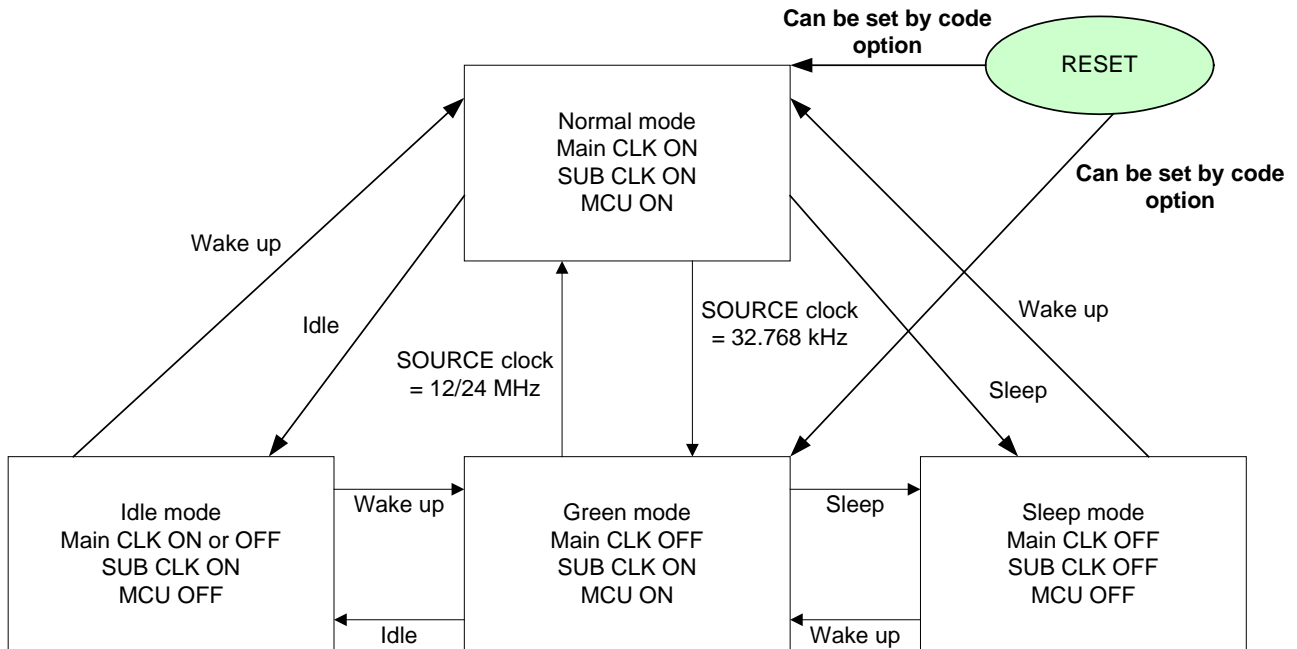



WT51F108S/104S provides many sources of wakeup returning itself from sleep/idle mode to normal mode.

The figure below illustrated the Wakeup sources below each mode:

SOURCE		Idle 1	Idle 2	Sleep Mode
		MCU_CLK_OFF	SYSTEM_CLK_OFF	SOURCE_CLK_OFF IRC12M_CLK_OFF
NRST		●	●	●
GPIOx_WK[x]		●	●	●
INTWK	IE0_S12C	●		
	IE0_ADC			
	IE0_LVD	●	●	●
	IE0_WTMR			
	IE0_ETIMER	●		
	IE0_IN_TOG	●	●	●
INT3_WK	IRQ[7:0]	●		
ADC_WK		●	●	●
WTMR_WK		●	●	●

**Notes:**

- GPIOx\_WK[x] & IE0\_IN\_TOG: only support 11 general-purpose I/O pin Toggle (GPIO A/B).
- IRQ[7:0]: IRQ did not support wakeup, please use GPIOx\_WK[x] to wakeup.
- ADC\_WK: Based on input source for comparing Toggle wakeup
- WTMR\_WK: Turn on sub crystal oscillator (IRC 32 kHz or Ext 32 kHz) and sub crystal oscillator power to be the clock source of Watch Timer.

**ISP Clock Source Control Register ISP\_CHG\_CTL (XFR: 0x04)**
**Reset Value: 00h**

Bit	Bit 7	Bit 6	Bit 5	Bit 4	Bit 3	Bit 2	Bit 1	Bit 0
Status	R/W	-	R/W	R	-	-	R	R
Name	ISP_CHG_12M	Reserved	UART_ISP_CHG	ISP_CHG_FLAG	Reserved	Reserved	LVD_RST_ACT_FLG	LVR_ACT_FLG

Bit Number	Bit Mnemonic	Description
7	ISP_CHG_12M	When MCU is in Green & Sleep mode, ISP pin will turn on the internal 12/24 MHz RC oscillator automatically 1: Enable 0: Disable
6	Reserved	-
5	UART_ISP_CHG	UART pin (GPIA3) trigger ISP clock source as internal 12/24 MHz RC oscillator 1: Enable 0: Disable
4	ISP_CHG_FLAG	ISP_CHG_FLAG = 1: MCU is wakened up by SWUT pin. Turn on internal 12/24 MHz RC oscillator and switch SOURCE clock to Internal RC oscillator. Clear ISP_CHG_FLAG by setting ISP_CHG_12M bit = 0.
3-2	Reserved	-
1	LVD_RST_ACT_FLG	1: Power Voltage < Setting Low Voltage Detection Reset Range. (This flag is not connected to the Analog Filter, and will be affected easily. For reference only.)
0	LVR_ACT_FLG	1: Power Voltage < Internal Low Voltage Reset Voltage. (This flag is not connected to the Analog Filter, and will be affected easily. For reference only.)

-: unimplemented.

**Note: If Source clock of WT51F108S/104S is in non 12 MHz application, please add below Forcing Toggle SWUT setting procedures to the program for enabling MCU programming repeatedly.**

**Non-12 MHz mode contains: Green, Sleep mode, and Internal/External oscillator (non 12 MHz) can enable ISP\_CHG\_12M & UART\_ISP\_CHG bit allow MCU pin trigger to switch the SOURCE clock & ISP clock to internal 12 MHz RC oscillator by SWUT, and meanwhile MCU can receive the correct ISP command.**

Mandatory trigger SWUT setting procedures:

1. Program Initialized Enable ISP\_CHG\_12M & UART\_ISP\_CHG bit  
rISP\_CHG\_CTL = 0xA0;
  2. Program main loop judge if ISP\_CHG\_FLAG been triggered, and based on Sleep mode to add one software mechanism, please refer to the example program.  
Void DRV\_CheckSwutTriggerWakeup(void)
- ```

{
    //If enable rISP_CHG_CTL of bit 7 and Bit.
    //When Swut pin have hi to low(2V) level, Mcu will change source clock to IRC 12 MHz
    if(rISP_CHG_CTL & 0x10)
    {

```

```

DRV_SoftwareWakeup();
//need delay 100ms(minimum) to wait ISP command, Don't remove this delay command
DelayWhile(100);           //This time MCU change source clock to IRC 12 MHz

rISP_CHG_CTL = 0x00;      //Disable ISP change clock. MCU go back to original setting
rISP_CHG_CTL = 0xA0;      //Enable ISP change clock
    }
}

```

**System Clock Source Control Register SOURCE\_CLK\_SLT (XFR: 0x05)**
**Reset Value: A0h**

| Bit    | Bit 7    | Bit 6 | Bit 5 | Bit 4 | Bit 3               | Bit 2 | Bit 1            | Bit 0 |
|--------|----------|-------|-------|-------|---------------------|-------|------------------|-------|
| Status | -        | -     | -     | -     | R/W                 | R/W   | R/W              | R/W   |
| Name   | Reserved |       |       |       | SOURCE_CLK_SLT[1:0] |       | MCU_CLK_SLT[1:0] |       |

| Bit Number | Bit Mnemonic        | Description                                                                                                                                                                                                                                                                                                                                           |
|------------|---------------------|-------------------------------------------------------------------------------------------------------------------------------------------------------------------------------------------------------------------------------------------------------------------------------------------------------------------------------------------------------|
| 7-4        | Reserved            | Must be equal to "1010", otherwise bit [3:0] cannot be written into.                                                                                                                                                                                                                                                                                  |
| 3-2        | SOURCE_CLK_SLT[1:0] | Select SOURCE clock sources<br>00: Internal 12/24 MHz RC oscillator (default)<br>01: External DC ~ 24 MHz crystal oscillator<br>10: Internal 32 kHz RC oscillator<br>Default value can be selected by section 6.17 Code Option Select<br><b>Note: Prior to switching SOURCE_CLK_SLT[1:0], please set the corresponding power of IRC_12M_PD as ON.</b> |
| 1-0        | MCU_CLK_SLT[1:0]    | MCU clock setting<br>00: MCU clock = SOURCE clock (default)<br>01: MCU clock = SOURCE clock /2<br>10: MCU clock = SOURCE clock /4<br>11: MCU clock = SOURCE clock /12                                                                                                                                                                                 |

**-: unimplemented.**

**Notes:**

- When SOURCE clock selects internal 32 kHz RC oscillator and the system clock source of the Watch Timer selects External 32.768 kHz crystal oscillator, Interrupt sources cannot be captured in time due to Internal 32 kHz RC oscillator with huge tolerance and the execute speed is slower than the Interrupt generated by Watch Timer. In this mode, it requires having the External Clock Source Prescaler Control Register 1 and External Clock Source Prescaler Control Register 2 setting divided by 2, and the Watch Timer clock source divided by 2 equals to 16.384 kHz. In the meantime, the time period selected by the Watch Timer will be extended twice to capture completely without missing.

**Setting External Clock Source/ 2 procedures:**

- Setting Prescaler Data: CRY\_DIV[9:0] = 1, and  $32.768 \text{ kHz} / (\text{CRY\_DIV}[9:0] + 1) = 32.768 \text{ kHz} / 2 = 16.384 \text{ kHz}$
- Enable external crystal oscillator clock source prescaler: EN\_CRY\_DIV = 1

**Power Saving Control Register POWER\_SAVE\_CTL (XFR: 0x06)**
**Reset Value: 50h**

| Bit    | Bit 7    | Bit 6 | Bit 5 | Bit 4       | Bit 3          | Bit 2          | Bit 1          | Bit 0 |
|--------|----------|-------|-------|-------------|----------------|----------------|----------------|-------|
| Status | -        | -     | -     | -           | R/W            | R/W            | R/W            | R/W   |
| Name   | Reserved |       |       | MCU_CLK_OFF | SYSTEM_CLK_OFF | SOURCE_CLK_OFF | IRC12M_CLK_OFF |       |

| Bit Number | Bit Mnemonic                 | Description                                                                                                                                                                                                                                                                                                                                                                                                                                                                                                                          |
|------------|------------------------------|--------------------------------------------------------------------------------------------------------------------------------------------------------------------------------------------------------------------------------------------------------------------------------------------------------------------------------------------------------------------------------------------------------------------------------------------------------------------------------------------------------------------------------------|
| 7-4        | -                            | Must be equal to "0101", otherwise, Bit[3:0] cannot be written into                                                                                                                                                                                                                                                                                                                                                                                                                                                                  |
| 3          | MCU_CLK_OFF                  | 1: MCU clock is Off (including MCU and partial peripheral hardware), and MCU must wait for <b>3~4</b> MCU clock cycles until MCU clock ON and work.<br>0: MCU clock is On.                                                                                                                                                                                                                                                                                                                                                           |
| 2          | SYSTEM_CLK_OFF               | 1: System clock is Off (including MCU and partial peripheral hardware), and MCU must wait for <b>3~4</b> MCU clock cycles until system clock ON and work.<br>0: MCU clock is On.                                                                                                                                                                                                                                                                                                                                                     |
| 1          | SOURCE_CLK_OFF<br>(bias OFF) | 1: SOURCE clock is Off.<br>SOURCE clock sources: (MCU clock is turned off and bias OFF)<br><b>(1) External crystal oscillator (24 MHz ~ 32.768 kHz), and MCU must wait for 16385~16386 SYSTEM clock cycles until source clock ON and work.</b><br><b>(2) Internal RC oscillator (12 MHz), and MCU must wait for 129~130 SYSTEM clock cycles until source clock ON and work.</b><br><b>(3) Internal RC oscillator (32 kHz), and MCU must wait for 9~10 SYSTEM clock cycles until source clock ON and work.</b><br>0: MCU clock is On. |
| 0          | IRC12M_CLK_OFF<br>(bias ON)  | 1: Internal 12/24 MHz RC oscillator is Off and bias ON<br>MCU must wait for <b>11~12 IRC 12 MHz clock + IRC Start-up (about 10 μs)</b> until source clock ON and work.<br>0: MCU clock is On.                                                                                                                                                                                                                                                                                                                                        |

-: unimplemented.

Note: Refer to section 3.1 System Clock Tree for more details.

**Clock Source Control Register IRC\_12M\_PD (XFR: 0x07)**
**Reset Value: A2h**

| Bit    | Bit 7    | Bit 6 | Bit 5 | Bit 4       | Bit 3       | Bit 2      | Bit 1      | Bit 0    |
|--------|----------|-------|-------|-------------|-------------|------------|------------|----------|
| Status | -        | -     | -     | R/W         | R/W         | R/W        | R/W        | -        |
| Name   | Reserved |       |       | IRC_12M_PD1 | IRC_12M_PD2 | IRC_32K_PD | CRY_12M_PD | Reserved |

| Bit Number | Bit Mnemonic | Description                                                                                                        |
|------------|--------------|--------------------------------------------------------------------------------------------------------------------|
| 7-5        | -            | Must be equal to "101", otherwise bit[4:0] cannot be written into                                                  |
| 4          | IRC_12M_PD1  | 1: Partial internal 12/24 MHz RC oscillator power is turned off (bias ON) (default value is not off)<br>0: Not off |

| Bit Number | Bit Mnemonic | Description                                                                                                      |
|------------|--------------|------------------------------------------------------------------------------------------------------------------|
| 3          | IRC_12M_PD2  | 1: All internal 12/24 MHz RC oscillator power are turned off (bias off) (default value is not off)<br>0: Not off |
| 2          | IRC_32K_PD   | 1: Internal 32 kHz RC oscillator power is turned off (default value is not off)<br>0: Not off                    |
| 1          | CRY_12M_PD   | 1: External 12/24 MHz ~ 32 kHz crystal oscillator power is turned off (default value is off)<br>0: Not off       |
| 0          | Reserved     | -                                                                                                                |

-: unimplemented.

**Note:** In Green mode, IRC\_12M\_PD (XFR\_0x07) must be set by the customer to turn off unnecessary clock source for power saving.

**Oscillator Driver Control Register CRY\_12M\_DR[1:0] (XFR: 0x08)**
**Reset Value: 54h**

| Bit    | Bit 7    | Bit 6 | Bit 5 | Bit 4 | Bit 3      | Bit 2           | Bit 1    | Bit 0 |
|--------|----------|-------|-------|-------|------------|-----------------|----------|-------|
| Status | -        | -     | -     | -     | -          | R/W             | R/W      | -     |
| Name   | Reserved |       |       |       | CRY_DR_ENH | CRY_12M_DR[1:0] | Reserved |       |

| Bit Number | Bit Mnemonic    | Description                                                                                                                                                                                                                                                                                                                                                                                                                                                                                                                                                                                                                                                                                                                                                                                                                                                                                                                   |
|------------|-----------------|-------------------------------------------------------------------------------------------------------------------------------------------------------------------------------------------------------------------------------------------------------------------------------------------------------------------------------------------------------------------------------------------------------------------------------------------------------------------------------------------------------------------------------------------------------------------------------------------------------------------------------------------------------------------------------------------------------------------------------------------------------------------------------------------------------------------------------------------------------------------------------------------------------------------------------|
| 7-4        | Reserved        | Must be equal to "0101", otherwise, Bit[3:0] cannot be written into                                                                                                                                                                                                                                                                                                                                                                                                                                                                                                                                                                                                                                                                                                                                                                                                                                                           |
| 3          | CRY_DR_ENH      | 1: Enhanced the driving ability of External Crystal Oscillator                                                                                                                                                                                                                                                                                                                                                                                                                                                                                                                                                                                                                                                                                                                                                                                                                                                                |
| 2-1        | CRY_12M_DR[1:0] | If CRY_DR_ENH =0; External oscillator driving ability setting<br>00: Crystal oscillator with frequency of 32 kHz, power consumption < 3uA<br>01: Crystal oscillator with frequency of 100 kHz ~ 1 MHz, power consumption < 60uA<br>10: Crystal oscillator with frequency of 1 MHz ~ 12 MHz, power consumption < 300uA (default)<br>11: Crystal oscillator with frequency of 12 MHz ~ 24 MHz, power consumption < 600uA<br><br>If CRY_DR_ENH =1; External oscillator driving ability setting<br>00: Crystal oscillator with frequency of 32 kHz, power consumption < 10uA<br>01: Crystal oscillator with frequency of 100 kHz ~ 1 MHz, power consumption < 80uA<br>10: Crystal oscillator with frequency of 1 MHz ~ 12 MHz, power consumption < 400uA (default)<br>11: Crystal oscillator with frequency of 12 MHz ~ 24 MHz, power consumption < 800uA<br><br>Default value can be selected by section 6.17 Code Option Select |
| 0          | Reserved        | -                                                                                                                                                                                                                                                                                                                                                                                                                                                                                                                                                                                                                                                                                                                                                                                                                                                                                                                             |

-: unimplemented.

**Note:** Due to WT51F108S/104S only supports one set of external oscillator input, it requires setting the driving ability of oscillator according to the frequency of external oscillator input.  
Please see the table below.

| External Crystal Oscillator | CRY_12M_DR[1:0] |
|-----------------------------|-----------------|
| 24 MHz ~ 12MHz              | 11              |
| 12 MHz ~ 1MHz               | 10              |
| 1MHz ~ 100kHz               | 01              |
| 32.768 kHz                  | 00              |

**General-purpose I/O Port A Wakeup Control Register GPIOA\_WK[5:0] (XFR: 0x60)      Reset Value: 00h**

| Bit    | Bit 7    | Bit 6 | Bit 5         | Bit 4 | Bit 3 | Bit 2 | Bit 1 | Bit 0 |
|--------|----------|-------|---------------|-------|-------|-------|-------|-------|
| Status | -        | -     | R/W           | R/W   | R/W   | R/W   | R/W   | R/W   |
| Name   | Reserved |       | GPIOA_WK[5:0] |       |       |       |       |       |

| Bit Number | Bit Mnemonic  | Description                                                                                                                                                                                                                                                                                                                                                                                                                                                                                                                                                                                                                              |
|------------|---------------|------------------------------------------------------------------------------------------------------------------------------------------------------------------------------------------------------------------------------------------------------------------------------------------------------------------------------------------------------------------------------------------------------------------------------------------------------------------------------------------------------------------------------------------------------------------------------------------------------------------------------------------|
| 7-6        | Reserved      | -                                                                                                                                                                                                                                                                                                                                                                                                                                                                                                                                                                                                                                        |
| 5-0        | GPIOA_WK[5:0] | General-purpose I/O Port A Wakeup MCU Enable setting<br>Bit 5 = 1: Enable General-purpose I/O Port A5 Wakeup MCU function;<br>0: Function disabled<br>Bit 4 = 1: Enable General-purpose I/O Port A4 Wakeup MCU function;<br>0: Function disabled<br>Bit 3 = 1: Enable General-purpose I/O Port A3 Wakeup MCU function;<br>0: Function disabled<br>Bit 2 = 1: Enable General-purpose I/O Port A2 Wakeup MCU function;<br>0: Function disabled<br>Bit 1 = 1: Enable General-purpose I/O Port A1 Wakeup MCU function;<br>0: Function disabled<br>Bit 0 = 1: Enable General-purpose I/O Port A0 Wakeup MCU function;<br>0: Function disabled |

**-: unimplemented.**

**General-purpose I/O Port B Wakeup Control Register GPIOB\_WK[5:0] (XFR: 0x61)      Reset Value: 00h**

| Bit    | Bit 7    | Bit 6 | Bit 5         | Bit 4 | Bit 3 | Bit 2 | Bit 1 | Bit 0 |
|--------|----------|-------|---------------|-------|-------|-------|-------|-------|
| Status | -        | -     | R/W           | R/W   | R/W   | R/W   | R/W   | R/W   |
| Name   | Reserved |       | GPIOB_WK[5:0] |       |       |       |       |       |

| Bit Number | Bit Mnemonic  | Description                                                                                                                                                                                                                                      |
|------------|---------------|--------------------------------------------------------------------------------------------------------------------------------------------------------------------------------------------------------------------------------------------------|
| 7-6        | Reserved      | -                                                                                                                                                                                                                                                |
| 5-0        | GPIOB_WK[5:0] | General-purpose I/O Port B Trigger Wakeup MCU Enable setting<br>Bit 5 = 1: Enable General-purpose I/O Port B5 Trigger Wakeup MCU function;<br>0: Function disabled<br>Bit 4 = 1: Enable General-purpose I/O Port B4 Trigger Wakeup MCU function; |

| Bit Number | Bit Mnemonic | Description                                                                                                                                                                                                                                                                                                                                                           |
|------------|--------------|-----------------------------------------------------------------------------------------------------------------------------------------------------------------------------------------------------------------------------------------------------------------------------------------------------------------------------------------------------------------------|
|            |              | 0: Function disabled<br>Bit 3 = 1: Enable General-purpose I/O Port B3 Trigger Wakeup MCU function;<br>0: Function disabled<br>Bit 2 = 1: Enable General-purpose I/O Port B2 Trigger Wakeup MCU function;<br>0: Function disabled<br>Bit 1 = 1: Enable General-purpose I/O Port B1 Trigger Wakeup MCU function;<br>0: Function disabled<br>Bit 0 = 1: must be set as 0 |

-: unimplemented.

**Peripheral Interrupt Wakeup Control Register PERIPHERAL\_WK (XFR: 0x64)                      Reset Value: 00h**

| Bit    | Bit 7   | Bit 6    | Bit 5 | Bit 4   | Bit 3  | Bit 2    | Bit 1   | Bit 0    |
|--------|---------|----------|-------|---------|--------|----------|---------|----------|
| Status | R/W     | -        | -     | R/W     | R/W    | -        | R/W     | -        |
| Name   | INT3_WK | Reserved |       | INT0_WK | ADC_WK | Reserved | WTMR_WK | Reserved |

| Bit Number | Bit Mnemonic | Description                                                                                                                                                                                    |
|------------|--------------|------------------------------------------------------------------------------------------------------------------------------------------------------------------------------------------------|
| 7          | INT3_WK      | External 8052 INT3 Wakeup MCU Enable setting<br>1: Enable 8052 INT3 Wakeup MCU function<br>0: Disable 8052 INT3 Wakeup MCU function                                                            |
| 6-5        | Reserved     | Must be set as 0                                                                                                                                                                               |
| 4          | INT0_WK      | External 8052 INT0 Wakeup MCU Enable setting<br>1: Enable 8052 INT0 Wakeup MCU function<br>0: Disable 8052 INT0 Wakeup MCU function                                                            |
| 3          | ADC_WK       | ADC Compare mode Wakeup MCU Enable setting<br>1: Enable Wakeup MCU function after ADC comparing is complete<br>0: Disable Wakeup MCU function after ADC comparing is complete                  |
| 2          | Reserved     | Must be set as 0                                                                                                                                                                               |
| 1          | WTMR_WK      | Watch Timer Wakeup MCU Enable setting<br>1: Enable Watch Timer Wakeup MCU function after Watch Timer is triggered<br>0: Disable Watch Timer Wakeup MCU function after Watch Timer is triggered |
| 0          | Reserved     | Must be set as 0                                                                                                                                                                               |

-: unimplemented.

**General-purpose I/O Port A Wakeup Flag Register GPIOA\_TOG[5:0] (XFR: 0x65)                      Reset Value: 00h**

| Bit    | Bit 7    | Bit 6 | Bit 5          | Bit 4 | Bit 3 | Bit 2 | Bit 1 | Bit 0 |
|--------|----------|-------|----------------|-------|-------|-------|-------|-------|
| Status | -        | -     | R              | R     | R     | R     | R     | R     |
| Name   | Reserved |       | GPIOA_TOG[5:0] |       |       |       |       |       |

| Bit Number | Bit Mnemonic   | Description                                                                                                                                                                                                                                                                                                                       |
|------------|----------------|-----------------------------------------------------------------------------------------------------------------------------------------------------------------------------------------------------------------------------------------------------------------------------------------------------------------------------------|
| 7-6        | Reserved       | -                                                                                                                                                                                                                                                                                                                                 |
| 5-0        | GPIOA_TOG[5:0] | General-purpose I/O Port A Trigger Wakeup Flag. If the corresponding bit Toggle Trigger occurred, Wakeup Flag Bit = 1<br>Bit 5: I/O Port A5 Wakeup Flag<br>Bit 4: I/O Port A4 Wakeup Flag<br>Bit 3: I/O Port A3 Wakeup Flag<br>Bit 2: I/O Port A2 Wakeup Flag<br>Bit 1: I/O Port A1 Wakeup Flag<br>Bit 0: I/O Port A0 Wakeup Flag |

:- unimplemented.

**General-purpose I/O Port B Wakeup Flag Register GPIOB\_TOG[5:0] (XFR: 0x66)      Reset Value: 00h**

| Bit    | Bit 7    | Bit 6 | Bit 5          | Bit 4 | Bit 3 | Bit 2 | Bit 1 | Bit 0 |
|--------|----------|-------|----------------|-------|-------|-------|-------|-------|
| Status | -        | -     | R              | R     | R     | R     | R     | R     |
| Name   | Reserved |       | GPIOB_TOG[5:0] |       |       |       |       |       |

| Bit Number | Bit Mnemonic   | Description                                                                                                                                                                                                                                                                                                                |
|------------|----------------|----------------------------------------------------------------------------------------------------------------------------------------------------------------------------------------------------------------------------------------------------------------------------------------------------------------------------|
| 7-6        | Reserved       | -                                                                                                                                                                                                                                                                                                                          |
| 5-0        | GPIOB_TOG[5:0] | General-purpose I/O Port B Trigger Wakeup Flag. If the corresponding bit Toggle Trigger occurred, Wakeup Flag Bit = 1<br>Bit 5: I/O Port B5 Wakeup Flag<br>Bit 4: I/O Port B4 Wakeup Flag<br>Bit 3: I/O Port B3 Wakeup Flag<br>Bit 2: I/O Port B2 Wakeup Flag<br>Bit 1: I/O Port B1 Wakeup Flag<br>Bit 0: Must be set as 0 |

:- unimplemented.

**Peripheral Interrupt Wakeup Flag Register PERIPHERAL\_TOG (XFR: 0x69)      Reset Value: 00h**

| Bit    | Bit 7       | Bit 6    | Bit 5 | Bit 4       | Bit 3   | Bit 2    | Bit 1    | Bit 0    |
|--------|-------------|----------|-------|-------------|---------|----------|----------|----------|
| Status | R           | -        | -     | R           | R       | -        | R        | -        |
| Name   | INT3_WK_EVT | Reserved |       | INT0_WK_EVT | ADC_TOG | Reserved | WTMR_EVT | Reserved |

| Bit Number | Bit Mnemonic | Description                                                                                                                        |
|------------|--------------|------------------------------------------------------------------------------------------------------------------------------------|
| 7-4        | INT3_WK_EVT  | Interrupt Wakeup Flag<br>1: Enable INT3 Interrupt Wakeup MCU function                                                              |
| 6-5        | Reserved     | -                                                                                                                                  |
| 4          | INT0_WK_EVT  | Interrupt Wakeup Flag<br>1: Enable INT0 Interrupt Wakeup MCU function                                                              |
| 3          | ADC_TOG      | ADC Compare mode Trigger (Wakeup) Flag<br>1: ADC compare mode trigger has occurred<br>0: ADC compare mode trigger has not occurred |
| 2          | Reserved     | Must be set as 0                                                                                                                   |



| Bit Number | Bit Mnemonic | Description                                                                                                            |
|------------|--------------|------------------------------------------------------------------------------------------------------------------------|
| 1          | WTMR_EVT     | Watch Timer Trigger (Wakeup) Flag<br>1: Enable Watch Timer Trigger (Wakeup)<br>0: Disable Watch Timer Trigger (Wakeup) |
| 0          | Reserved     | Must be set as 0                                                                                                       |

-: unimplemented.

**Wakeup Clear Register CLR\_IN\_TOG (XFR: 0x6A)**
**Reset Value: 00h**

| Bit    | Bit 7      | Bit 6    | Bit 5 | Bit 4 | Bit 3 | Bit 2 | Bit 1 | Bit 0  |
|--------|------------|----------|-------|-------|-------|-------|-------|--------|
| Status | W          | -        | -     | -     | -     | -     | -     | R      |
| Name   | CLR_IN_TOG | Reserved |       |       |       |       |       | IN_TOG |

| Bit Number | Bit Mnemonic | Description                                                                                   |
|------------|--------------|-----------------------------------------------------------------------------------------------|
| 7          | CLR_IN_TOG   | 1: Clear all Input Toggle                                                                     |
| 6-1        | Reserved     | -                                                                                             |
| 0          | IN_TOG       | 1: All toggle events logic- or operation if any toggle source occurred, this bit will be set. |

-: unimplemented.

**The setting of entering Sleep Mode and Wakeup procedure:**

1. Set RST\_NDF = 1
2. Enable Watchdog Timer (DIS\_WDT[7:5] = 101)
3. Select Wakeup sources:

| Wakeup Sources |                                                        | Sleep Mode | Idle Mode   |              |
|----------------|--------------------------------------------------------|------------|-------------|--------------|
|                |                                                        | No Clock   | Sub: 32 kHz | Main: 12 MHz |
| 1.             | NRST pin is low voltage                                | ●          | ●           | ●            |
| 2.             | External Interrupt INT0 sources                        |            |             |              |
|                | > Low Voltage Detection interrupt                      | ●          | ●           | ●            |
|                | > Watch Timer interrupt                                |            | ●           | ●            |
|                | > Enhanced Timer/Counter interrupt                     |            |             | ●            |
|                | > 11 General-purpose I/O pin Toggle interrupt          |            |             | ●            |
| 3.             | External interrupt INT3 sources (GPIO A/B/C)           |            |             |              |
|                | > 8 IRQ interrupt pins                                 |            |             | ●            |
| 4.             | 11 General-purpose I/O pin Toggle interrupt (GPIO A/B) | ●          | ●           | ●            |
| 5.             | ADC_WK (Compare Mode)                                  | ●          | ●           | ●            |
| 6.             | WTMR_WK                                                | ●          | ●           | ●            |

4. Select internal 12 MHz RC oscillator as SOURCE clock (SOURCE\_CLK\_SLT[1:0] = 00)
    - (4-A) Clear HFIRC\_CLK\_SLT (XFR\_0x01 bit2)**
    - (4-B) Move Flash memory XDATA 0x0E03 to register XFR-0x70**
  5. Clear all input Trigger Wakeup (CLR\_IN\_TOG = 1)
  6. Enter Sleep Mode (SOURCE\_CLK\_OFF = 1)
  7. Wait for Wakeup Trigger
    - SOURCE clock = IRC 12 MHz, needs to wait for 128 clock cycles to return to the main program
    - SOURCE clock = Crystal, needs to wait for 16 x 1024 clock cycles to return to the main program
    - (7-A) Set HFIRC\_CLK\_SLT (XFR\_0x01 bit2)**
    - (7-B) Move Flash memory XDATA 0x0E07 to register XFR-0x70**
- \* (4-A), (4-B), (7-A), and (7-B) need to be executed only in IRC24M.
- \* If Source Clock = IRC oscillator, please switch to IRC 12 MHz to ensure wakeup function before entering Sleep1/Sleep2 mode.

## 6.8 12 MHz/24 MHz RC Oscillator Calibration

WT51F108S/104S has a built-in 12/24 MHz RC oscillator to reduce the cost of external crystal oscillator. For more precise system clock, external crystal oscillator 12/24 MHz is available. In addition, it is a better choice to use 32.768 kHz (crystal oscillator) to calibrate internal RC 12/24 MHz oscillators. (Calibration can reach  $\pm 1\%$  at  $-40^{\circ}\text{C} \sim +85^{\circ}\text{C}$ )

### Internal Oscillator Adjust Register RC\_LADJ (XFR: 0x70)

**Reset Value: 40h**

|        |          |                |       |       |                |       |       |       |
|--------|----------|----------------|-------|-------|----------------|-------|-------|-------|
| Bit    | Bit 7    | Bit 6          | Bit 5 | Bit 4 | Bit 3          | Bit 2 | Bit 1 | Bit 0 |
| Status | -        | R/W            | R/W   | R/W   | R/W            | R/W   | R/W   | R/W   |
| Name   | Reserved | RC_LADJ_C[2:0] |       |       | RC_LADJ_F[3:0] |       |       |       |

| Bit Number | Bit Mnemonic   | Description                                                                                                        |
|------------|----------------|--------------------------------------------------------------------------------------------------------------------|
| 7          | Reserved       | -                                                                                                                  |
| 6-4        | RC_LADJ_C[2:0] | Each level 8% coarse adjustment of the Internal RC oscillator frequency (default value '100'), 7 levels in total   |
| 3-0        | RC_LADJ_F[3:0] | Each level 0.5% fine adjustment of the Internal RC oscillator frequency (default value '1000'), 15 levels in total |

:- unimplemented.

**Note: Internal Oscillator Adjustment Register RC\_LADJ\_C[2:0] & RC\_LADJ\_F[3:0] is allowed to adjust the control circuit of IRC 12/24 MHz directly.**

### Internal Oscillator Counter Data High Bytes Register RC12M\_CNT[9:2] (XFR: 0x71)

**Reset Value: 00h**

|        |                |       |       |       |       |       |       |       |
|--------|----------------|-------|-------|-------|-------|-------|-------|-------|
| Bit    | Bit 7          | Bit 6 | Bit 5 | Bit 4 | Bit 3 | Bit 2 | Bit 1 | Bit 0 |
| Status | R              | R     | R     | R     | R     | R     | R     | R     |
| Name   | RC12M_CNT[9:2] |       |       |       |       |       |       |       |

| Bit Number | Bit Mnemonic   | Description                                                                                                                          |
|------------|----------------|--------------------------------------------------------------------------------------------------------------------------------------|
| 7-0        | RC12M_CNT[9:2] | The counting value RC12M_CNT[9:2] of internal 12/24 MHz RC oscillator, is paired with RC12M_CNT[1:0] to form a 10-bit counting value |

### Internal Oscillator Counter Data Low Bytes Register RC12M\_CNT[1:0] (XFR: 0x72)

**Reset Value: 00h**

|        |          |       |       |       |       |       |                |       |
|--------|----------|-------|-------|-------|-------|-------|----------------|-------|
| Bit    | Bit 7    | Bit 6 | Bit 5 | Bit 4 | Bit 3 | Bit 2 | Bit 1          | Bit 0 |
| Status | -        | -     | -     | -     | -     | -     | R              | R     |
| Name   | Reserved |       |       |       |       |       | RC12M_CNT[1:0] |       |

:- unimplemented.

| Bit Number | Bit Mnemonic   | Description                                                                                                                          |
|------------|----------------|--------------------------------------------------------------------------------------------------------------------------------------|
| 7-2        | Reserved       | -                                                                                                                                    |
| 1-0        | RC12M_CNT[1:0] | The counting value RC12M_CNT[1:0] of internal 12/24 MHz RC oscillator, is paired with RC12M_CNT[9:2] to form a 10-bit counting value |

-: unimplemented.

**Internal Oscillator Calibration Control Register RC\_CALIB\_EN (XFR: 0x73)**
**Reset Value: 00h**

| Bit    | Bit 7       | Bit 6    | Bit 5       | Bit 4    | Bit 3 | Bit 2 | Bit 1 | Bit 0 |
|--------|-------------|----------|-------------|----------|-------|-------|-------|-------|
| Status | R/W         | -        | R/W         | -        | -     | -     | -     | -     |
| Name   | RC_CALIB_EN | Reserved | AUTO_CAL_EN | Reserved |       |       |       |       |

| Bit Number | Bit Mnemonic | Description                                  |
|------------|--------------|----------------------------------------------|
| 7          | RC_CALIB_EN  | 1: Enable RC Oscillator Calibration function |
| 6          | Reserved     | -                                            |
| 5          | AUTO_CAL_EN  | 1: Enable H/W automatic calibration function |
| 4-0        | Reserved     | -                                            |

-: unimplemented.

**Note:**

**Manual calibration:** enable RC\_CALIB\_EN, and is working together with Firmware.

**Automatic calibration:** enable RC\_CALIB\_EN and AUTO\_CAL\_EN.

**Internal Oscillator Calibration Compare Data Register RC\_ACTCV\_CNT (XFR: 0x74)**
**Reset Value: 0x5B**

| Bit    | Bit 7          | Bit 6 | Bit 5 | Bit 4 | Bit 3 | Bit 2 | Bit 1 | Bit 0 |
|--------|----------------|-------|-------|-------|-------|-------|-------|-------|
| Status | RW             | RW    | RW    | RW    | RW    | RW    | RW    | RW    |
| Name   | ACTCV_CNT[7:0] |       |       |       |       |       |       |       |

| Bit Number | Bit Mnemonic   | Description                                                                                                                                       |
|------------|----------------|---------------------------------------------------------------------------------------------------------------------------------------------------|
| 7-0        | ACTCV_CNT[7:0] | Auto Calibration target counter value (If AUTO_CAL_EN =1, MCU will auto compare with RC12M_CNT[9:2] then adjust RC_LADJ_F[3:0] & RC_LADJ_C[2:0]). |

**Note:** When using Auto Calibration Internal IRC 24MHz, RC\_ACTCV\_CNT register must be set manually to 0xB7.

**Calculation method:**  $RC12M\_CNT[9:0] = 24000/32.768 = 732$ , due to comparing with RC12M\_CNT[9:2] and omitting comparing bit 1 & 0, 732 shall be divided by 4 equals 183.

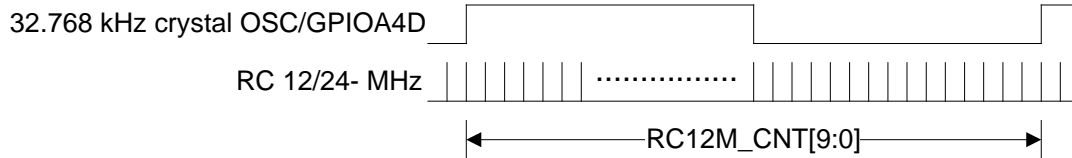

### Calibration Theory:

When the external 32.768 kHz oscillator is used, it is available to count in the fixed width of precise 32.768 kHz by internal RC 12/24 MHz. Then with the counting value we got, we can make a compensation by the Control Internal Oscillator Adjust Registers RC\_LADJ\_C[2:0] & RC\_LADJ\_F[3:0], reaching  $\pm 1\%$  at room temperature.

### The range of coarse adjustment and fine adjustment:

Coarse adjustment: the actual internal RC frequency  $\pm$  (internal RC frequency \* 0.08); RC\_LADJ\_C[2:0] ranges from 000 ~ 111, and the middle value is 100.

Fine adjustment: the actual internal RC frequency  $\pm$  (internal RC frequency \* 0.005); RC\_LADJ\_F[3:0] ranges from 0000 ~ 1111, and the middle value is 1000.

### RC 12 MHz

| RC12M_CNT[9:0] | External 32.768 kHz Sampled (Hz) | Target Value (Hz) | Tolerance % |
|----------------|----------------------------------|-------------------|-------------|
| 360            | 11796480                         | 12000000          | +1.70       |
| 361            | 11829248                         | 12000000          | +1.42       |
| 362            | 11862016                         | 12000000          | +1.15       |
| 363            | 11894784                         | 12000000          | +0.88       |
| 364            | 11927552                         | 12000000          | +0.60       |
| 365            | 11960320                         | 12000000          | +0.33       |
| 366            | 11993088                         | 12000000          | +0.06       |
| 367            | 12025856                         | 12000000          | -0.22       |
| 368            | 12058624                         | 12000000          | -0.49       |
| 369            | 12091392                         | 12000000          | -0.76       |
| 370            | 12124160                         | 12000000          | -1.03       |

### RC 24 MHz

| RC12M_CNT[9:0] | External 32.768 kHz Sampled (Hz) | Target Value (Hz) | Tolerance % |
|----------------|----------------------------------|-------------------|-------------|
| 727            | 23822336                         | 24000000          | -0.74       |
| 728            | 23855104                         | 24000000          | -0.6        |
| 729            | 23887872                         | 24000000          | -0.47       |
| 730            | 23920640                         | 24000000          | -0.33       |
| 731            | 23953408                         | 24000000          | -0.19       |
| 732            | 23986176                         | 24000000          | -0.06       |

| RC12M_CNT[9:0] | External 32.768 kHz Sampled (Hz) | Target Value (Hz) | Tolerance % |
|----------------|----------------------------------|-------------------|-------------|
| 733            | 24018944                         | 24000000          | 0.08        |
| 734            | 24051712                         | 24000000          | 0.22        |
| 735            | 24084480                         | 24000000          | 0.35        |
| 736            | 24117248                         | 24000000          | 0.49        |
| 737            | 24150016                         | 24000000          | 0.63        |

**Note:**

1. When WT51F108S/104S is waken up from sleep mode (RC bias is turned on), RC oscillator calibration function needs to wait for at least 83.3ns to return to normal mode.
2. As soon as the RC oscillator calibration function is enabled, read RC12M\_CNT[9:2] & RC12M\_CNT[1:0] register twice, then confirm the data is the same then the calibration can proceed.
3. If RC12M\_CNT[9:0] internal oscillator counter data register is 1023 (0x3FF), indicating that no external oscillator or without enabling external oscillator.
4. When reset, WT51F108S/104S will auto-reload the calibration value of RC 12 MHz into internal oscillator adjustment register (XFR: 0x70).

To switch to RC 24 MHz, **HFIRC\_CLK\_SLT (XFR\_0x01\_bit2)** must be set by program and load the corresponding calibration value.

**IRC Oscillator (12/24M) switching procedures:**

- (a) IRC12M change to IRC24M
    - (1) Set HFIRC\_CLK\_SLT
    - (2) Move flash memory XDATA 0x0E07H-bit[6:0] to XFR\_0x70 register
  - (b) IRC24M change to IRC12M
    - (1) Clear HFIRC\_CLK\_SLT
    - (2) Move flash memory XDATA 0x0E03H-bit[6:0] to XFR\_0x70 register
5. When enable AUTO\_CAL\_EN & the external 32.768 kHz oscillator of MCU is also oscillated, MCU will auto calibrate once every 30.5us.  
(Condition: CRY\_12M\_PD, IRC\_12M\_PD1 & IRC\_12M\_PD2 cannot be turned off).

## 6.9 Watchdog Timer and Watch Timer

### 6.9.1 Watchdog Timer (WDT)

Watchdog Timer can be used to detect CPU failures, such as the software deadlock circles caused by noises, voltage disturbance, or power off etc. When an internal counter of the Watchdog Timer overflows, a reset signal will be generated then reset the CPU.

Watchdog Timer is not similar to the general-purpose 8052 Timer 0/1/2. To prevent a reset occurred on Watchdog Timer, which can be cleared by software before important path of program. When unpredictable reset occurred, user should check the WDT\_RST\_FLG bit in Reset Flag Register to judge if the previous reset is occurred by Watchdog Timer.

- Clock sources of Watchdog Timer: Internal 32 kHz, or External 32.768 kHz Crystal Oscillator
- Reset Time: 16 ms, 32 ms, 1.024 S, 2.048 S

**Watchdog Timer Control Register WDT\_CTL (XFR: 0x78)**

**Reset Value: 02h**

| Bit    | Bit 7        | Bit 6 | Bit 5 | Bit 4    | Bit 3 | Bit 2 | Bit 1           | Bit 0 |
|--------|--------------|-------|-------|----------|-------|-------|-----------------|-------|
| Status | R/W          | R/W   | R/W   | -        | -     | -     | R/W             | R/W   |
| Name   | DIS_WDT[2:0] |       |       | Reserved |       |       | WDT_TM_SLT[1:0] |       |

| Bit Number | Bit Mnemonic    | Description                                                                                                                                                                                                                                                               |
|------------|-----------------|---------------------------------------------------------------------------------------------------------------------------------------------------------------------------------------------------------------------------------------------------------------------------|
| 7-5        | DIS_WDT[2:0]    | Watchdog Timer switch<br>101: Disable Watchdog Timer at the same time clear counts<br>Other value: Enable Watchdog Timer                                                                                                                                                  |
| 4-2        | Reserved        | -                                                                                                                                                                                                                                                                         |
| 1-0        | WDT_TM_SLT[1:0] | Watchdog Reset Time setting<br>When the Watchdog uses internal RC 32 kHz oscillator:<br>00: 16 ms<br>01: 32 ms<br>10: 1.024 S<br>11: 2.048 S<br><br>When the Watchdog uses external 32.768 kHz Crystal Oscillator:<br>00: 15.625 ms<br>01: 31.25 ms<br>10: 1 S<br>11: 2 S |

-: unimplemented.

**Notes:**

1. The frequency tolerance of internal 32 kHz RC oscillator is about  $\pm 30\%$ .
2. The Watchdog Timer clock sources can be selected by the bit WDT\_CLK\_SLT of System Control Register (XFR: 0x01), with details as below.

**System Control Register SYS\_CTL (XFR: 0x01)**
**Reset Value: 80h**

| Bit    | Bit 7   | Bit 6           | Bit 5           | Bit 4        | Bit 3       | Bit 2         | Bit 1       | Bit 0        |
|--------|---------|-----------------|-----------------|--------------|-------------|---------------|-------------|--------------|
| Status | R/W     | R/W             | R/W             | R/W          | R/W         | R/W           | R/W         | R/W          |
| Name   | RST_NDF | LVD_RST_LVL_ADJ | EN_ADDR_OVL_RST | CRY_CLK_DIV2 | BGP_VOL_SLT | HFIRC_CLK_SLT | WDT_CLK_SLT | WTMR_CLK_SLT |

| Bit Number | Bit Mnemonic    | Description                                                                                                                              |
|------------|-----------------|------------------------------------------------------------------------------------------------------------------------------------------|
| 7          | RST_NDF         | 1: NRST pin without digital filter function<br>0: NRST pin with digital filter function (4 clocks)                                       |
| 6          | LVD_RST_LVL_ADJ | 1: +0.25V<br>0: +0V                                                                                                                      |
| 5          | ED_ADDR_OVL_RST | 1: Enable "PC Counter Overflow Reset"<br>0: Disable "PC Counter Overflow Reset"                                                          |
| 4          | CRY_CLK_DIV2    | 1: Enable "External Crystal Oscillator Prescaler" /2<br>0: Disable "External Crystal Oscillator Prescaler"                               |
| 3          | BGP_VOL_SLT     | 1: BandGap = 2.44V<br>0: BandGap = 1.23V                                                                                                 |
| 2          | HFIRC_CLK_SLT   | 1: Internal IRC oscillator = 24 MHz<br>0: Internal IRC oscillator = 12 MHz                                                               |
| 1          | WDT_CLK_SLT     | <b>1: Watchdog Timer uses external 24 MHz ~ 32 kHz crystal oscillator</b><br><b>0: Watchdog Timer uses internal 32 kHz RC oscillator</b> |
| 0          | WTMR_CLK_SLT    | 1: Watch Timer uses external 24 MHz ~ 32 kHz crystal oscillator<br>0: Watch Timer uses internal 32 kHz RC oscillator                     |

-: unimplemented.

**Note: If WDT\_CLK\_SLT = 1 or WTMR\_CLK\_SLT = 1, must enable EN\_CRY\_DIV and set CRY\_DIV[9:0] at the same time, and let the Watchdog Timer and Watch Timer use the precise clock source 32 kHz.**

**External Clock Source Prescaler Control Register 1 CRY\_DIV[9:8] (XFR: 0x09)**
**Reset Value: 01h**

| Bit    | Bit 7      | Bit 6    | Bit 5 | Bit 4 | Bit 3 | Bit 2 | Bit 1        | Bit 0 |
|--------|------------|----------|-------|-------|-------|-------|--------------|-------|
| Status | R/W        | -        | -     | -     | -     | -     | R/W          | R/W   |
| Name   | EN_CRY_DIV | Reserved |       |       |       |       | CRY_DIV[9:8] |       |

| Bit Number | Bit Mnemonic | Description                                                                                                                                 |
|------------|--------------|---------------------------------------------------------------------------------------------------------------------------------------------|
| 7          | EN_CRY_DIV   | 1: Enable the clock source prescaler of external crystal oscillator<br>0: Disable the clock source prescaler of external crystal oscillator |
| 6-2        | Reserved     | -                                                                                                                                           |
| 1-0        | CRY_DIV[9:8] | The prescaler data [9:8] of external Crystal Oscillator Clock source, is paired with CRY_DIV[7:0] to form a 10-bit prescaler data           |

-: unimplemented.



**External Clock Source Prescaler Control Register 2 CRY\_DIV[7:0] (XFR: 0x0A)**
**Reset Value: 76h**

|        |              |       |       |       |       |       |       |       |
|--------|--------------|-------|-------|-------|-------|-------|-------|-------|
| Bit    | Bit 7        | Bit 6 | Bit 5 | Bit 4 | Bit 3 | Bit 2 | Bit 1 | Bit 0 |
| Status | R/W          | R/W   | R/W   | R/W   | R/W   | R/W   | R/W   | R/W   |
| Name   | CRY_DIV[7:0] |       |       |       |       |       |       |       |

| Bit Number | Bit Mnemonic | Description                                                                                                                       |
|------------|--------------|-----------------------------------------------------------------------------------------------------------------------------------|
| 7-0        | CRY_DIV[7:0] | The prescaler data [7:0] of external Crystal Oscillator Clock source, is paired with CRY_DIV[9:8] to form a 10-bit prescaler data |

**Examples:**

1. If the clock source is External 12 MHz crystal oscillator, and the Watchdog Timer and Watch Timer use the clock source with low tolerance frequency (for precise time base), then the External Clock Source Prescaler Control Register must be enabled and the prescaler data is required.
  1. Setting prescaler data:  $CRY\_DIV[9:0] = 374$ ;  $12\text{ MHz} / (CRY\_DIV[9:0] + 1) = 12\text{ MHz}/375 = 32\text{ kHz}$
  2. Enable clock source prescaler of external crystal oscillator:  $EN\_CRY\_DIV = 1$
  
2. If the clock source is External 32.768 kHz crystal oscillator, and the Watchdog Timer and Watch Timer use the clock source with low tolerance frequency (for precise time base), then the External Clock Source Prescaler Control Register must be enabled and the prescaler data is required.
  1. Setting prescaler data:  $CRY\_DIV[9:0] = 0$ ;  $32.768\text{ kHz}/(CRY\_DIV[9:0] + 1) = 32.768\text{ kHz}/1 = 32.768\text{ kHz}$
  2. Enable clock source prescaler of external crystal oscillator:  $EN\_CRY\_DIV = 1$

## 6.9.2 Watch Timer

The application functions of Watch Timer include Timer Interrupt, Timer Wakeup, Timer ADC and so on.

- The clock source of Watch Timer is 32 kHz internal RC oscillator or 32.768 kHz external oscillator. By this clock, it can generate eight Time bases

### Watch Timer Control Register WTMR\_CTL (XFR: 0x7C)

Reset Value: 80h

| Bit    | Bit 7    | Bit 6    | Bit 5        | Bit 4    | Bit 3 | Bit 2 | Bit 1 | Bit 0 |
|--------|----------|----------|--------------|----------|-------|-------|-------|-------|
| Status | R/W      | R        | W            | -        | -     | -     | -     | -     |
| Name   | DIS_WTMR | WTMR_EVT | CLR_WTMR_EVT | Reserved |       |       |       |       |

| Bit Number | Bit Mnemonic | Description                                                                                                                       |
|------------|--------------|-----------------------------------------------------------------------------------------------------------------------------------|
| 7          | DIS_WTMR     | 1: Disable Watch Timer<br>0: Enable Watch Timer                                                                                   |
| 6          | WTMR_EVT     | 1: Indicates Watch Timer Event (the setting time of Watch Timer as the count reaches WTMR[2:0])<br>0: Cleared by CLR_WTMR_EVT = 1 |
| 5          | CLR_WTMR_EVT | 1: Clear Watch Timer event, and then WTMR_EVT = 0                                                                                 |
| 4-0        | Reserved     | -                                                                                                                                 |

-: unimplemented.

### Watch Timer Output Selection Register WTMR\_SLT[2:0] (XFR: 0x7D)

Reset Value: 00h

| Bit    | Bit 7    | Bit 6 | Bit 5 | Bit 4 | Bit 3 | Bit 2         | Bit 1 | Bit 0 |
|--------|----------|-------|-------|-------|-------|---------------|-------|-------|
| Status | -        | -     | -     | -     | -     | R/W           | R/W   | R/W   |
| Name   | Reserved |       |       |       |       | WTMR_SLT[2:0] |       |       |

| Bit Number | Bit Mnemonic  | Description                                                                                                                                                                                                                                                                                                                                                                                          |
|------------|---------------|------------------------------------------------------------------------------------------------------------------------------------------------------------------------------------------------------------------------------------------------------------------------------------------------------------------------------------------------------------------------------------------------------|
| 7-3        | Reserved      | -                                                                                                                                                                                                                                                                                                                                                                                                    |
| 2-0        | WTMR_SLT[2:0] | Watch Timer Time base selection bit<br>(If needs to be precise, using external Crystal Oscillator 12 MHz or 32.768 kHz is recommended, please refer to section 6.9.1.)<br>000: Watch time = 3.91 ms<br>001: Watch time = 31.25 ms<br>010: Watch time = 62.50 ms<br>011: Watch time = 125 ms<br>100: Watch time = 0.25 S<br>101: Watch time = 0.5 S<br>110: Watch time = 1 S<br>111: Watch time = 2 S |

-: unimplemented.

## 6.10 I<sup>2</sup>C Serial Interface

I<sup>2</sup>C module uses SCL (clock) and SDA (data) wires to connect with other I<sup>2</sup>C interfaces.

### Slave I<sup>2</sup>C Control Register SI<sup>2</sup>C\_CTL (XFR: 0xA0)

Reset Value: 40h

| Bit    | Bit 7                | Bit 6    | Bit 5 | Bit 4 | Bit 3 | Bit 2                  | Bit 1                    | Bit 0                     |
|--------|----------------------|----------|-------|-------|-------|------------------------|--------------------------|---------------------------|
| Status | R/W                  | -        | -     | -     | -     | R/W                    | W                        | W                         |
| Name   | SI <sup>2</sup> C_EN | Reserved |       |       |       | S <sup>2</sup> C_TXNAK | SI <sup>2</sup> C_CLR_RT | SI <sup>2</sup> C_CLR_STP |

| Bit Number | Bit Mnemonic              | Description                                                                                          |
|------------|---------------------------|------------------------------------------------------------------------------------------------------|
| 7          | SI <sup>2</sup> C_EN      | 1: Enable I <sup>2</sup> C function<br>0: Disable I <sup>2</sup> C function                          |
| 6-3        | Reserved                  | Must be set as 0                                                                                     |
| 2          | SI <sup>2</sup> C_TXNAK   | I <sup>2</sup> C Transmit ACK bit after next Rx state<br>Bit 1: Transmit NACK<br>Bit 0: Transmit ACK |
| 1          | SI <sup>2</sup> C_CLR_RT  | 1: Clear Transmit and Receive interrupt                                                              |
| 0          | SI <sup>2</sup> C_CLR_STP | 1: Clear Slave mode Stop status interrupt                                                            |

### Master/Slave I<sup>2</sup>C Status Register SI<sup>2</sup>C\_STA (XFR: 0xA1)

Reset Value: 00h

| Bit    | Bit 7                 | Bit 6                    | Bit 5                      | Bit 4                | Bit 3                   | Bit 2                | Bit 1                   | Bit 0                  |
|--------|-----------------------|--------------------------|----------------------------|----------------------|-------------------------|----------------------|-------------------------|------------------------|
| Status | R                     | R                        | R                          | R                    | R                       | R                    | R                       | R/W                    |
| Name   | SI <sup>2</sup> C_RDY | SI <sup>2</sup> C_INT_RT | SI <sup>2</sup> C_INT_STOP | SI <sup>2</sup> C_BB | SI <sup>2</sup> C_FIRST | SI <sup>2</sup> C_RW | SI <sup>2</sup> C_RXNAK | SI <sup>2</sup> C_WAIT |

| Bit Number | Bit Mnemonic               | Description                                                                                                                                                                      |
|------------|----------------------------|----------------------------------------------------------------------------------------------------------------------------------------------------------------------------------|
| 7          | SI <sup>2</sup> C_RDY      | When bit = 1, Interrupt status when I <sup>2</sup> C Receive/Transmit the 9 <sup>th</sup> bit or Slave Stop phase                                                                |
| 6          | SI <sup>2</sup> C_INT_RT   | When bit = 1, Interrupt status when I <sup>2</sup> C Receive/Transmit the 9 <sup>th</sup> bit                                                                                    |
| 5          | SI <sup>2</sup> C_INT_STOP | When bit = 1, Interrupt status when I <sup>2</sup> C Slave mode Stop phase                                                                                                       |
| 4          | SI <sup>2</sup> C_BB       | When bit = 1, Slave mode bus busy                                                                                                                                                |
| 3          | SI <sup>2</sup> C_FIRST    | Slave mode First phase.<br>This is the first byte from Master I <sup>2</sup> C with specific Slave Address.                                                                      |
| 2          | SI <sup>2</sup> C_RW       | When bit = 1, Slave mode Read/Write Phase (the 8 <sup>th</sup> bit of the first byte)<br>1: Slave I <sup>2</sup> C as Transmit mode<br>0: Slave I <sup>2</sup> C as Receive mode |
| 1          | SI <sup>2</sup> C_RXNAK    | ACK bit indicator when I <sup>2</sup> C in Slave Tx mode<br>1: Master mode return NACK<br>0: Master mode return ACK                                                              |
| 0          | SI <sup>2</sup> C_WAIT     | 1: Enable pull low SCL when 9 <sup>th</sup> SCL bit<br>0: Disable pull low SCL when 9 <sup>th</sup> SCL bit                                                                      |

:- unimplemented.

If the firmware processing time is slower than the time of I<sup>2</sup>C receiving 9 bits, then the firmware must set MI<sup>2</sup>C\_WAIT enabling WT51F108S/104S to pull SCL low after the 9<sup>th</sup> bit.

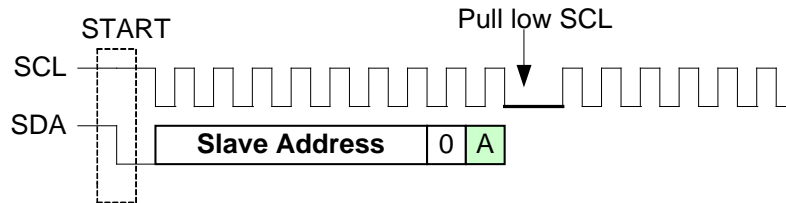

**Master/Slave I<sup>2</sup>C Transmit and Receive Buffer Register MI<sup>2</sup>C\_DTRX[7:0] (XFR: 0xA3) Reset Value: FFh**

|        |                             |       |       |       |       |       |       |       |
|--------|-----------------------------|-------|-------|-------|-------|-------|-------|-------|
| Bit    | Bit 7                       | Bit 6 | Bit 5 | Bit 4 | Bit 3 | Bit 2 | Bit 1 | Bit 0 |
| Status | R/W                         | R/W   | R/W   | R/W   | R/W   | R/W   | R/W   | R/W   |
| Name   | SI <sup>2</sup> C_DTRX[7:0] |       |       |       |       |       |       |       |

| Bit Number | Bit Mnemonic                | Description                                                                                                                                               |
|------------|-----------------------------|-----------------------------------------------------------------------------------------------------------------------------------------------------------|
| 7-0        | SI <sup>2</sup> C_DTRX[7:0] | I <sup>2</sup> C transmit and receive buffer<br>W: When Tx work as I <sup>2</sup> C transmit buffer<br>R: When Rx work as I <sup>2</sup> C receive buffer |

**Slave I<sup>2</sup>C Address Register SI<sup>2</sup>C\_SADR (XFR: 0xA4)**

**Reset Value: 00h**

|        |                        |       |       |       |       |       |       |          |
|--------|------------------------|-------|-------|-------|-------|-------|-------|----------|
| Bit    | Bit 7                  | Bit 6 | Bit 5 | Bit 4 | Bit 3 | Bit 2 | Bit 1 | Bit 0    |
| Status | R/W                    | R/W   | R/W   | R/W   | R/W   | R/W   | R/W   | -        |
| Name   | SI <sup>2</sup> C_SADR |       |       |       |       |       |       | Reserved |

| Bit Number | Bit Mnemonic           | Description       |
|------------|------------------------|-------------------|
| 7-1        | SI <sup>2</sup> C_SADR | The slave address |
| 0          | Reserved               | -                 |

-: unimplemented.

**WT51F108S/104S Slave I<sup>2</sup>C Data Flow**

**Slave IIC Data Flow**

**(1) IIC write mode :**

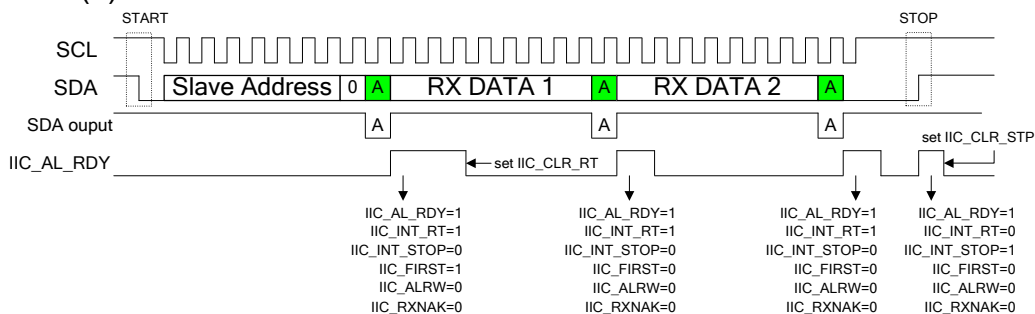

**(2) IIC read mode :**

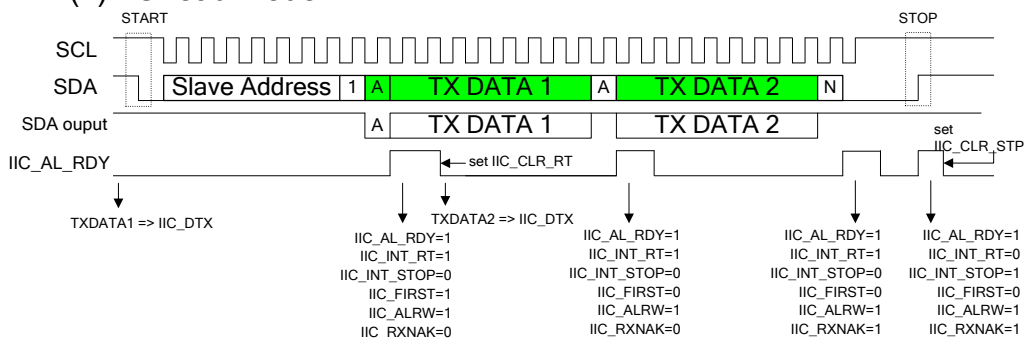

**WT51F108S/104S Slave I<sup>2</sup>C Data Flow**

**Slave IIC Flow Chart**

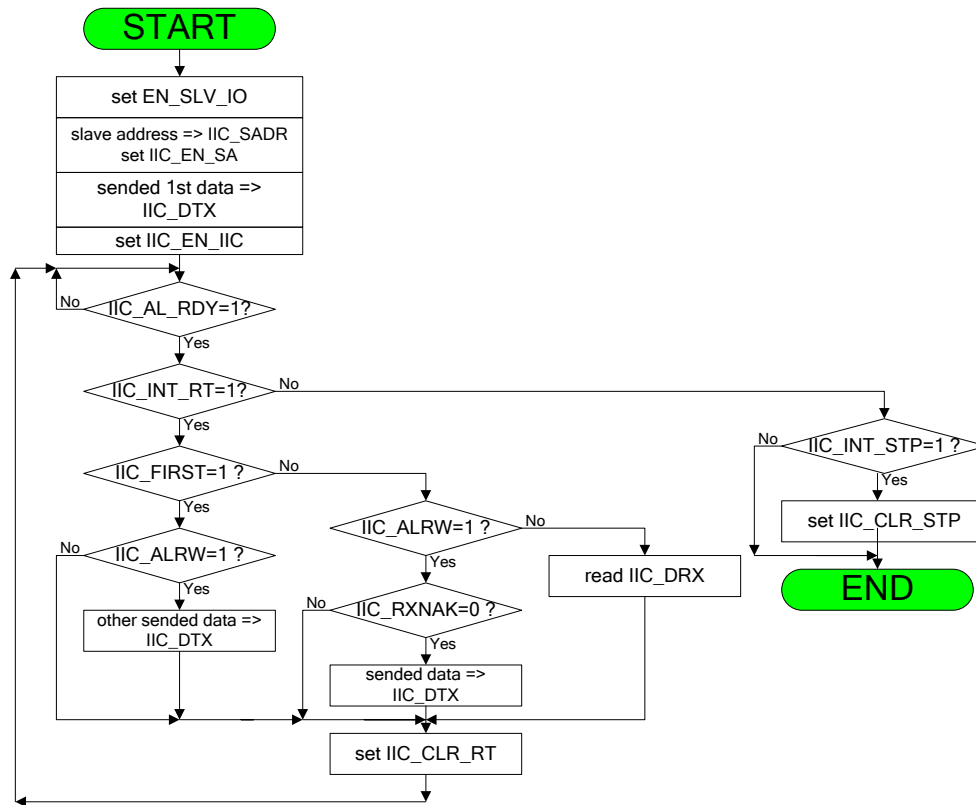

## 6.11 Enhanced Timer/Counter

The clock sources of enhanced Timer/Counter are from internal or external clock, and it is determined by register. The Enhanced Timer/Counter has two operation modes: 1. Compare mode. 2. Capture mode. Furthermore there are three types of Capture Match condition for selection: High-level, Low-level, and Period of Capture mode.

### 1. Compare mode:

The Enhanced Timer/Counter contains one 16-bit Counter and one 16-bit enhanced Buffer (ETM\_BUF[15:0]). When enable the Enhanced Timer/Counter (EN\_ETM = 1) and set as the compare mode (ETM\_CNT\_TM = 1), the counter will start counts according to the clock sources, and an interrupt will occur once the data of the counter matches the data of the enhanced Buffer. Each match will output the trigger of ETMO (function not available) and clear the counter value of the internal 16-bit Counter. Please refer to the figure below.

Compare mode operation flow:

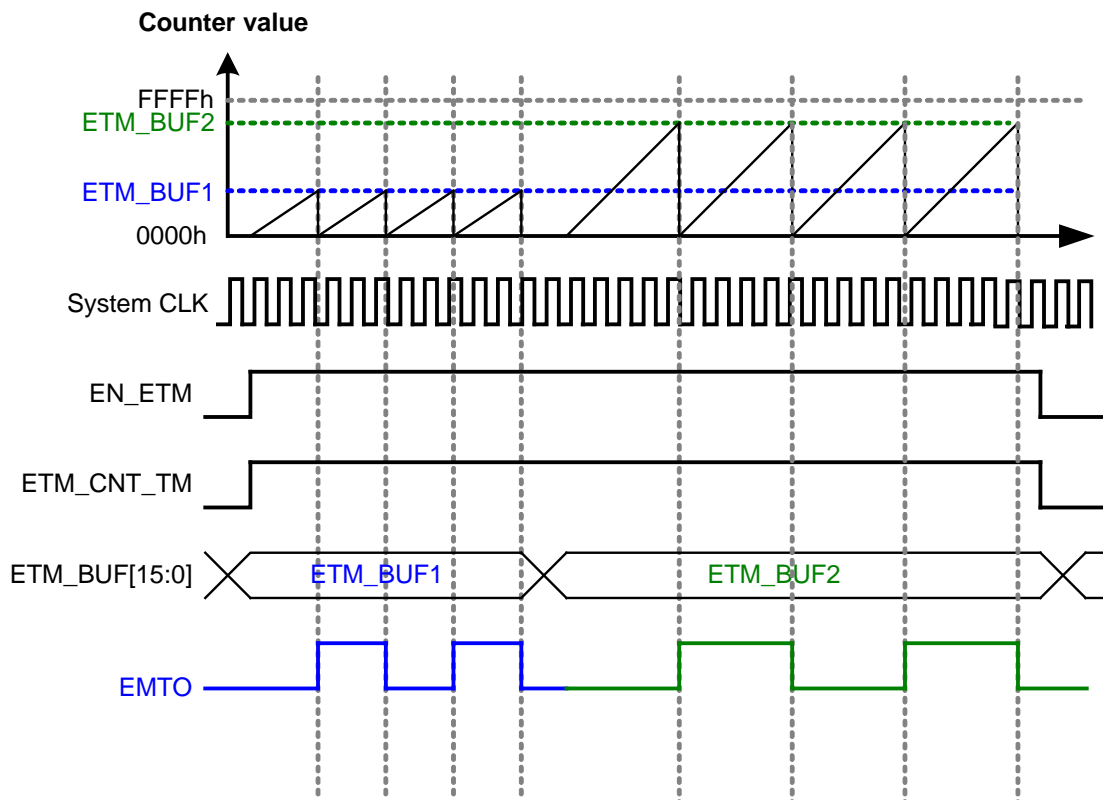

## 2. Capture mode:

If the Enhanced Timer/Counter is set as the Capture mode (ETM\_CNT\_TM = 0), and it is enabled (EN\_ETM = 1), the capture operation starts. When the input status changes then match with the setting capture condition, the internal 16-bit counter will be cleared and restarts counting, then reload the counter value into 16-bit Buffer (ETM\_BUF[15:0]) automatically. At the same time, the software can read the counter value from the Enhanced Timer/Counter Data Buffer Register (register B3H & B4H), and a capture interrupt, capture flag and output ETM0 may be generated (function not available). Please refer to the figure below.

### Capture mode operation flow:

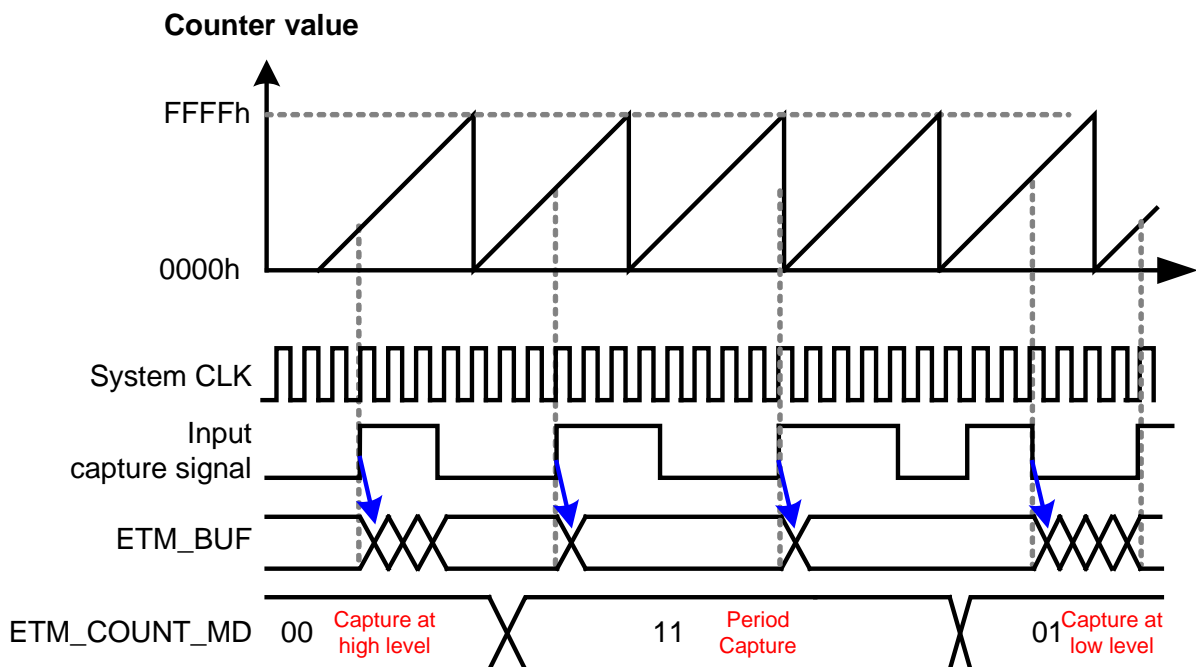

### Enhanced Timer/Counter Control Register 1 ETM\_CTL1 (XFR: 0xB0)

Reset Value: 00h

| Bit    | Bit 7  | Bit 6      | Bit 5              | Bit 4 | Bit 3       | Bit 2              | Bit 1 | Bit 0         |
|--------|--------|------------|--------------------|-------|-------------|--------------------|-------|---------------|
| Status | R/W    | R/W        | R/W                | R/W   | R/W         | R/W                | R/W   | R/W           |
| Name   | EN_ETM | ETM_CNT_TM | ETM_CLK_PSCAL[1:0] |       | ETM_CLK_SEL | ETM_EXCLK_SEL[1:0] |       | ETM_CLK_DIV12 |

| Bit Number | Bit Mnemonic | Description                                                          |
|------------|--------------|----------------------------------------------------------------------|
| 7          | EN_ETM       | 1: Enable Enhanced Timer/Counter                                     |
| 6          | ETM_CNT_TM   | 1: Compare mode (SOURCE clock = 12 MHz)<br>0: Capture mode (capture) |



| Bit Number | Bit Mnemonic       | Description                                                                                                                                                                                                                                                                                                                                                                                               |
|------------|--------------------|-----------------------------------------------------------------------------------------------------------------------------------------------------------------------------------------------------------------------------------------------------------------------------------------------------------------------------------------------------------------------------------------------------------|
| 5-4        | ETM_CLK_PSCAL[1:0] | Set clock source prescalers of the internal 16-bit Counter<br>00: Enhanced Timer/Counter clock source = SOURCE clock/1<br>01: Enhanced Timer/Counter clock source = SOURCE clock/4<br>10: Enhanced Timer/Counter clock source = SOURCE clock/8<br>11: Choose Timer/Counter clock base SOURCE clock/16 or SOURCE clock/12<br>(ETM_CLK_DIV12: 0 -> SOURCE clock/16;<br>ETM_CLK_DIV12: 1 -> SOURCE clock/12) |
| 3          | ETM_CLK_SEL        | Set Enhanced Timer/Counter clock source<br>1: External clock source (can select the input clock source by ETM_EXCLK_SEL[1:0])<br>0: Internal clock source (SOURCE clock)                                                                                                                                                                                                                                  |
| 2-1        | ETM_EXCLK_SEL[1:0] | Set Enhanced Timer/Counter input external clock source channel<br>00: GPIOA4 (set GPIOA4DH as GPIO input, GPA4_FUN_SLT[2:0] = 000)<br>01: GPIOA3 (set GPIOA3D as GPIO input, GPA3_FUN_SLT[2:0] = 000)<br>10: GPIOA2 (set GPIOA2DH as GPIO input, GPA2_FUN_SLT[2:0] = 000)<br>11: GPIOA5 (set GPIOA5DH as GPIO input, GPA5_FUN_SLT[2:0] = 000)                                                             |
| 0          | ETM_CLK_DIV12      | 1: SOURCE clock/12<br>0: SOURCE clock/16                                                                                                                                                                                                                                                                                                                                                                  |

-: unimplemented.

**Note:** If the external clock source channel of the Enhanced Timer/Counter input is one of the GPIOA5, GPIOA4, GPIOA3, or GPIOA2, and then the GPIO complex function must be set as GPIO and I/O port being input status.

**Enhanced Timer/Counter Control Register 2 ETM\_CTL2 (XFR: 0xB1)**
**Reset Value: 00h**

| Bit    | Bit 7              | Bit 6 | Bit 5    | Bit 4 | Bit 3             | Bit 2 | Bit 1             | Bit 0 |
|--------|--------------------|-------|----------|-------|-------------------|-------|-------------------|-------|
| Status | R/W                | R/W   | -        | -     | R/W               | R/W   | R/W               | R/W   |
| Name   | ETM_IN_SOURCE[1:0] |       | Reserved |       | ETM_IN_PSCAL[1:0] |       | ETM_COUNT_MD[1:0] |       |

| Bit Number | Bit Mnemonic       | Description                                                                                                                                                                                                                                                                                                                                |
|------------|--------------------|--------------------------------------------------------------------------------------------------------------------------------------------------------------------------------------------------------------------------------------------------------------------------------------------------------------------------------------------|
| 7-6        | ETM_IN_SOURCE[1:0] | Set Enhanced Timer/Counter input compare or capture channel<br>00: GPIOA4 (set GPIOA4DH as GPIO input, GPA4_FUN_SLT[2:0] = 000)<br>01: GPIOA3 (set GPIOA3D as GPIO input, GPA3_FUN_SLT[2:0] = 000)<br>10: GPIOA2 (set GPIOA2DH as GPIO input, GPA2_FUN_SLT[2:0] = 000)<br>11: GPIOA5 (set GPIOA5DH as GPIO input, GPA5_FUN_SLT[2:0] = 000) |
| 5-4        | Reserved           | -                                                                                                                                                                                                                                                                                                                                          |
| 3-2        | ETM_IN_PSCAL[1:0]  | Set input channel period prescaler<br>00: Input period/1<br>01: Input period/4                                                                                                                                                                                                                                                             |

| Bit Number | Bit Mnemonic      | Description                                                                                                                                                                                               |
|------------|-------------------|-----------------------------------------------------------------------------------------------------------------------------------------------------------------------------------------------------------|
|            |                   | 10: Input period/8<br>11: Input period/16                                                                                                                                                                 |
| 1-0        | ETM_COUNT_MD[1:0] | Capture counting mode selection<br>00: Capture the interval of high level<br>01: Capture the interval of low level<br>1x: Capture the interval period (based on the setting ETM_IN_PSCAL[1:0] to capture) |

-: unimplemented.

**Note:** If the external clock source channel of the Enhanced Timer/Counter input is one of the GPIOA5, GPIOA4, GPIOA3, or GPIOA2, and then the GPIO complex function must be set as GPIO and I/O port being input status.

**Enhanced Timer/Counter Interrupt Register ETM\_INT (XFR: 0xB2)**
**Reset Value: 00h**

| Bit    | Bit 7     | Bit 6     | Bit 5     | Bit 4    | Bit 3 | Bit 2 | Bit 1 | Bit 0    |
|--------|-----------|-----------|-----------|----------|-------|-------|-------|----------|
| Status | R/W       | R/W       | R/W       | R/W      | R     | R     | R     | -        |
| Name   | EN_CAPINT | EN_OVRINT | EN_CMPINT | CLR_FLAG | CAPF  | OVRF  | CPMF  | Reserved |

| Bit Number | Bit Mnemonic | Description                                                                                |
|------------|--------------|--------------------------------------------------------------------------------------------|
| 7          | EN_CAPINT    | 1: Enable input capture interrupt<br>0: Disable input capture interrupt                    |
| 6          | EN_OVRINT    | 1: Enable overflow interrupt<br>0: Disable overflow interrupt                              |
| 5          | EN_CMPINT    | 1: Enable Compare Match Interrupt<br>0: Disable Compare Match Interrupt                    |
| 4          | CLR_FLAG     | 1: Clear all Enhanced Timer/Counter flags                                                  |
| 3          | CAPF         | Input capture flag                                                                         |
| 2          | OVRF         | Overflow flag<br>When an overflow occurred in internal 16-bit counter, OVRF = 1            |
| 1          | CPMF         | Compare match flag<br>When internal 16-bit counter has the same value as ETM_BUF, CPMF = 1 |
| 0          | Reserved     | -                                                                                          |

-: unimplemented.

**Enhanced Timer/Counter Data Buffer Low Bytes Register ETM\_BUF[7:0] (XFR: 0xB3)**
**Reset Value: 00h**

| Bit    | Bit 7        | Bit 6 | Bit 5 | Bit 4 | Bit 3 | Bit 2 | Bit 1 | Bit 0 |
|--------|--------------|-------|-------|-------|-------|-------|-------|-------|
| Status | R/W          | R/W   | R/W   | R/W   | R/W   | R/W   | R/W   | R/W   |
| Name   | ETM_BUF[7:0] |       |       |       |       |       |       |       |

| Bit Number | Bit Mnemonic | Description                                                                                                                                                                                           |
|------------|--------------|-------------------------------------------------------------------------------------------------------------------------------------------------------------------------------------------------------|
| 7-0        | ETM_BUF[7:0] | Paired with ETM_BUF[15:8] to form a 16-bit counter value<br>Read: In Capture mode, the counter value of the captured input signal<br>Write: In Compare mode, as the compare value to compare with the |

| Bit Number | Bit Mnemonic | Description             |
|------------|--------------|-------------------------|
|            |              | internal 16-bit counter |

**Enhanced Timer/Counter Data Buffer High Bytes Register ETM\_BUF[15:8] (XFR: 0xB4) Reset Value: 80h**

| Bit    | Bit 7         | Bit 6 | Bit 5 | Bit 4 | Bit 3 | Bit 2 | Bit 1 | Bit 0 |
|--------|---------------|-------|-------|-------|-------|-------|-------|-------|
| Status | R/W           | R/W   | R/W   | R/W   | R/W   | R/W   | R/W   | R/W   |
| Name   | ETM_BUF[15:8] |       |       |       |       |       |       |       |

| Bit Number | Bit Mnemonic  | Description                                                                                                                                                                                                                  |
|------------|---------------|------------------------------------------------------------------------------------------------------------------------------------------------------------------------------------------------------------------------------|
| 7-0        | ETM_BUF[15:8] | Paired with ETM_BUF[7:0] to form a 16-bit counter value<br>Read: In Capture mode, the counter value of the captured input signal<br>Write: In Compare mode, as the compare value to compare with the internal 16-bit counter |

**Note:** In Capture mode, ETM\_BUF[15:8] and ETM\_BUF[7:0] form a 16-bit counter value, and the counter value should be incremented by one to be the actual counter value in application.

**Explanation 1:**

Due to the internal source goes through the filter, the pulse width of input signal high level and low level must be greater than the width of two SYSTEM Clocks.

**Explanation 2:**

**ETM\_IN\_PSCAL[3:2] = 00:** Select Capture Input Source 1 cycle, then the Capture effective Resolution is as below:

If Source Clock = 12 MHz,  $(1/12 \text{ MHz})/1 = 83.333 \text{ ns}$ ;

If Source Clock = 24 MHz,  $(1/24 \text{ MHz})/1 = 41.666 \text{ ns}$ .

**ETM\_IN\_PSCAL[3:2] = 11:** Select Capture Input Source 16 cycles, then the Capture effective Resolution is as below:

If Source Clock = 12 MHz,  $(1/12 \text{ MHz})/16 = 5.208 \text{ ns}$ ;

If Source Clock = 24 MHz,  $(1/24 \text{ MHz})/16 = 2.604 \text{ ns}$ .

When select Capture 16 cycles allow the enhanced Timer/Counter to get more significant digits, to reduce capture error.

## 6.12 Analog/Digital Converter (ADC)

WT51F108S/104S has a built-in 16-channel 10-bit Analog/Digital Converter, and it also provides four conversion modes (Single, Continuous, Voltage Compare, and Timer Auto mode) and four conversion rate (1 MHz, 500 kHz, 125 kHz, and 31.25 kHz) for selection.

- The conversion time of A/D Converter is 16us (sampled time 6 us + conversion time 10 us) based on the conversion rate of 1 MHz
- Reference Voltage sources VREF have three selections: Power Voltage VDD, Built-in voltage reference VBGAP, and External voltage reference VREF

### Single Mode:

Turn on the A/D converter power (XFR: 0xD0 ADC\_CTL, and ADC\_PD = 0), and set the ADC\_SINGLE\_CVT = 1, then the A/D conversion starts. When ADC\_SINGLE\_CVT = 0, the conversion is finished. When conversion is completed, the conversion data will be updated and an interrupt will generate (ADFINSH\_FLG = 1). If ADC convert finish Interrupt is enabled (EN\_ADFINSH\_INT = 1), the ADC interrupt will generate.

### Continuous Mode:

If activate continuous convert control bit ADC\_CNTNU\_CVT = 1, the system will enter the Continuous Conversion Mode.

### Voltage Compare Mode:

When turn on the A/D converter power (XFR: 0xD0 ADC\_CTL, and ADC Control Register ADC\_PD = 0), and activate the Compare function (EN\_ADC\_CMP = 1), the conversion data of Analog input compare 10-bit setting of XFR: 0xD4 & 0xD5 (ADC\_CMP\_V). When the corresponding digital value of the voltage analog input is greater than (ADC\_BIG = 0) or smaller than (ADC\_BIG = 1) the setting value of ADC\_CMP\_V register, the ADC interrupt will occur. The Voltage Compare function of A/D Converter module worked as a wakeup source. In addition, working together with XFR: 0xD1 ADC\_SEL & ADCMP\_TM to define ADC turn on time for power-saving purpose.

### Timer Auto Mode:

When turn on the ADC\_AUTO\_CVT and work together with the setting of Watch Timer, each Timer event will automatically activate ADC for one-time conversion.

**ADC Control Register ADC\_CTL (XFR: 0xD0)**
**Reset Value: 80h**

|        |        |                |               |              |            |            |          |         |
|--------|--------|----------------|---------------|--------------|------------|------------|----------|---------|
| Bit    | Bit 7  | Bit 6          | Bit 5         | Bit 4        | Bit 3      | Bit 2      | Bit 1    | Bit 0   |
| Status | R/W    | R/W            | R/W           | R/W          | R/W        | R/W        | -        | R/W     |
| Name   | ADC_PD | ADC_SINGLE_CVT | ADC_CNTNU_CVT | ADC_AUTO_CVT | EN_ADC_CMP | EN_ADC_FLT | Reserved | ADC_BIG |

| Bit Number | Bit Mnemonic   | Description                                                                                                                                                                             |
|------------|----------------|-----------------------------------------------------------------------------------------------------------------------------------------------------------------------------------------|
| 7          | ADC_PD         | Analog/Digital Converter Power Control<br>1: Turn off ADC power<br>0: Turn on ADC power                                                                                                 |
| 6          | ADC_SINGLE_CVT | ADC start convert bit (single convert mode)<br>1: ADC start convert<br>1 => 0: convert finished (hardware will be auto-cleared as "0")                                                  |
| 5          | ADC_CNTNU_CVT  | 1: Enable ADC continuous convert (continuous convert mode)<br>0: Disable ADC continuous convert                                                                                         |
| 4          | ADC_AUTO_CVT   | 1: Enable ADC auto convert one time based on Watch Timer event WTMR_SLT[2:0] (Timer Compare mode)                                                                                       |
| 3          | EN_ADC_CMP     | 1: Enable ADC compare mode (Voltage compare mode)                                                                                                                                       |
| 2          | EN_ADC_FLT     | 1: Enable ADC filter (need to wait for 332nsec)<br>0: Disable filter function                                                                                                           |
| 1          | Reserved       | -                                                                                                                                                                                       |
| 0          | ADC_BIG        | ADC data compare flag<br>1: The data is set when $V_{in} < ADC\_CMP\_V[9:0]$<br>0: The data is set when $V_{in} > ADC\_CMP\_V[9:0]$<br>$V_{in}$ : The channel is selected by EN_AD[3:0] |

**Note: Only one converting mode is allowed to enable the ADC at the same time, otherwise ADC may work abnormally.**

**ADC Setting Control Register ADC\_SEL (XFR: 0xD1)**
**Reset Value: 40h**

|        |                  |       |          |          |       |       |                   |       |
|--------|------------------|-------|----------|----------|-------|-------|-------------------|-------|
| Bit    | Bit 7            | Bit 6 | Bit 5    | Bit 4    | Bit 3 | Bit 2 | Bit 1             | Bit 0 |
| Status | R/W              | R/W   | R/W      | -        | -     | -     | R/W               | R/W   |
| Name   | ADC_CLK_SEL[1:0] |       | ADCMP_TM | Reserved |       |       | ADC_VREF_SEL[1:0] |       |

| Bit Number | Bit Mnemonic      | Description                                                                                                                                          |          |                                                                                                                             |
|------------|-------------------|------------------------------------------------------------------------------------------------------------------------------------------------------|----------|-----------------------------------------------------------------------------------------------------------------------------|
| 7          | ADC_CLK_SEL[1:0]  | ADC convert time clock base<br>00: 1 MHz (MCU_Clock/12)<br>01: 500 kHz (MCU_Clock/24)<br>10: 125 kHz (MCU_Clock/96)<br>11: 31.25 kHz (MCU_Clock/384) |          |                                                                                                                             |
| 6          |                   |                                                                                                                                                      |          |                                                                                                                             |
| 5          |                   |                                                                                                                                                      | ADCMP_TM | 1: Turn on 32 us ADC compare function by Watch Timer at every 32 ms for power-saving purpose.<br>0: ADC always compare time |
| 4-2        |                   |                                                                                                                                                      | Reserved | -                                                                                                                           |
| 1-0        | ADC_VREF_SEL[1:0] | ADC reference voltage selection<br>00: From VDD                                                                                                      |          |                                                                                                                             |

| Bit Number | Bit Mnemonic | Description                                                             |
|------------|--------------|-------------------------------------------------------------------------|
|            |              | 01: From VREF pin<br>1x: From internal reference voltage BGAP (Bandgap) |

-: unimplemented.

**Note:** Internal reference voltage Bandgap setting, please refer to section 6.19. Regarding the detailed Electrical Characteristics, please refer to section 7.6 & 7.7.

**ADC Interrupt Control Register ADC\_INT (XFR: 0xD2)**
**Reset Value: 00h**

| Bit    | Bit 7        | Bit 6          | Bit 5    | Bit 4 | Bit 3         | Bit 2       | Bit 1     | Bit 0    |
|--------|--------------|----------------|----------|-------|---------------|-------------|-----------|----------|
| Status | R/W          | R/W            | -        | -     | R             | R           | R         | -        |
| Name   | EN_ADCMP_INT | EN_ADFINSH_INT | Reserved |       | ADCMP_EDG_FLG | ADFINSH_FLG | ADCMP_FLG | Reserved |

| Bit Number | Bit Mnemonic   | Description                                                                                                    |
|------------|----------------|----------------------------------------------------------------------------------------------------------------|
| 7          | EN_ADCMP_INT   | 1: Enable ADC Compare Interrupt<br>0: Disable ADC Compare Interrupt                                            |
| 6          | EN_ADFINSH_INT | 1: Enable ADC Convert Finish Interrupt<br>0: Disable ADC Convert Finish Interrupt                              |
| 5-4        | Reserved       | -                                                                                                              |
| 3          | ADCMP_EDG_FLG  | ADC Compare Mode Flag. If the condition selected by ADC_BIG bit in ADC Control Register is met, ADCMP_FLG = 1. |
| 2          | ADFINSH_FLG    | ADC Finish Interrupt Flag (If the ADC finished convert in single, continuous or timer mode, ADFINSH_FLG = 1)   |
| 1          | ADCMP_FLG      | 1: $V_{in} > ADC\_CMP\_V[9:0]$<br>0: $V_{in} < ADC\_CMP\_V[9:0]$                                               |
| 0          | Reserved       | -                                                                                                              |

-: unimplemented.

**Note:** When reading AD\_DATA[9:0], the hardware will automatically clear the ADCMP\_FLG and ADFINSH\_FLG flags.

**ADC Channel Control Register ADC\_ENCH (XFR: 0xD3)**
**Reset Value: 00h**

| Bit    | Bit 7    | Bit 6 | Bit 5 | Bit 4 | Bit 3      | Bit 2 | Bit 1 | Bit 0 |
|--------|----------|-------|-------|-------|------------|-------|-------|-------|
| Status | -        | -     | -     | -     | R/W        | R/W   | R/W   | R/W   |
| Name   | Reserved |       |       |       | EN_AD[3:0] |       |       |       |

| Bit Number | Bit Mnemonic | Description                                                                                                                                                                                                                          |
|------------|--------------|--------------------------------------------------------------------------------------------------------------------------------------------------------------------------------------------------------------------------------------|
| 7-4        | Reserved     | -                                                                                                                                                                                                                                    |
| 3-0        | EN_AD[3:0]   | Analog/Digital Channel Selection<br>0000: Select Channel CH0<br>0001: Select Channel CH1<br>0010: Select Channel CH2<br>0011: Select Channel CH3<br>0100: Select Channel CH4<br>0101: Select Channel CH5<br>0110: Select Channel CH6 |

| Bit Number | Bit Mnemonic | Description                                                                                                                                                                                                                                                    |
|------------|--------------|----------------------------------------------------------------------------------------------------------------------------------------------------------------------------------------------------------------------------------------------------------------|
|            |              | 0111: Select Channel CH7<br>1000: Select Channel CH8<br>1001: Select Channel CH9<br>1010: Select Channel CH10<br>1011: Select Channel CH11<br>1100: Select Channel CH12<br>1101: Select Channel CH13<br>1110: Select Channel CH14<br>1111: Select Channel CH15 |

∴ unimplemented.

**ADC Voltage Compare Data High Bytes Register ADC\_CMP\_V[9:2] (XFR: 0xD4)**
**Reset Value: 80h**

| Bit    | Bit 7          | Bit 6 | Bit 5 | Bit 4 | Bit 3 | Bit 2 | Bit 1 | Bit 0 |
|--------|----------------|-------|-------|-------|-------|-------|-------|-------|
| Status | R/W            | R/W   | R/W   | R/W   | R/W   | R/W   | R/W   | R/W   |
| Name   | ADC_CMP_V[9:2] |       |       |       |       |       |       |       |

| Bit Number | Bit Mnemonic   | Description                                                                              |
|------------|----------------|------------------------------------------------------------------------------------------|
| 7-0        | ADC_CMP_V[9:2] | ADC_CMP_V[9:2] Compare Voltage Setting, paired with ADC_CMP_V[1:0] to form a 10-bit data |

**ADC Voltage Compare Data Low Bytes Register ADC\_CMP\_V[1:0] (XFR: 0xD5)**
**Reset Value: 00h**

| Bit    | Bit 7    | Bit 6 | Bit 5 | Bit 4 | Bit 3 | Bit 2 | Bit 1          | Bit 0 |
|--------|----------|-------|-------|-------|-------|-------|----------------|-------|
| Status | -        | -     | -     | -     | -     | -     | R/W            | R/W   |
| Name   | Reserved |       |       |       |       |       | ADC_CMP_V[1:0] |       |

| Bit Number | Bit Mnemonic   | Description                                                                              |
|------------|----------------|------------------------------------------------------------------------------------------|
| 7-2        | Reserved       | -                                                                                        |
| 1-0        | ADC_CMP_V[1:0] | ADC_CMP_V[1:0] Compare Voltage Setting, paired with ADC_CMP_V[9:2] to form a 10-bit data |

∴ unimplemented.

**ADC Converted Data High Bytes Register AD\_DATA[9:2] (XFR: 0xD6)**
**Reset Value: 00h**

| Bit    | Bit 7        | Bit 6 | Bit 5 | Bit 4 | Bit 3 | Bit 2 | Bit 1 | Bit 0 |
|--------|--------------|-------|-------|-------|-------|-------|-------|-------|
| Status | R            | R     | R     | R     | R     | R     | R     | R     |
| Name   | AD_DATA[9:2] |       |       |       |       |       |       |       |

| Bit Number | Bit Mnemonic | Description                                                                         |
|------------|--------------|-------------------------------------------------------------------------------------|
| 7-0        | AD_DATA[9:2] | AD_DATA[9:2] converted data setting, paired with AD_DATA[1:0] to form a 10-bit data |

∴ unimplemented.

**ADC Converted Data Low Bytes Register AD\_DATA[1:0] (XFR: 0xD7)**

**Reset Value: 00h**

|        |          |       |       |       |       |       |              |       |
|--------|----------|-------|-------|-------|-------|-------|--------------|-------|
| Bit    | Bit 7    | Bit 6 | Bit 5 | Bit 4 | Bit 3 | Bit 2 | Bit 1        | Bit 0 |
| Status | -        | -     | -     | -     | -     | -     | R            | R     |
| Name   | Reserved |       |       |       |       |       | AD_DATA[1:0] |       |

| Bit Number | Bit Mnemonic | Description                                                                         |
|------------|--------------|-------------------------------------------------------------------------------------|
| 7-2        | Reserved     | -                                                                                   |
| 1-0        | AD_DATA[1:0] | AD_DATA[1:0] converted data setting, paired with AD_DATA[9:2] to form a 10-bit data |

**:- unimplemented.**



The setting of Enabling Analog/Digital Converter converted Data procedure:

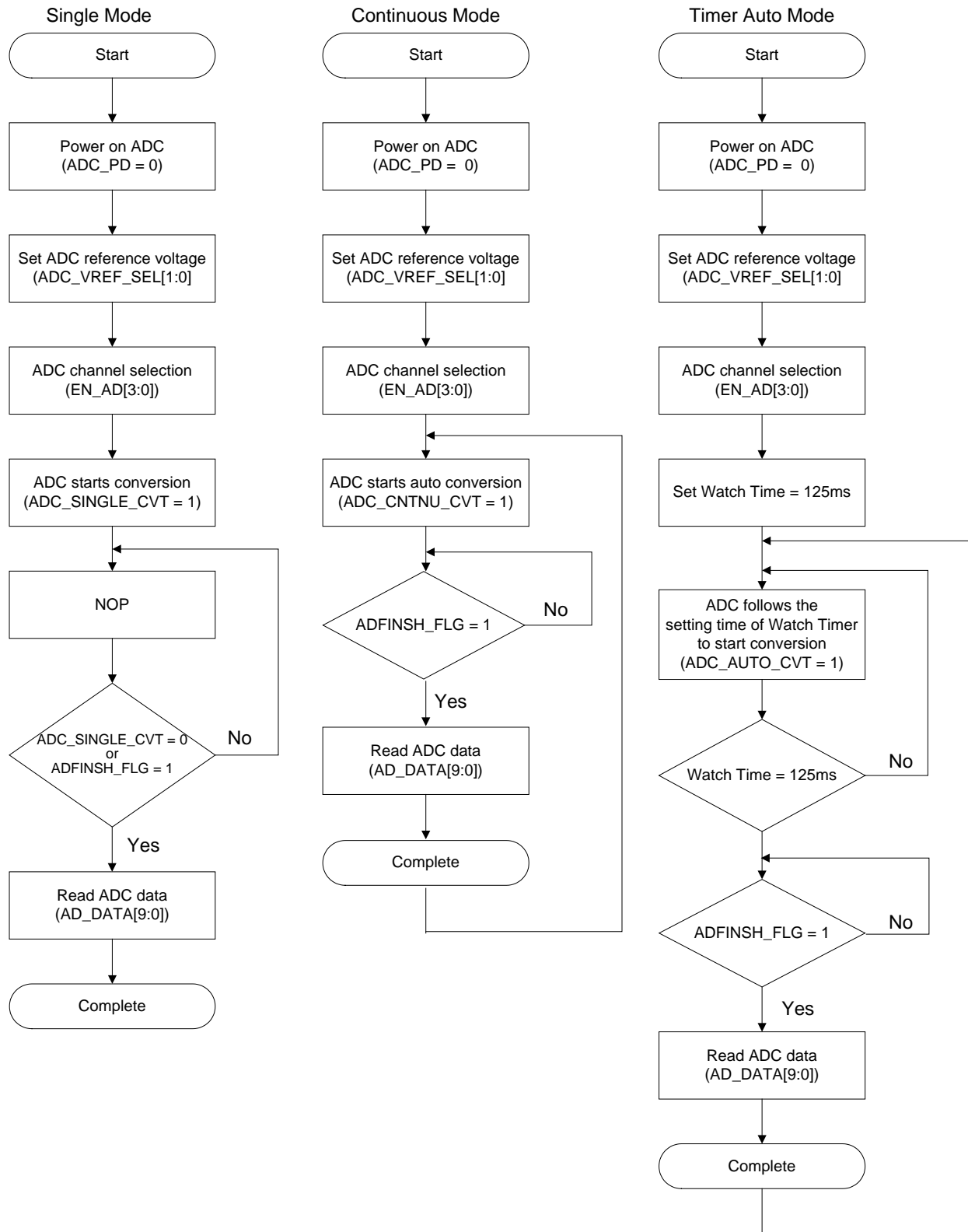

### 6.13 Low Voltage Reset (LVR)

WT51F108S/104S has a built-in Low Voltage Reset circuitry which can detect the supply voltage falls below the minimum specified operating voltage then generates a Reset, and it stops when the supply voltage is higher than the detection voltage  $V_{LVR}$ .

- The Enable and Disable function of Low Voltage Reset are controlled by the software
- Low Voltage Reset level is about  $1.50V \pm 10\%$ . Please refer to section 7.8 “Electrical Characteristics” for more details.

**Low Voltage Reset Control Register LVD\_CTL (XFR: 0x0C)**

**Reset Value: A6h**

| Bit    | Bit 7    | Bit 6 | Bit 5 | Bit 4 | Bit 3 | Bit 2 | Bit 1 | Bit 0  |
|--------|----------|-------|-------|-------|-------|-------|-------|--------|
| Status | -        | -     | -     | -     | -     | -     | -     | R/W    |
| Name   | Reserved |       |       |       |       |       |       | LVR_PD |

| Bit Number | Bit Mnemonic | Description                                                        |
|------------|--------------|--------------------------------------------------------------------|
| 7-1        | Reserved     | Must equal to “1100100”, otherwise LVR_PD cannot be written into   |
| 0          | LVR_PD       | 1: Power down “Low Voltage Reset”<br>0: Enable “Low Voltage Reset” |

## 6.14 Low Voltage Detection (LVD)

WT51F108S/104S has a built-in Low Voltage Detection circuitry which can detect the supply voltage falls below the minimum specified operating voltage then generates an Interrupt.

- The Enable and Disable function of Low Voltage Detection are controlled by the software
- Low Voltage Detection level provides 8-level of voltage for selection: 2.00V, 2.25V, 2.50V, 2.75V, 3.00V, 3.25V, 3.50V or 3.75V

### Low Voltage Detection Control Register LVD\_CTL (XFR: 0x02)

Reset Value: A6h

| Bit    | Bit 7  | Bit 6   | Bit 5        | Bit 4 | Bit 3 | Bit 2      | Bit 1            | Bit 0 |
|--------|--------|---------|--------------|-------|-------|------------|------------------|-------|
| Status | R/W    | R       | R/W          | R/W   | R/W   | R/W        | R/W              | R/W   |
| Name   | LVD_PD | LVD_CMP | LVD_LVL[2:0] |       |       | LVD_RST_PD | LVD_RST_LVL[1:0] |       |

| Bit Number | Bit Mnemonic | Description                                                                                                                                                               |
|------------|--------------|---------------------------------------------------------------------------------------------------------------------------------------------------------------------------|
| 7          | LVD_PD       | 1: Power down Low Voltage Detection<br>0: Turn on Low Voltage Detection                                                                                                   |
| 6          | LVD_CMP      | Low Voltage Detection Compared Result<br>1: Power Voltage < Setting Low Voltage Detection Voltage Range<br>0: Power Voltage > Setting Low Voltage Detection Voltage Range |
| 5-3        | LVD_LVL[2:0] | Low Voltage Detection Range:<br>000: 2.00V<br>001: 2.25V<br>010: 2.50V<br>011: 2.75V<br>100: 3.00V<br>101: 3.25V<br>110: 3.50V<br>111: 3.75V                              |

**Note:** The voltage range of Low Voltage Detection has great tolerance. Please refer to section 7.8 “Electrical Characteristics” for more details.

### 6.15 Low Voltage Detection Reset (LVDR)

WT51F108S/104S has a built-in Low Voltage Detection circuitry which can detect the supply voltage falls below the minimum specified operating voltage then generates a Reset.

- The Enable and Disable function of Low Voltage Detection Reset are controlled by the software
- Low Voltage Detection level provides 4-level of voltage for selection: 2.00V, 2.50V, 3.00V or 3.50V

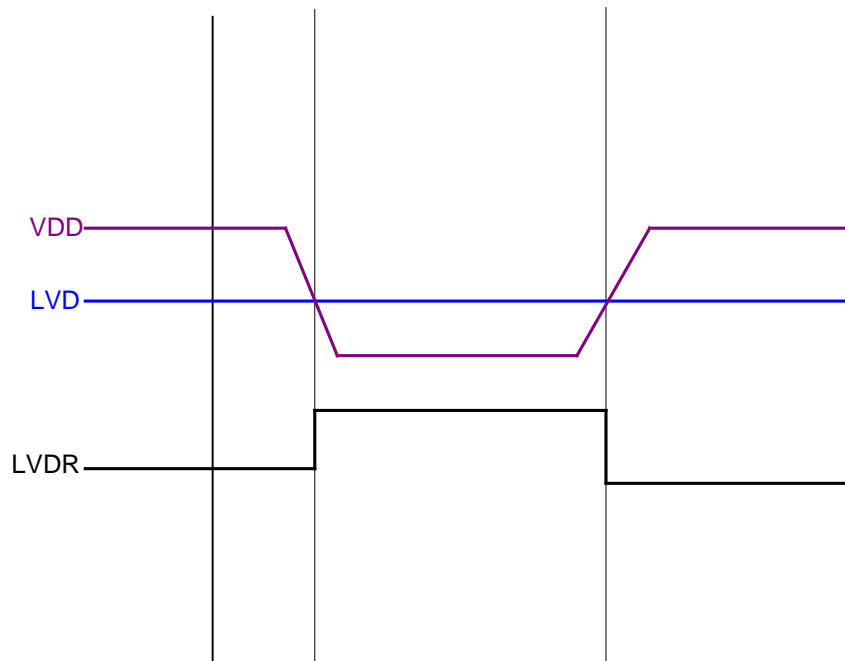

**Low Voltage Detection Control Register LVD\_CTL (XFR: 0x02)**

**Reset Value: A6h**

| Bit    | Bit 7  | Bit 6   | Bit 5        | Bit 4 | Bit 3 | Bit 2             | Bit 1                   | Bit 0      |
|--------|--------|---------|--------------|-------|-------|-------------------|-------------------------|------------|
| Status | R/W    | R       | R/W          | R/W   | R/W   | <b>R/W</b>        | <b>R/W</b>              | <b>R/W</b> |
| Name   | LVD_PD | LVD_CMP | LVD_LVL[2:0] |       |       | <b>LVD_RST_PD</b> | <b>LVD_RST_LVL[1:0]</b> |            |

| Bit Number | Bit Mnemonic     | Description                                                                                   |
|------------|------------------|-----------------------------------------------------------------------------------------------|
| 2          | LVD_RST_PD       | 1: Turn off Low Voltage Detection Reset power<br>0: Turn on Low Voltage Detection Reset power |
| 1-0        | LVD_RST_LVL[1:0] | Low Voltage Detection Reset Range:<br>00: 2.00V<br>01: 2.50V<br>10: 3.00V<br>11: 3.50V        |

**Note:** The voltage range of Low Voltage Detection has great tolerance. Please refer to section 7.8 “Electrical Characteristics” for more details.

**Reset Flag Register RESET\_FLG (XFR: 0x03)**
**Reset Value: 01h**

|        |             |                |             |             |          |             |             |             |
|--------|-------------|----------------|-------------|-------------|----------|-------------|-------------|-------------|
| Bit    | Bit 7       | Bit 6          | Bit 5       | Bit 4       | Bit 3    | Bit 2       | Bit 1       | Bit 0       |
| Status | W           | R              | R           | R           | R        | R           | R           | R           |
| Name   | CLR_RST_FLG | PC_OVL_RST_FLG | ISP_RST_FLG | WDT_RST_FLG | NRST_FLG | LVD_RST_FLG | LVR_RST_FLG | POR_RST_FLG |

| Bit Number | Bit Mnemonic   | Description                                         |
|------------|----------------|-----------------------------------------------------|
| 7          | CLR_RST_FLG    | 1: Clear all Reset Flag                             |
| 6          | PC_OVL_RST_FLG | 1: Reset source is from PC Counter Overflow         |
| 5          | ISP_RST_FLG    | 1: Reset source is from ISP                         |
| 4          | WDT_RST_FLG    | 1: Reset source is from Watchdog                    |
| 3          | NRST_FLG       | 1: Reset source is from External Reset pin          |
| 2          | LVD_RST_FLG    | 1: Reset source is from Low Voltage Detection Reset |
| 1          | LVR_RST_FLG    | 1: Reset source is from Low Voltage Reset           |
| 0          | POR_RST_FLG    | 1: Reset source is from External Power Reset        |

**Note:** For more details, refer to section 5.7 "Reset".

## 6.16 Emulated E<sup>2</sup>PROM

The WT51F108S/104S can use Flash PROM space to emulate E<sup>2</sup>PROM; 512-Bytes as a Bank.

**WT51F108S storage address locates from 0x1800 ~ 0x1DFF (1536 Bytes), 3 Banks in total.**

**WT51F104S storage address locates from 0x0C00 ~ 0x0DFF (512 Bytes), 1 Bank in total.**

### E<sup>2</sup>PROM Enable Register 1 EER\_EN1[3:0] (XFR: 0xE0)

Reset Value: 00h

| Bit    | Bit 7    | Bit 6 | Bit 5 | Bit 4 | Bit 3        | Bit 2 | Bit 1 | Bit 0 |
|--------|----------|-------|-------|-------|--------------|-------|-------|-------|
| Status | -        | -     | -     | -     | W            | W     | W     | W     |
| Name   | Reserved |       |       |       | EER_EN1[3:0] |       |       |       |

| Bit Number | Bit Mnemonic | Description                                                                                        |
|------------|--------------|----------------------------------------------------------------------------------------------------|
| 7-4        | Reserved     | -                                                                                                  |
| 3-0        | EER_EN1[3:0] | When EER_EN1[3:0] = '1010' and EER_EN2[3:0] = '0101', the E <sup>2</sup> PROM function is enabled. |

∴ unimplemented.

### E<sup>2</sup>PROM Enable Register 2 EER\_EN2[3:0] (XFR: 0xE1)

Reset Value: 00h

| Bit    | Bit 7    | Bit 6 | Bit 5 | Bit 4 | Bit 3        | Bit 2 | Bit 1 | Bit 0 |
|--------|----------|-------|-------|-------|--------------|-------|-------|-------|
| Status | -        | -     | -     | -     | W            | W     | W     | W     |
| Name   | Reserved |       |       |       | EER_EN2[3:0] |       |       |       |

| Bit Number | Bit Mnemonic | Description                                                                                        |
|------------|--------------|----------------------------------------------------------------------------------------------------|
| 7-4        | Reserved     | -                                                                                                  |
| 3-0        | EER_EN2[3:0] | When EER_EN2[3:0] = '0101' and EER_EN1[3:0] = '1010', the E <sup>2</sup> PROM function is enabled. |

∴ unimplemented.

### E<sup>2</sup>PROM Address Low Bytes Register EER\_ADDR[7:0] (XFR: 0xE2)

Reset Value: FFh

| Bit    | Bit 7         | Bit 6 | Bit 5 | Bit 4 | Bit 3 | Bit 2 | Bit 1 | Bit 0 |
|--------|---------------|-------|-------|-------|-------|-------|-------|-------|
| Status | R/W           | R/W   | R/W   | R/W   | R/W   | R/W   | R/W   | R/W   |
| Name   | EER_ADDR[7:0] |       |       |       |       |       |       |       |

| Bit Number | Bit Mnemonic  | Description                                                                        |
|------------|---------------|------------------------------------------------------------------------------------|
| 7-0        | EER_ADDR[7:0] | EER_ADDR[7:0] address setting, paired with EER_ADDR[10:8] to form a 11-bit address |

**E<sup>2</sup>PROM Address High Bytes Register EER\_ADDR[10:8] (XFR: 0xE3)**
**Reset Value: 07h**

| Bit    | Bit 7    | Bit 6 | Bit 5 | Bit 4 | Bit 3 | Bit 2          | Bit 1 | Bit 0 |
|--------|----------|-------|-------|-------|-------|----------------|-------|-------|
| Status | -        | -     | -     | -     | -     | R/W            | R/W   | R/W   |
| Name   | Reserved |       |       |       |       | EER_ADDR[10:8] |       |       |

| Bit Number | Bit Mnemonic   | Description                                                                        |
|------------|----------------|------------------------------------------------------------------------------------|
| 7-3        | Reserved       | -                                                                                  |
| 2-0        | EER_ADDR[10:8] | EER_ADDR[10:8] address setting, paired with EER_ADDR[7:0] to form a 11-bit address |

**E<sup>2</sup>PROM Control Register EER\_TCTL[3:0] (XFR: 0xE4)**
**Reset Value: 08h**

| Bit    | Bit 7    | Bit 6    | Bit 5     | Bit 4    | Bit 3         | Bit 2 | Bit 1 | Bit 0 |
|--------|----------|----------|-----------|----------|---------------|-------|-------|-------|
| Status | -        | -        | W         | W        | W             | W     | W     | W     |
| Name   | Reserved | Reserved | EER_ERASE | EER_PROG | EER_TCTL[3:0] |       |       |       |

| Bit Number | Bit Mnemonic  | Description                                                                         |
|------------|---------------|-------------------------------------------------------------------------------------|
| 7          | Reserved      | Must be set as "0"                                                                  |
| 6          | Reserved      | Must be set as "0"                                                                  |
| 5          | EER_ERASE     | 1: E <sup>2</sup> PROM proceeds ERASE (256 Bytes) /page<br>0: Did not proceed ERASE |
| 4          | EER_PROG      | 1: E <sup>2</sup> PROM proceeds PROGRAM (1 Byte)<br>0: Did not proceed PROGRAM      |
| 3-0        | EER_TCTL[3:0] | E <sup>2</sup> PROM ERASE/PROGRAM time setting (see "Notes")                        |

**E<sup>2</sup>PROM Break Register EER\_BRK (XFR: 0xE6)**
**Reset Value: 00h**

| Bit    | Bit 7            | Bit 6           | Bit 5              | Bit 4             | Bit 3    | Bit 2 | Bit 1 | Bit 0 |
|--------|------------------|-----------------|--------------------|-------------------|----------|-------|-------|-------|
| Status | R/W              | R/W             | R/W                | R/W               | -        | -     | -     | -     |
| Name   | EER_BRK_ERASE_EN | EER_BRK_PROG_EN | EER_BRK_ERASE_FLAG | EER_BRK_PROG_FLAG | Reserved |       |       |       |

| Bit Number | Bit Mnemonic       | Description                                                                 |
|------------|--------------------|-----------------------------------------------------------------------------|
| 7          | EER_BRK_ERASE_EN   | 1: Enable E <sup>2</sup> PROM erasing can be break by interrupt events      |
| 6          | EER_BRK_PROG_EN    | 1: Enable E <sup>2</sup> PROM programming can be break by interrupt events. |
| 5          | EER_BRK_ERASE_FLAG | 1: Erase operation Break Flag<br>CPU writes 0 to clear this flag            |
| 4          | EER_BRK_PROG_FLAG  | 1: Programming operation Break Flag<br>CPU writes 0 to clear this flag      |
| 3-0        | Reserved           | Must be set as 0                                                            |

**E<sup>2</sup>PROM Data Register EER\_DATA[7:0] (XFR: 0xE8)**
**Reset Value: 00h**

|        |               |       |       |       |       |       |       |       |
|--------|---------------|-------|-------|-------|-------|-------|-------|-------|
| Bit    | Bit 7         | Bit 6 | Bit 5 | Bit 4 | Bit 3 | Bit 2 | Bit 1 | Bit 0 |
| Status | W             | W     | W     | W     | W     | W     | W     | W     |
| Name   | EER_DATA[7:0] |       |       |       |       |       |       |       |

| Bit Number | Bit Mnemonic  | Description                       |
|------------|---------------|-----------------------------------|
| 7-0        | EER_DATA[7:0] | E <sup>2</sup> PROM Data Register |

**Notes:**

- MCU clock will be turned off in programming or erasing E<sup>2</sup>PROM, and thus all functions of 8052 are halt state. Please refer to 3.1 System Clock Tree for more details.  
Bit 7 and bit 6 of E<sup>2</sup>PROM Break Register (XFR: 0xE6) can be enabled, and then it is allowed to break writing or erasing and handle interrupt events immediately if any interrupt occurred during writing or erasing. After finishing the interrupt events, the unfinished writing or writing process can be continued by program.
- Recommended:  
Only if MCU\_CLK = 12 MHz, programming or erasing E<sup>2</sup>PROM is allowed, and EER\_TCTL[3:0] can be set as "1000". Thus, the programming time of 1 Byte = 80u sec ~ 85u sec. The erasing time of 1 Bank (256 Bytes) = 36m sec ~ 40m sec.
- LVR must be disabled prior to programming or erasing E<sup>2</sup>PROM; LVR can be enabled only after programming or erasing E<sup>2</sup>PROM is finished. Please refer to E<sup>2</sup>PROM Enable Flow chart for more details.

**WT51F108S E<sup>2</sup>PROM Clear Range and Address Setting (Cleared data 0xFF)**

| Flash address | EER_ADDR[10:8] | EER_ADDR[7:0] | Erase Range    | Remark        |
|---------------|----------------|---------------|----------------|---------------|
| 0x1800        | 000            | 0000 0000     | 0x1800~ 0x19FF | <b>BANK-0</b> |
| 0x1A00        | 010            | 0000 0000     | 0x1A00~ 0x1BFF | <b>BANK-1</b> |
| 0x1C00        | 100            | 0000 0000     | 0x1C00~ 0x1DFF | <b>BANK-2</b> |

**WT51F104S E<sup>2</sup>PROM Clear Range and Address Setting (Cleared data 0xFF)**

| Flash address | EER_ADDR[10:8] | EER_ADDR[7:0] | Erase Range     | Remark        |
|---------------|----------------|---------------|-----------------|---------------|
| 0x0C00        | 100            | 0000 0000     | 0x0C00 ~ 0x0DFF | <b>BANK-0</b> |



**E<sup>2</sup>PROM Enable Flow chart:**

**Programming function:**

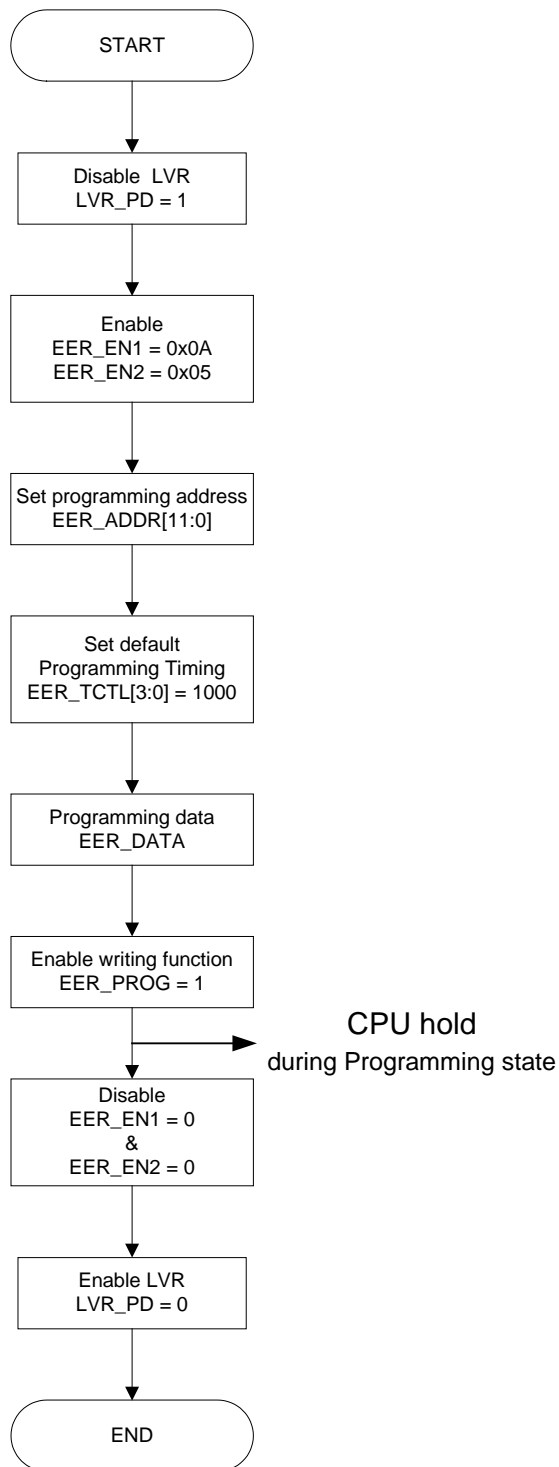

**Erasing function:**

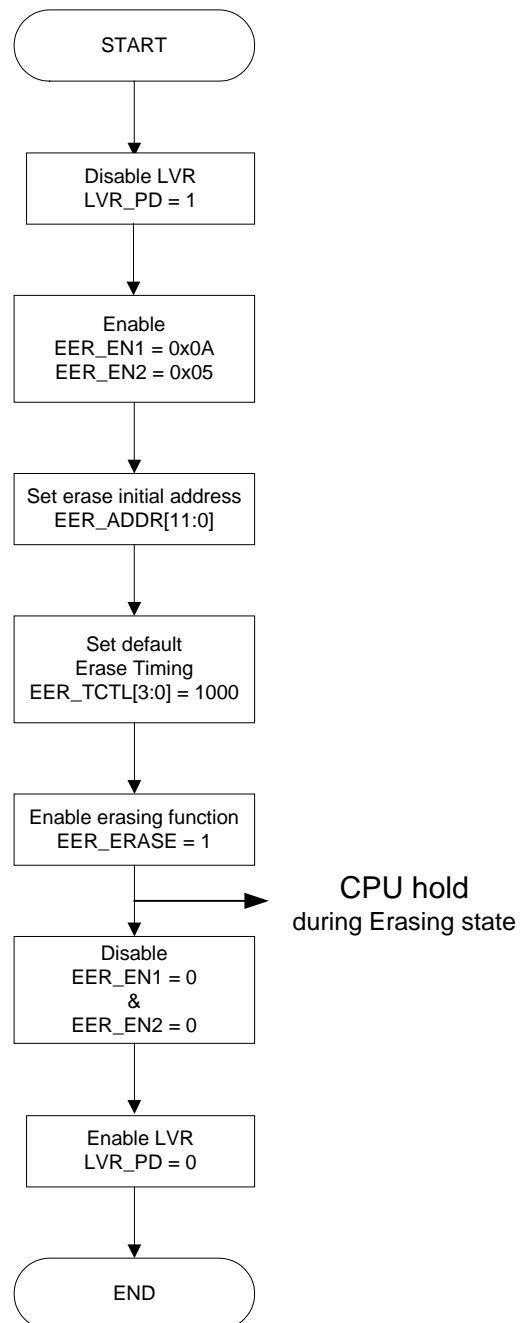

## 6.17 Code Option

Code Block located in the last eight bytes of Flash ROM for storing customer ID and IC configuration with address listed as the following table.

If this function is not enabled, please reserve the space of these eight bytes, and fill it with 0xFF.

If the function is enabled, WT51F108S/104S will auto reload the code option at each reset. Please refer to the Sequency Diagram as listed below.

| Address                                                      | Bit Number | Description                                                                                                                                                    |
|--------------------------------------------------------------|------------|----------------------------------------------------------------------------------------------------------------------------------------------------------------|
| 1FF8H/0FF8H                                                  | 7-0        | = AFH, enable Code Option function<br>= FFH, disable Code Option function<br>Default value 0xFF                                                                |
| 1FF9H/0FF9H                                                  | 7-0        | Customer ID 1, mapping to XFR: CSM_ID1 = 0x0D[7:0]<br>Default value 0xFF: code can be assigned by SWUT ISP software programming                                |
| 1FFAH/0FFAH                                                  | 7-0        | Customer ID 2, mapping to XFR: CSM_ID2 = 0x0E[7:0]<br>Default value 0xFF: code can be assigned by SWUT ISP software programming                                |
| 1FFBH/0FFBH                                                  | 7-0        | Customer ID 3, mapping to XFR: CSM_ID3 = 0x0F[7:0]<br>Default value 0xFF: code can be assigned by SWUT ISP software programming                                |
| 1FFCH/0FFCH                                                  | 7-0        | Flash memory content protection:<br>= 00H flash memory cannot be written into<br>= 10H flash memory cannot be read<br>Default value 0xFF: Flash can read/write |
| <b>General Purpose I/O Complex Function Options Setting:</b> |            |                                                                                                                                                                |
| 1FFDH/0FFDH                                                  | 7-5        | Reserved                                                                                                                                                       |
|                                                              | 4          | Mapping to XFR: GPA3_FUN_SLT = 26H[6:4]<br>1: Reset pin (NRST)<br>0: GPIO (default)                                                                            |
|                                                              | 3          | Mapping to XFR: GPA4_FUN_SLT = 25H[2:0]<br>1: Main External Crystal Oscillator pin (main crystal)<br>0: GPIO (default)                                         |
|                                                              | 2          | Mapping to XFR: LVD_RST_PD = 02H[2]<br>1: Disable Low Voltage Reset (default)<br>0: Enable Low Voltage Reset                                                   |
|                                                              | 1-0        | Mapping to XFR: LVD_RST_LVL = 02H[1:0], low voltage detection and reset level setting<br>00: 2.00V<br>01: 2.50V<br>10: 3.00V (default)<br>11: 3.50V            |

| Address                                                               | Bit Number | Description                                                                                                                                                                                                                                                                                            |
|-----------------------------------------------------------------------|------------|--------------------------------------------------------------------------------------------------------------------------------------------------------------------------------------------------------------------------------------------------------------------------------------------------------|
| <b>Oscillator Initialization and Driving Ability Options Setting:</b> |            |                                                                                                                                                                                                                                                                                                        |
| 1FFE <sub>H</sub> /0FFE <sub>H</sub>                                  | 7-5        | Reserved                                                                                                                                                                                                                                                                                               |
|                                                                       | 4-3        | Mapping to XFR: SOURCE_CLK_SLT[1:0] = 0x05 <sub>H</sub> [3:2]; initialization value of main oscillator<br>00: SOURCE clock = internal 12 MHz RC oscillator (default)<br>01: SOURCE clock = external 32 kHz ~ 24 MHz crystal oscillator<br>1X: SOURCE clock = internal 32 kHz RC oscillator             |
|                                                                       | 2-1        | Mapping to XFR: CRY_12M_DR[1:0] = 0x08 <sub>H</sub> [2:1]; oscillator driving ability selection<br>00: Select < 100 kHz crystal oscillator<br>01: Select 100 kHz ~ 1 MHz crystal oscillator<br>10: Select 1 MHz ~ 12 MHz crystal oscillator (default)<br>11: Select 12 MHz ~ 24 MHz crystal oscillator |
|                                                                       | 0          | Must be set as 0                                                                                                                                                                                                                                                                                       |
| <b>All Oscillator Power Switch Options Setting:</b>                   |            |                                                                                                                                                                                                                                                                                                        |
| 1FFF <sub>H</sub> /0FFF <sub>H</sub>                                  | 7-5        | Reserved                                                                                                                                                                                                                                                                                               |
|                                                                       | 4          | Mapping to XFR: IRC_12M_PD1 = 0x07 <sub>H</sub> [4]<br>1: Turn off partial power of internal 12 MHz RC oscillator<br>0: Turn on partial power of internal 12 MHz RC oscillator (default)                                                                                                               |
|                                                                       | 3          | Mapping to XFR: IRC_12M_PD2 = 0x07 <sub>H</sub> [3]<br>1: Turn off all power of internal 12 MHz RC oscillator<br>0: Turn on all power of internal 12 MHz RC oscillator (default)                                                                                                                       |
|                                                                       | 2          | Reserved                                                                                                                                                                                                                                                                                               |
|                                                                       | 1          | Mapping to XFR: CRY_12M_PD = 0x 07 <sub>H</sub> [1]<br>1: Turn off external 32 kHz ~ 24 MHz crystal oscillator (default)<br>0: Turn on external 32 kHz ~ 24 MHz crystal oscillator                                                                                                                     |
|                                                                       | 0          | Reserved                                                                                                                                                                                                                                                                                               |

**Note:** Code option setting would be overwritten by program setting, it is recommended to use the program to set the code option. Please refer to next page for code option setting examples and code example program.

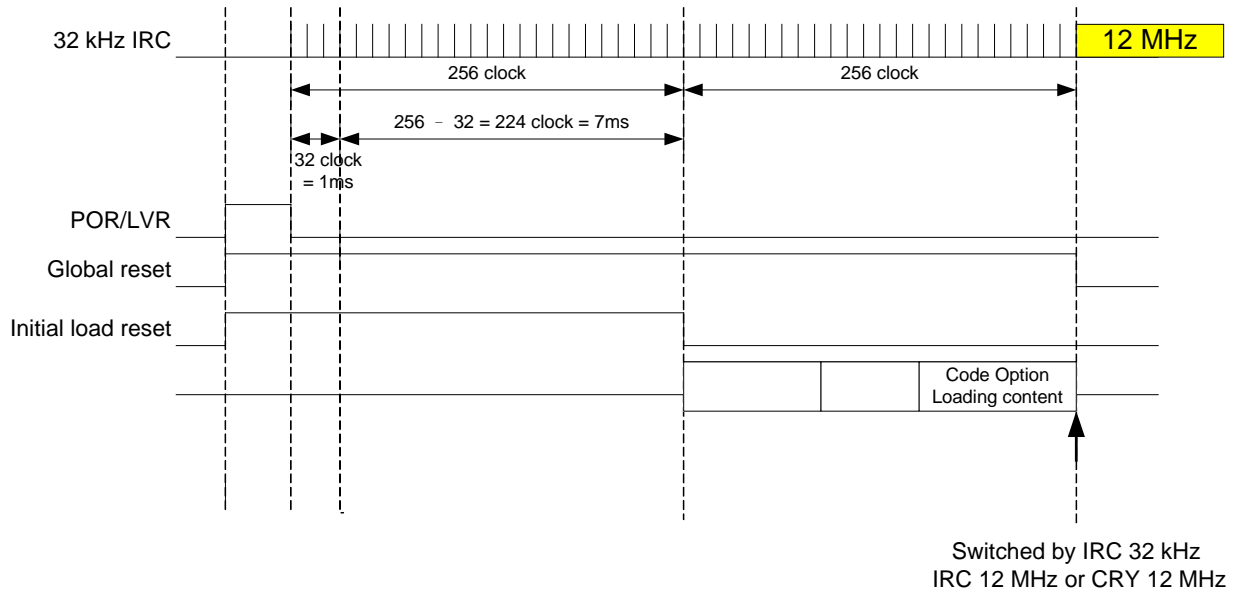

**WT51F108S/104S Code Option Examples:**

```

;-----
;For WT51F108S/104S Code Option Setting
;-----
#define OPTION_ON          1
#define OPTION_OFF        0
;;Default Code Option OFF
#define WT51F108S/104S_CODE_OPTION    OPTION_OFF

    #if(WT51F108S/104S_CODE_OPTION==OPTION_ON)
    ;;Load Code option switch
    CSEG    AT 0x1FF8    / 0x0FF8
    DB      10101111B    ;;0xAF: load code option

    ;;Customer ID 1
    CSEG    AT 0x1FF9 / 0x0FF9
    DB      11111111B
    ;;Customer ID 2
    CSEG    AT 0x1FFA / 0x0FFA
    DB      11111111B
    ;;Customer ID 3
    CSEG    AT 0x1FFB / 0x0FFB
    DB      11111111B

    ;;Flash Protect Read/Write
    CSEG    AT 0x1FFC / 0x0FFC
    ;;Flash memory content protection:
    ;;default 0xFF select no protection MCU can read/write
    ;;bit7-0 = 10H flash memory cannot be read
    ;;bit7-0 = 00H flash memory cannot be written into
    DB      11111111B

    ;;Crystal GPIO setting
    CSEG    AT 0x1FFD / 0x0FFD
    ;;bit7-5    NC default 0
    ;;bit4 Mapping to XFR: GPA4_FUN_SLT = 26H[5]
    ;;default 00 GPIOA4 set GPIO function
    ;;0: GPIO
    ;;1: Main crystal
    ;;bit3 Mapping to XFR: GPA3_FUN_SLT = 25H[1]
    ;;default 00 GPIOA3 set GPIO function
    ;;0: GPIO
    ;;1: NRST
    ;;bit2 Mapping to XFR: LVD_RST_PD 0x02H[2]
    ;;default 1 select disable
    ;;1: disable low voltage reset
    ;;0: enable low voltage reset
    ;;bit1-0 Mapping to XFR: LVD_RST_LVL 0x02H[1:0], low voltage detection and reset level setting
    ;;default 10 select 3.00V
    ;;00: 2.00V
    ;;01: 2.50V
    ;;10: 3.00V
    ;;11: 3.50V
    DB      00000110B

    ;;Source Clock and Crystal drive setting
    CSEG    AT 0x1FFE / 0x0FFE
    ;;bit7 NC default 0

```

```

;;bit6 NC default 0
;;bit5 NC default 0
;;bit4-3 Mapping to XFR: SOURCE_CLK_SLT[1:0] 0x05H[3:2]; initialization value of main oscillator
;;default 00
;;00: SOURCE clock = internal 12 MHz RC oscillator
;;01: SOURCE clock = external 32 kHz ~ 24 MHz crystal oscillator
;;1X: SOURCE clock = internal 32 kHz RC oscillator
;;bit2-1 Mapping to XFR: CRY_12M_DR[1:0] 0x08H[2:1]; oscillator driving ability selection
;;default 10
;;00: select 32768 kHz crystal oscillator
;;01: select 100 kHz ~ 1 MHz crystal oscillator
;;10: select 1 MHz ~ 12 MHz crystal oscillator
;;11: select 12 MHz ~ 24 MHz crystal oscillator
;;bit0 NC default 0
DB 00000100B

;;Crystal Power setting
CSEG AT 0x1FFF / 0x0FFF
;;bit7 NC default 0
;;bit6 NC default 0
;;bit5 NC default 0
;;bit4 Mapping to XFR: IRC_12M_PD1 0x07H[4] default turn on
;;1: turn off partial power of internal 12 MHz RC oscillator
;;0: turn on partial power of internal 12 MHz RC oscillator
;;bit3 Mapping to XFR: IRC_12M_PD2 0x07H[3] default turn on
;;1: turn off all power of internal 12 MHz RC oscillator
;;0: turn on all power of internal 12 MHz RC oscillator
;;bit2 Mapping to XFR: IRC_32K_PD 0x07H[2] default turn on
;;1: turn off the power of internal 32 kHz RC oscillator
;;0: turn of the power of internal 32 kHz RC oscillator
;;bit1 Mapping to XFR: CRY_12M_PD 0x07H[1] default turn off
;;1: Turn off external 32 kHz ~ 24 MHz crystal oscillator
;;0: Turn on external 32 kHz ~ 24 MHz crystal oscillator
;;bit0 NC default 0
DB 00000010B
#else
CSEG AT 0x1FF8 / 0x0FF8
DB 11111111B
CSEG AT 0x1FF9 / 0x0FF9
DB 11111111B
CSEG AT 0x1FFA / 0x0FFA
DB 11111111B
CSEG AT 0x1FFB / 0x0FFB
DB 11111111B
CSEG AT 0x1FFC / 0x0FFC
DB 11111111B
CSEG AT 0x1FFD / 0x0FFD
DB 11111111B
CSEG AT 0x1FFE / 0x0FFE
DB 11111111B
CSEG AT 0x1FFF / 0x0FFF
DB 11111111B
#endif

```

Customer ID 1~ 3 mapped to the Customer Code Registers, please refer to the following customer code registers.

**Customer Code Register 1 CSTM\_ID1 (XFR: 0x0D)**
**Reset Value: FFh**

|        |          |       |       |       |       |       |       |       |
|--------|----------|-------|-------|-------|-------|-------|-------|-------|
| Bit    | Bit 7    | Bit 6 | Bit 5 | Bit 4 | Bit 3 | Bit 2 | Bit 1 | Bit 0 |
| Status | R        | R     | R     | R     | R     | R     | R     | R     |
| Name   | CSTM_ID1 |       |       |       |       |       |       |       |

| Bit Number | Bit Mnemonic | Description                                                         |
|------------|--------------|---------------------------------------------------------------------|
| 7-0        | CSTM_ID1     | Customer code, paired with CSTM_ID2 and CSTM_ID3, 3 bytes in total. |

**Customer Code Register 2 CSTM\_ID2 (XFR: 0x0E)**
**Reset Value: FFh**

|        |          |       |       |       |       |       |       |       |
|--------|----------|-------|-------|-------|-------|-------|-------|-------|
| Bit    | Bit 7    | Bit 6 | Bit 5 | Bit 4 | Bit 3 | Bit 2 | Bit 1 | Bit 0 |
| Status | R        | R     | R     | R     | R     | R     | R     | R     |
| Name   | CSTM_ID2 |       |       |       |       |       |       |       |

| Bit Number | Bit Mnemonic | Description                                                         |
|------------|--------------|---------------------------------------------------------------------|
| 7-0        | CSTM_ID2     | Customer code, paired with CSTM_ID3 and CSTM_ID1, 3 bytes in total. |

**Customer Code Register 3 CSTM\_ID3 (XFR: 0x0F)**
**Reset Value: FFh**

|        |          |       |       |       |       |       |       |       |
|--------|----------|-------|-------|-------|-------|-------|-------|-------|
| Bit    | Bit 7    | Bit 6 | Bit 5 | Bit 4 | Bit 3 | Bit 2 | Bit 1 | Bit 0 |
| Status | R        | R     | R     | R     | R     | R     | R     | R     |
| Name   | CSTM_ID3 |       |       |       |       |       |       |       |

| Bit Number | Bit Mnemonic | Description                                                         |
|------------|--------------|---------------------------------------------------------------------|
| 7-0        | CSTM_ID3     | Customer code, paired with CSTM_ID1 and CSTM_ID2, 3 bytes in total. |

**Note:** WT51F108S/104S provides three bytes (24 bits) of code option, which can be set by customer to read data from program storage after reset.

The following registers are described in the previous section, and now are set for the Code Option registers mapped in the General-purpose I/O Complex Function options, including the Option settings of the crystal oscillator pins, Reset, and Low Voltage Detection Reset.

0x25, 0x26, 0x02 registers again described as below.

**General-purpose I/O Port A Complex Function Setting Register 1 GPIOA\_FUN1 (XFR: 0x25) Reset Value: 00h**

|        |          |                   |       |       |          |                   |       |       |
|--------|----------|-------------------|-------|-------|----------|-------------------|-------|-------|
| Bit    | Bit 7    | Bit 6             | Bit 5 | Bit 4 | Bit 3    | Bit 2             | Bit 1 | Bit 0 |
| Status | -        | R/W               | R/W   | R/W   | -        | R/W               | R/W   | R/W   |
| Name   | Reserved | GPA5_FUN_SLT[2:0] |       |       | Reserved | GPA4_FUN_SLT[2:0] |       |       |

| Bit Number | Bit Mnemonic      | Description                                                                                                                                                                                                                                                                                                                                                                |
|------------|-------------------|----------------------------------------------------------------------------------------------------------------------------------------------------------------------------------------------------------------------------------------------------------------------------------------------------------------------------------------------------------------------------|
| 7          | Reserved          | -                                                                                                                                                                                                                                                                                                                                                                          |
| 6-4        | GPA5_FUN_SLT[2:0] | Set GPIOA5DH complex function<br>000: GPIO/ETMID (default) (*Notes1)<br>001: ADC15 input<br>011: PWM1 output of Path B<br><b>101: P00 output/input (mapping to 8052 P0.0) (*Notes2)</b><br>Note: If GPIOA4 = OCSO, the complex function of GPIOA5 will be invalid.                                                                                                         |
| 3          | Reserved          | -                                                                                                                                                                                                                                                                                                                                                                          |
| 2-0        | GPA4_FUN_SLT[2:0] | Set GPIOA4DH complex function<br>000: GPIO/ETMIA (default) (*Notes1)<br>001: ADC14 input<br>010: OSCO (served as external crystal oscillator output pin, and was forced to set GPIOA5DH as external crystal oscillator input pin (OSCI) instead of GPIO function) (*Notes3)<br>011: PWM0 output of Path B<br><b>101: P01 output/input (mapping to 8052 P0.1) (*Notes2)</b> |

-: unimplemented.

**Notes 1:** While using the external input pins (ETMID & ETMIA) of the Enhanced Timer/Counter, please set GPIOA5/GPIOA4 as GPIO of input mode.

**Notes 2:** While using 8052 port (P0.x) or UART, please set the mapping GPIOx\_TYP as open drain, and add external pull-high resistor.

**Notes 3:** The setting of using External Crystal Oscillator as SOURCE clock:

1. Set GPIOA5 and GPIOA4 as Input port. (XFR 0x10 GPIOA\_OE[5:4])
2. GPIOA5 and GPIOA4 disable internal pull high resistor. If enable pull high resistor will result in oscillator outputs unstable frequency. (XFR 0x1C GPIOA\_PHN[5:4])
3. Set GPIOA4 as OSCO crystal oscillator pin. (XFR 0x25 GPA4\_FUN\_SLT[2:0])
4. Set the complex function of GPIOA5 as GPIO. (XFR 0x25 GPA5\_FUN\_SLT[2:0])
5. Set the driving ability of External Crystal Oscillator. (XFR 0x08 CRY\_12M\_DR[1:0])
6. Power on External Crystal Oscillator switch. (XFR 0x07 CRY\_12M\_PD)
7. Switch SOURCE clock to External Crystal Oscillator. (XFR 0x05 SOURCE\_CLK\_SLT[1:0])

**General-purpose I/O Port A Complex Function Setting Register 2 GPIOA\_FUN2 (XFR: 0x26)      Reset Value: 00h**

| Bit    | Bit 7    | Bit 6             | Bit 5 | Bit 4 | Bit 3    | Bit 2             | Bit 1 | Bit 0 |
|--------|----------|-------------------|-------|-------|----------|-------------------|-------|-------|
| Status | -        | R/W               | R/W   | R/W   | -        | R/W               | R/W   | R/W   |
| Name   | Reserved | GPA3_FUN_SLT[2:0] |       |       | Reserved | GPA2_FUN_SLT[2:0] |       |       |

| Bit Number | Bit Mnemonic      | Description                                                                                                |
|------------|-------------------|------------------------------------------------------------------------------------------------------------|
| 7          | Reserved          | -                                                                                                          |
| 6-4        | GPA3_FUN_SLT[2:0] | Set GPIA3 complex function<br>000: GPIO/ETMIB (default)<br>001: ADC13 input<br>010: Reset pin (NRST) input |



| Bit Number | Bit Mnemonic      | Description                                                                                                                       |
|------------|-------------------|-----------------------------------------------------------------------------------------------------------------------------------|
| 3          | Reserved          | -                                                                                                                                 |
| 2-0        | GPA2_FUN_SLT[2:0] | Set GPIOA2DH complex function<br>000: GPIO/IRQ2/EMTIC (default)<br>001: ADC2 input<br>011: PWM1 output of Path C<br>101: T0 input |

-: unimplemented.

**Low Voltage Detection Control Register LVD\_CTL (XFR: 0x02)**
**Reset Value: A6h**

| Bit    | Bit 7  | Bit 6   | Bit 5        | Bit 4 | Bit 3 | Bit 2      | Bit 1            | Bit 0 |
|--------|--------|---------|--------------|-------|-------|------------|------------------|-------|
| Status | R/W    | R       | R/W          | R/W   | R/W   | R/W        | R/W              | R/W   |
| Name   | LVD_PD | LVD_CMP | LVD_LVL[2:0] |       |       | LVD_RST_PD | LVD_RST_LVL[1:0] |       |

| Bit Number | Bit Mnemonic | Description                                                                                                                                                               |
|------------|--------------|---------------------------------------------------------------------------------------------------------------------------------------------------------------------------|
| 7          | LVD_PD       | 1: Power down Low Voltage Detection<br>0: Turn on Low Voltage Detection                                                                                                   |
| 6          | LVD_CMP      | Low Voltage Detection Compared Result<br>1: Power Voltage < Setting Low Voltage Detection Voltage Range<br>0: Power Voltage > Setting Low Voltage Detection Voltage Range |
| 5-3        | LVD_LVL[2:0] | Low Voltage Detection Range:<br>000: 2.00V<br>001: 2.25V<br>010: 2.50V<br>011: 2.75V<br>100: 3.00V<br>101: 3.25V<br>110: 3.50V<br>111: 3.75V                              |

The following registers is described in the previous section, and now is set for the Code Option registers mapped in the Initialized Oscillator & Driving Ability options, including the Option settings of the crystal oscillator source and Driving ability.

0x05, 0x08 Register again described as below.

**System Clock Source Control Register SOURCE\_CLK\_SLT (XFR: 0x05)**
**Reset Value: A0h**

| Bit    | Bit 7    | Bit 6 | Bit 5 | Bit 4 | Bit 3               | Bit 2 | Bit 1            | Bit 0 |
|--------|----------|-------|-------|-------|---------------------|-------|------------------|-------|
| Status | -        | -     | -     | -     | R/W                 | R/W   | R/W              | R/W   |
| Name   | Reserved |       |       |       | SOURCE_CLK_SLT[1:0] |       | MCU_CLK_SLT[1:0] |       |

| Bit Number | Bit Mnemonic        | Description                                                                                                                  |
|------------|---------------------|------------------------------------------------------------------------------------------------------------------------------|
| 7-4        | Reserved            | Must be equal to "1010", otherwise bit [3:0] cannot be written into.                                                         |
| 3-2        | SOURCE_CLK_SLT[1:0] | Select SOURCE clock sources<br>00: Internal 12/24 MHz RC oscillator (default)<br>01: External DC ~ 24 MHz crystal oscillator |

| Bit Number | Bit Mnemonic     | Description                                                                                                                                                                                                           |
|------------|------------------|-----------------------------------------------------------------------------------------------------------------------------------------------------------------------------------------------------------------------|
|            |                  | 10: Internal 32 kHz RC oscillator<br>Default value can be selected by section 6.17 Code Option Select<br><b>Note: Prior to switching SOURCE_CLK_SLT[1:0], please set the corresponding power of IRC_12M_PD as ON.</b> |
| 1-0        | MCU_CLK_SLT[1:0] | MCU clock setting<br>00: MCU clock = SOURCE clock (default)<br>01: MCU clock = SOURCE clock /2<br>10: MCU clock = SOURCE clock /4<br>11: MCU clock = SOURCE clock /12                                                 |

-: unimplemented.

Notes:

- When SOURCE clock selects internal 32 kHz RC oscillator and the system clock source of the Watch Timer selects External 32.768 kHz crystal oscillator, Interrupt sources cannot be captured in time due to Internal 32 kHz RC oscillator with huge tolerance and the execute speed is slower than the Interrupt generated by Watch Timer. In this mode, it requires having the External Clock Source Prescaler Control Register 1 and External Clock Source Prescaler Control Register 2 setting divided by 2, and the Watch Timer clock source divided by 2 equals to 16.384 kHz. In the meantime, the time period selected by the Watch Timer will be extended twice to capture completely without missing.

Setting External Clock Source/ 2 procedures:

- Setting Prescaler Data:  $CRY\_DIV[9:0] = 1$ , and  $32.768\text{ kHz}/(CRY\_DIV[9:0]+1) = 32.768\text{ kHz}/2 = 16.384\text{ kHz}$
- Enable external crystal oscillator clock source prescaler:  $EN\_CRY\_DIV = 1$

### Oscillator Driver Control Register CRY\_12M\_DR[1:0] (XFR: 0x08)

Reset Value: 54h

| Bit    | Bit 7    | Bit 6 | Bit 5 | Bit 4 | Bit 3      | Bit 2           | Bit 1    | Bit 0 |
|--------|----------|-------|-------|-------|------------|-----------------|----------|-------|
| Status | -        | -     | -     | -     | -          | R/W             | R/W      | -     |
| Name   | Reserved |       |       |       | CRY_DR_ENH | CRY_12M_DR[1:0] | Reserved |       |

| Bit Number | Bit Mnemonic    | Description                                                                                                                                                                                                                                                                                                                                                                                                                                                                                                                                                                                                                                                                                                                                          |
|------------|-----------------|------------------------------------------------------------------------------------------------------------------------------------------------------------------------------------------------------------------------------------------------------------------------------------------------------------------------------------------------------------------------------------------------------------------------------------------------------------------------------------------------------------------------------------------------------------------------------------------------------------------------------------------------------------------------------------------------------------------------------------------------------|
| 7-4        | Reserved        | Must be equal to "0101", otherwise, Bit[3:0] cannot be written into                                                                                                                                                                                                                                                                                                                                                                                                                                                                                                                                                                                                                                                                                  |
| 3          | CRY_DR_ENH      | 1: Enhanced the driving ability of External Crystal Oscillator                                                                                                                                                                                                                                                                                                                                                                                                                                                                                                                                                                                                                                                                                       |
| 2-1        | CRY_12M_DR[1:0] | If CRY_DR_ENH =0; External oscillator driving ability setting<br>00: Crystal oscillator with frequency of 32 kHz, power consumption < 3uA<br>01: Crystal oscillator with frequency of 100 kHz ~ 1 MHz, power consumption < 60uA<br>10: Crystal oscillator with frequency of 1 MHz ~ 12 MHz, power consumption < 300uA (default)<br>11: Crystal oscillator with frequency of 12 MHz ~ 24 MHz, power consumption < 600uA<br><br>If CRY_DR_ENH =1; External oscillator driving ability setting<br>00: Crystal oscillator with frequency of 32 kHz, power consumption < 10uA<br>01: Crystal oscillator with frequency of 100 kHz ~ 1 MHz, power consumption < 80uA<br>10: Crystal oscillator with frequency of 1 MHz ~ 12 MHz, power consumption < 400uA |

Copyright© 2016 Weltrend Semiconductor, Inc. All Rights Reserved.

Weltrend reserves right to modify all information contained in this document without notice.

| Bit Number | Bit Mnemonic | Description                                                                                                                                                 |
|------------|--------------|-------------------------------------------------------------------------------------------------------------------------------------------------------------|
|            |              | 11: Crystal oscillator with frequency of 12 MHz ~ 24 MHz, power consumption < 800uA<br><br>Default value can be selected by section 6.17 Code Option Select |
| 0          | Reserved     | -                                                                                                                                                           |

∴ unimplemented.

**Note:** Due to WT51F108S/104S only supports one set of external oscillator input, it requires setting the driving ability of oscillator according to the frequency of external oscillator input. Please see the table below.

| External Crystal Oscillator | CRY_12M_DR[1:0] |
|-----------------------------|-----------------|
| 24 MHz ~ 12 MHz             | 11              |
| 12 MHz ~ 1 MHz              | 10              |
| 1 MHz ~ 100 kHz             | 01              |
| 32.768 kHz                  | 00              |

Below Code Option setting illustrates all Oscillator Power Switch Option setting, and it is recommended to set it according to its Reset value. If you want to use an external oscillator, please wait till MCU executes procedures.

**Clock Source Control Register IRC\_12M\_PD (XFR: 0x07)**
**Reset Value: A2h**

| Bit    | Bit 7    | Bit 6 | Bit 5 | Bit 4       | Bit 3       | Bit 2      | Bit 1      | Bit 0    |
|--------|----------|-------|-------|-------------|-------------|------------|------------|----------|
| Status | -        | -     | -     | R/W         | R/W         | R/W        | R/W        | -        |
| Name   | Reserved |       |       | IRC_12M_PD1 | IRC_12M_PD2 | IRC_32K_PD | CRY_12M_PD | Reserved |

| Bit Number | Bit Mnemonic | Description                                                                                                        |
|------------|--------------|--------------------------------------------------------------------------------------------------------------------|
| 7-5        | -            | Must be equal to "101", otherwise bit[4:0] cannot be written into                                                  |
| 4          | IRC_12M_PD1  | 1: Partial internal 12/24 MHz RC oscillator power is turned off (bias ON) (default value is not off)<br>0: Not off |
| 3          | IRC_12M_PD2  | 1: All internal 12/24 MHz RC oscillator power are turned off (bias off) (default value is not off)<br>0: Not off   |
| 2          | IRC_32K_PD   | 1: Internal 32 kHz RC oscillator power is turned off (default value is not off)<br>0: Not off                      |
| 1          | CRY_12M_PD   | 1: External 12/24 MHz ~ 32 kHz crystal oscillator power is turned off (default value is off)<br>0: Not off         |
| 0          | Reserved     | -                                                                                                                  |

∴ unimplemented.

**Note:** In Green mode, IRC\_12M\_PD (XFR\_0x07) must be set by the customer to turn off unnecessary clock source for saving power.

## 6.18 Read Out Protection

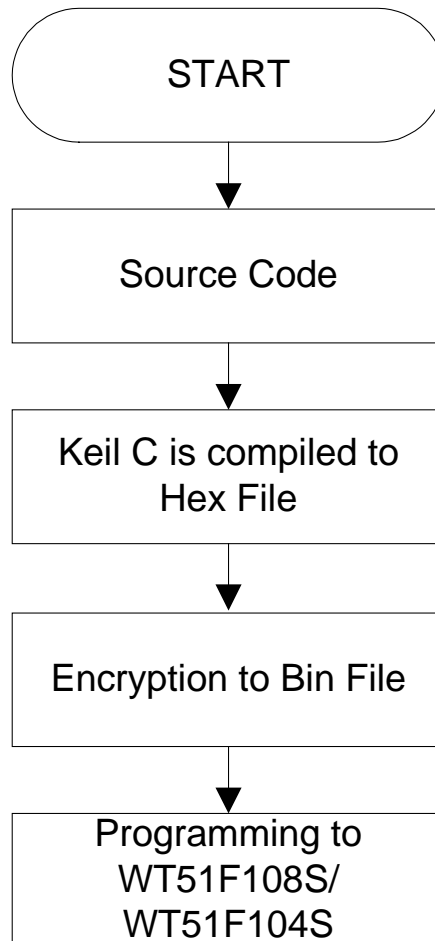

## 6.19 Internal Voltage Reference Source (BandGap)

Internal Voltage Reference Source (Bandgap) has been calibrated out of the factory with 1% precision. It supports 2.44V/1.23V BandGap Voltage selection, and can be set by BGP\_VOL\_SLT(XFR\_0x01\_bit3). Please pay attention to the power voltage (VDD) range in operation.

For more detailed Electrical Characteristics, please refer to section 7.7.

Regarding Internal Voltage Reference Bandgap selection 1.23V/2.44V, please refer to the information below.

### System Control Register SYS\_CTL (XFR: 0x01)

Reset Value: 80h

| Bit    | Bit 7   | Bit 6           | Bit 5           | Bit 4        | Bit 3              | Bit 2         | Bit 1       | Bit 0        |
|--------|---------|-----------------|-----------------|--------------|--------------------|---------------|-------------|--------------|
| Status | R/W     | R/W             | R/W             | R/W          | R/W                | R/W           | R/W         | R/W          |
| Name   | RST_NDF | LVD_RST_LVL_ADJ | EN_ADDR_OVL_RST | CRY_CLK_DIV2 | <b>BGP_VOL_SLT</b> | HFIRC_CLK_SLT | WDT_CLK_SLT | WTMR_CLK_SLT |

| Bit Number | Bit Mnemonic       | Description                                                                                                                |
|------------|--------------------|----------------------------------------------------------------------------------------------------------------------------|
| 7          | RST_NDF            | 1: NRST pin without digital filter function<br>0: NRST pin with digital filter function (4 clocks)                         |
| 6          | LVD_RST_LVL_ADJ    | 1: +0.25V<br>0: +0V                                                                                                        |
| 5          | ED_ADDR_OVL_RST    | 1: Enable "PC Counter Overflow Reset"<br>0: Disable "PC Counter Overflow Reset"                                            |
| 4          | CRY_CLK_DIV2       | 1: Enable "External Crystal Oscillator Prescaler"/2<br>0: Disable "External Crystal Oscillator Prescaler"                  |
| 3          | <b>BGP_VOL_SLT</b> | <b>1: BandGap = 2.44V</b><br>0: BandGap = 1.23V                                                                            |
| 2          | HFIRC_CLK_SLT      | 1: Internal IRC oscillator = 24 MHz<br>0: Internal IRC oscillator = 12 MHz                                                 |
| 1          | WDT_CLK_SLT        | 1: Watchdog Timer uses external 24 MHz ~ 32 kHz crystal oscillator<br>0: Watchdog Timer uses internal 32 kHz RC oscillator |
| 0          | WTMR_CLK_SLT       | 1: Watch Timer uses external 24 MHz ~ 32 kHz crystal oscillator<br>0: Watch Timer uses internal 32 kHz RC oscillator       |

-: unimplemented.

## 7. Electrical Characteristics

### 7.1 Absolute Maximum Ratings

| Parameter                        | Symbol        | Condition | Range                  | Units |
|----------------------------------|---------------|-----------|------------------------|-------|
| D.C. Supply Voltage              | $V_{DD}$      |           | -0.3 ~ 6.0             | V     |
| Input Voltage                    | $V_I$         |           | -0.3 to $V_{DD} + 0.3$ | V     |
| Output Voltage                   | $V_O$         |           | -0.3 to $V_{DD} + 0.3$ | V     |
| Total current source by all GPIO | $\sum I_{OH}$ |           | 90@-40°C ~ +105°C      | mA    |
| Total current sink by all GPIO   | $\sum I_{OL}$ |           | 90@-40°C ~ +105°C      | mA    |
| Ambient Temperature              | $T_A$         |           | -40 ~ 105              | °C    |
| Storage Temperature              | $T_{STG}$     |           | -60 ~ 125              | °C    |

**Note:** Stresses above those listed may cause permanent damage to the devices.

### 7.2 Recommended Operating Parameters

| Parameter                       | Symbol      | Condition                                    | Specification |        |     | Units       |
|---------------------------------|-------------|----------------------------------------------|---------------|--------|-----|-------------|
|                                 |             |                                              | Min           | Typ.   | Max |             |
| Power Voltage                   | $V_{DD}$    | $F_{main} = 12/24$ MHz                       | 1.8           |        | 5.5 | V           |
| Main Frequency                  | $F_{main}$  | $V_{DD} = 1.8V \sim 5.5V$                    |               | 12/24  |     | MHz         |
| Sub Frequency                   | $F_{sub}$   | $V_{DD} = V_{DD}$                            |               | 32.768 |     | kHz         |
| Operating Temperature           | $T_{OPR}$   |                                              | -40           |        | 105 | °C          |
| POR (Power on Reset) Level      | $V_{POR}$   | At $V_{DDTR} = 30ms$ ,<br>$T_A = 25^\circ C$ |               | 1.15   |     | V           |
| VDD Rising Rate <sup>(*)</sup>  | $V_{DDTRA}$ |                                              | 50            |        |     | $\mu S / V$ |
| VDD Falling Rate <sup>(*)</sup> | $V_{DDTFA}$ |                                              | 150           |        |     | $\mu S / V$ |

**(\*):** These parameters are presented for design guidance only and not tested or guaranteed.

#### Power On Reset (POR) Timing

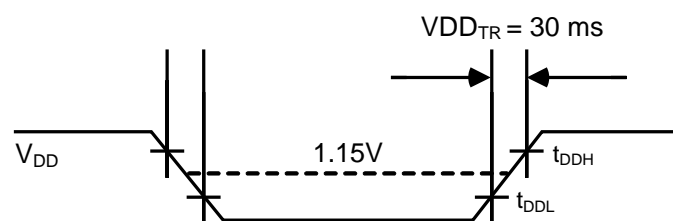

**7.3 DC Electrical Characteristics ( $V_{DD} = 1.8V \sim 5V, -40^{\circ}C \sim +105^{\circ}C$ )**

| Parameter                             | Symbol       | Condition                                                                                             | Specification  |            |                | Units     |
|---------------------------------------|--------------|-------------------------------------------------------------------------------------------------------|----------------|------------|----------------|-----------|
|                                       |              |                                                                                                       | Min            | Typ.       | Max            |           |
| Schmitt Trigger from Low to High      | $V_{T+}$     | $V_{DD} = 1.8V \sim 5.5V$                                                                             | $0.6 V_{DD}$   |            | $V_{DD} + 0.3$ | V         |
| Schmitt Trigger from High to Low      | $V_{T-}$     | $V_{DD} = 1.8V \sim 5.5V$                                                                             |                |            | $0.2 V_{DD}$   | V         |
| Output High Voltage (Note)            | $V_{OH4}$    | $I_{OH} = 4\text{ mA}$<br>at $V_{DD} = 5V$<br>GPIOB1 ~ GPIOB7,<br>GPIOC0 ~ GPIOC7,<br>GPIOD0 ~ GPIOD5 | $V_{DD} - 0.4$ |            |                | V         |
|                                       | $V_{OH8}$    | $I_{OH} = 8\text{ mA}$<br>at $V_{DD} = 5V$<br>GOIOA0 ~ GPIOA2,<br>GPIOA4 ~ GPIOA7                     | $V_{DD} - 0.4$ |            |                |           |
| Output Low Voltage (Note)             | $V_{OL4}$    | $I_{OL} = 4\text{ mA}$<br>at $V_{DD} = 5V$<br>GPIOB1 ~ GPIOB7,<br>GPIOC0 ~ GPIOC7,<br>GPIOD0 ~ GPIOD5 |                |            | $V_{SS} + 0.4$ | V         |
|                                       | $V_{OL8}$    | $I_{OL} = 8\text{ mA}$<br>at $V_{DD} = 5V$<br>GOIOA0 ~ GPIOA2,<br>GPIOA4 ~ GPIOA7                     |                |            | $V_{SS} + 0.4$ |           |
| Input Leakage Current <sup>(*)</sup>  | $I_{OZ}$     | $V_O = 0V$ or $V_{DDV}$                                                                               |                | $\pm 0.01$ | $\pm 1$        | $\mu A$   |
| Pull-up Resistor                      | $R_{PH}$     | $V_{DD} = 5V, V_{PIN} = 0V$                                                                           |                | 33         |                | $K\Omega$ |
| Normal mode at 24 MHz Working Current | $I_{VDD24M}$ | No load on output ( $V_{DD} = 5V$ , IRC24M on), peripheral off                                        |                | 2.9        |                | mA        |
| Normal mode at 12 MHz Working Current | $I_{VDD12M}$ | No load on output ( $V_{DD} = 5V$ , IRC12M on), peripheral off                                        |                | 1.5        |                | mA        |
| Normal mode at 6 MHz Working Current  | $I_{VDD6M}$  | No load on output ( $V_{DD} = 5V$ , IRC12M on), peripheral off                                        |                | 1          |                | mA        |
| Normal mode at 3 MHz Working Current  | $I_{VDD3M}$  | No load on output ( $V_{DD} = 5V$ , IRC12M on), peripheral off                                        |                | 0.75       |                | mA        |
| Normal mode at 1 MHz Working Current  | $I_{VDD1M}$  | No load on output ( $V_{DD} = 5V$ , IRC12M on), peripheral off                                        |                | 0.55       |                | mA        |
| Idle mode Working Current             | $I_{VDDS1}$  | No load on output ( $V_{DD} = 5V$ ,                                                                   |                | 490        |                | $\mu A$   |

| Parameter                     | Symbol      | Condition                                                                                                               | Specification |      |     | Units   |
|-------------------------------|-------------|-------------------------------------------------------------------------------------------------------------------------|---------------|------|-----|---------|
|                               |             |                                                                                                                         | Min           | Typ. | Max |         |
|                               |             | mcuClk = stop,<br>Peripheral clock =<br>IRC12M), peripheral<br>off                                                      |               |      |     |         |
| Green mode<br>Working Current | $I_{VDDS2}$ | No load on output<br>( $V_{DD} = 5V$ ,<br>mcuClk = IRC32K,<br>Peripheral clock =<br>IRC32K, LVR off),<br>peripheral off |               | 14   |     | $\mu A$ |
| Sleep mode<br>Working Current | $I_{VDDS3}$ | No load on output<br>( $V_{DD} = 5V$ ,<br>mcuClk = stop,<br>Peripheral clock =<br>stop, LVR off),<br>peripheral off     |               | 5    |     | $\mu A$ |

(\*): These parameters are presented for design guidance only and not tested or guaranteed.

Note:  $V_{OH4} / V_{OL4}$  pins maximum sink/source current are 10 mA;  $V_{OH8} / V_{OL8}$  pins maximum sink/source current are 20 mA.



**7.4 AC Electrical Characteristics ( $T_A = 25^\circ\text{C}$ )**

| Parameter                                      | Symbol                     | Pin/condition                            | Specification |      |     | Units |
|------------------------------------------------|----------------------------|------------------------------------------|---------------|------|-----|-------|
|                                                |                            |                                          | Min           | Typ. | Max |       |
| Main Operation Frequency                       | $F_{MCP}$                  | $X_{IN}$                                 | 0.032         |      | 24  | MHz   |
| Main Crystal Stabilization Time <sup>(*)</sup> |                            | $V_{DD} = 4.5V \sim 5.5V$<br>at 12 MHz   |               |      | 10  | ms    |
|                                                |                            | $V_{DD} = 1.8V \sim 4.5V$<br>at 12 MHz   |               |      | 30  | ms    |
|                                                |                            | $V_{DD} = 4.5V \sim 5.5V$<br>at 32768 Hz |               | 0.5  | 1   | s     |
|                                                |                            | $V_{DD} = 1.8V \sim 4.5V$<br>at 32768 Hz |               |      | 10  | s     |
| T0i Input High, Low Width                      | $t_{INTH}$ ,<br>$t_{INTL}$ | MCU clock = 12 MHz                       | 2             |      |     | us    |
| Interrupt Input High, Low Width (IRQx)         | $t_{INTH}$ ,<br>$t_{INTL}$ | MCU clock = 12 MHz                       | 167           |      |     | ns    |
| RESET Input Low Width                          | $t_{RSL}$                  | RST_NDF = 1,<br>main clock = 12 MHz      | 334           |      |     | ns    |

(\*): These parameters are presented for design guidance only and not tested or guaranteed.

**Input Timing for External Interrupts**

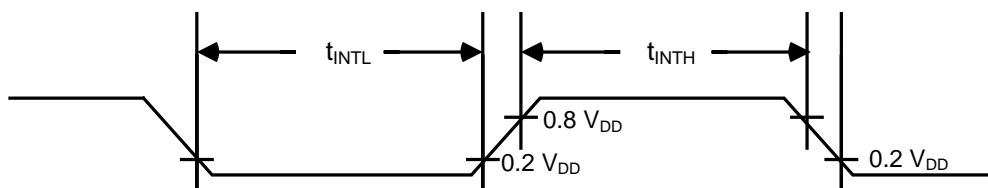

**Input Timing for RESET**

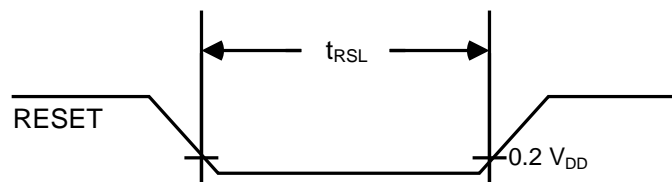

### 7.5 Internal RC Oscillator Temperature Tolerance table

| Parameter                                     | Symbol                    | Pin/condition                                             | Specification |           |     | Units |
|-----------------------------------------------|---------------------------|-----------------------------------------------------------|---------------|-----------|-----|-------|
|                                               |                           |                                                           | Min           | Typ.      | Max |       |
| RC Oscillator Frequency                       | $F_{RCH}$                 | $V_{DD} = 5V$                                             |               | <b>12</b> |     | MHz   |
| Ex-factory Frequency Tolerance <sup>(*)</sup> | $\Delta F_{RCH1}/F_{RCH}$ | Without external oscillator for calibrating 25°C          |               | ±3        |     | %     |
|                                               |                           | Without external oscillator for calibrating 0°C ~ 70°C    |               | ±4        |     | %     |
|                                               |                           | Without external oscillator for calibrating -40°C ~ 125°C |               | ±6        |     | %     |
|                                               |                           | With external oscillator for calibrating -40°C ~ 125°C    |               |           | ±1  | %     |

(\*): These parameters are presented for design guidance only and not tested or guaranteed.

| Parameter                                     | Symbol                    | Pin/condition                                             | Specification |           |     | Units |
|-----------------------------------------------|---------------------------|-----------------------------------------------------------|---------------|-----------|-----|-------|
|                                               |                           |                                                           | Min           | Typ.      | Max |       |
| RC Oscillator Frequency                       | $F_{RCH}$                 | $V_{DD} = 5V$                                             |               | <b>24</b> |     | MHz   |
| Ex-factory Frequency Tolerance <sup>(*)</sup> | $\Delta F_{RCH1}/F_{RCH}$ | Without external oscillator for calibrating 25°C          |               | ±3        |     | %     |
|                                               |                           | Without external oscillator for calibrating 0°C ~ 70°C    |               | ±4.5      |     | %     |
|                                               |                           | Without external oscillator for calibrating -40°C ~ 125°C |               | ±7        |     | %     |
|                                               |                           | With external oscillator for calibrating -40°C ~ 125°C    |               |           | ±1  | %     |

(\*): These parameters are presented for design guidance only and not tested or guaranteed.

## 7.6 A/D Converting Characteristics ( $T_A = 25^\circ\text{C}$ )

| Parameter                                      | Symbol      | Pin/condition                                    | Specification |         |                | Units     |
|------------------------------------------------|-------------|--------------------------------------------------|---------------|---------|----------------|-----------|
|                                                |             |                                                  | Min           | Typ.    | Max            |           |
| Resolution                                     |             |                                                  |               | 10      |                | bit       |
| Integral Nonlinearity Error (INL)              | $E_{IL}$    | $AV_{REF} = V_{DD} = 5V$                         |               | $\pm 2$ |                | LSB       |
| Differential Nonlinearity Error (DNL)          | $E_{DL}$    | $AV_{REF} = V_{DD} = 5V$                         |               | $\pm 2$ |                | LSB       |
| Offset Error                                   | $E_{OFF}$   | $AV_{REF} = V_{DD} = 5V$                         |               | $\pm 2$ |                | LSB       |
| Gain Error                                     | $E_{GN}$    | $AV_{REF} = V_{DD} = 5V$                         |               | $\pm 2$ |                | LSB       |
| Reference Voltage VDD/ExtVref                  | $AV_{REF}$  | Absolute Minimum Value to ensure 2 LSB precision | 2             |         | $V_{DD}$       | V         |
| Reference Voltage BandGap = 1.23V (Note)       |             |                                                  |               | 1.23    |                | V         |
| Reference Voltage BandGap = 2.44V (Note)       |             |                                                  |               | 2.44    |                | V         |
| Full Scale Range                               | $V_{ADCIN}$ |                                                  | $V_{SS}$      |         | $V_{REF}$      | V         |
| Recommended Impedance of Analog Voltage Source | $Z_{AIN}$   |                                                  |               |         | 10             | $k\Omega$ |
| $V_{REF}$ Input Current                        | $I_{REF}$   | DAC base on different $V_{in}$                   | 10            |         | 100            | $\mu A$   |
|                                                |             | Comparator                                       |               |         | 20             | $\mu A$   |
| Conversion Time                                | $T_{CT}$    | main clock = 12 MHz                              | 16            |         |                | ADC_clk   |
| Ground Voltage <sup>(*)</sup>                  | $AV_{SS}$   |                                                  | $V_{SS}$      |         | $V_{SS} + 0.3$ | V         |
| ADC Working Current <sup>(*)</sup>             | $I_{ADC}$   | $AV_{REF} = V_{DD} = 5V$                         |               | 0.2     |                | mA        |
|                                                |             | $AV_{REF} = V_{DD} = 5V$ at Power Down mode      |               |         | 1              | $\mu A$   |

(\*): These parameters are presented for design guidance only and not tested or guaranteed.

Note: When selecting Bandgap as reference voltage, please pay attention to the power voltage range (VDD) and refer to section 7.7 Bandgap Electrical Characteristics for more details.

**ADC ENOB (Effective number of bits)**

| Parameter | Pin/condition<br>ADC convert time clock base = 1 MHz | Specification |      |     | Units |
|-----------|------------------------------------------------------|---------------|------|-----|-------|
|           |                                                      | Min           | Typ. | Max |       |
| ENOB      | AV <sub>REF</sub> = VDD = 5V                         |               | 9    |     | bit   |
|           | AV <sub>REF</sub> = VDD = 4V                         |               | 8    |     | bit   |
|           | AV <sub>REF</sub> = VDD = 3V                         |               | 8    |     | bit   |
|           | AV <sub>REF</sub> = VDD = 2V                         |               | 8    |     | bit   |
|           | AV <sub>REF</sub> = 2.44V (Bandgap) VDD > 2.7V       |               | 8    |     | bit   |
|           | AV <sub>REF</sub> = 1.23V (Bandgap) VDD > 2.0V       |               | 6    |     | bit   |

## 7.7 Bandgap Electrical Characteristic

| Parameter                            | Symbol            | Pin/condition                       | Specification |                    |            | Units |
|--------------------------------------|-------------------|-------------------------------------|---------------|--------------------|------------|-------|
|                                      |                   |                                     | Min           | Typ.               | Max        |       |
| Operating Voltage <sup>(*)</sup>     |                   | BGP = 1.23V                         | 1.8           |                    | 5.5        | V     |
| Operating Voltage <sup>(*)</sup>     |                   | BGP = 2.44V                         | <b>2.7</b>    |                    | <b>5.5</b> | V     |
| Operating Temperature <sup>(*)</sup> |                   |                                     | -40           |                    | 105        | °C    |
| Bandgap Voltage                      | V <sub>BDIE</sub> | V <sub>DD</sub> = 5V<br>Temp = 25°C |               | 1.23±1%<br>2.44±1% |            | V     |
| Voltage Variation                    | V <sub>BSP</sub>  | BGP = 1.23V                         |               | 5                  |            | mV    |
|                                      |                   | BGP = 2.44V                         |               | 10                 |            | mV    |
| Temperature Variation                | V <sub>BTP</sub>  | Temp = -40°C ~ 105°C<br>BGP = 1.23V |               | ±25                |            | mV    |
|                                      |                   | Temp = -40°C ~ 105°C<br>BGP = 2.44V |               | ±50                |            | mV    |

(\*): These parameters are presented for design guidance only and not tested or guaranteed.

**Note:** Internal reference voltage Bandgap is calibrated at 2.44V±1% @VDD = 5V out of the factory. Please refer to the section 6.19 for the actual voltage value.

## 7.8 Low Voltage Reset (LVR), Low Voltage Detection (LVD) & Low Voltage Detection Reset (LVDR) Electrical Characteristics ( $T_A = 25^\circ\text{C}$ )

| Parameter                                   | Symbol     | Pin/condition            | Specification |          |     | Units         |
|---------------------------------------------|------------|--------------------------|---------------|----------|-----|---------------|
|                                             |            |                          | Min           | Typ.     | Max |               |
| LVR Voltage                                 | $V_{LVR}$  | $T_A = 25^\circ\text{C}$ |               | 1.5      |     | V             |
| LVR Working Current                         | $I_{DDPR}$ | $V_{DD} = 5V \pm 10\%$   |               | 5        |     | $\mu\text{A}$ |
| LVD & LVDR Response Time                    |            |                          |               | 120      |     | $\mu\text{S}$ |
| Low Voltage Detection Range Tolerance       | $V_{LVD}$  |                          |               | $\pm 10$ |     | %             |
| Low Voltage Detection Reset Range Tolerance | $V_{LVDR}$ |                          |               | $\pm 10$ |     | %             |

## 7.9 Thermal Resistance Notice

| Parameter | Symbol        | Feature                               | Typ. | Units                     | Condition          |
|-----------|---------------|---------------------------------------|------|---------------------------|--------------------|
| TH01      | $\theta_{JA}$ | Thermal Resistance (Junction to Air)  | 34   | $^\circ\text{C}/\text{W}$ | 32-pin QFN package |
| TH02      | $\theta_{JC}$ | Thermal Resistance (Junction to Case) | 1.1  | $^\circ\text{C}/\text{W}$ | 32-pin QFN package |
| TH03      | TJMAX         | Maximum Junction Temperature          | 120  | $^\circ\text{C}$          | 32-pin QFN package |

| Parameter | Symbol        | Feature                               | Typ. | Units                     | Condition           |
|-----------|---------------|---------------------------------------|------|---------------------------|---------------------|
| TH01      | $\theta_{JA}$ | Thermal Resistance (Junction to Air)  | 90   | $^\circ\text{C}/\text{W}$ | 20-pin SSOP package |
| TH02      | $\theta_{JC}$ | Thermal Resistance (Junction to Case) | 30   | $^\circ\text{C}/\text{W}$ | 20-pin SSOP package |
| TH03      | TJMAX         | Maximum Junction Temperature          | 125  | $^\circ\text{C}$          | 20-pin SSOP package |

| Parameter | Symbol        | Feature                               | Typ. | Units                     | Condition           |
|-----------|---------------|---------------------------------------|------|---------------------------|---------------------|
| TH01      | $\theta_{JA}$ | Thermal Resistance (Junction to Air)  | 45   | $^\circ\text{C}/\text{W}$ | 10-pin MSOP package |
| TH02      | $\theta_{JC}$ | Thermal Resistance (Junction to Case) | 120  | $^\circ\text{C}/\text{W}$ | 10-pin MSOP package |
| TH03      | TJMAX         | Maximum Junction Temperature          | 125  | $^\circ\text{C}$          | 10-pin MSOP package |

## 8. Application Circuits

### 8.1 Power Supply

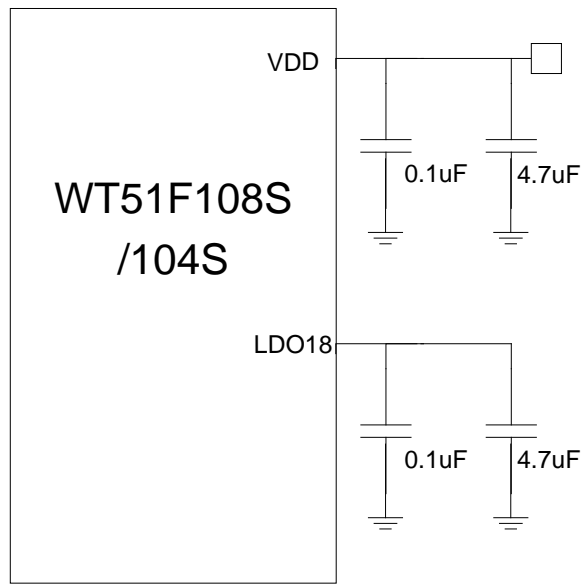

## 8.2 Oscillator Circuits

### 8.2.1 External 1 MHz ~ 24 MHz Crystal Oscillator

Example

|                    |                      |
|--------------------|----------------------|
| Crystal Oscillator | C1, C2 = 10pF ~ 33pF |
| Ceramic Resonator  | C1, C2 = 10pF ~ 33pF |

\* The example load capacitor value (C1, C2, C3, C4) is common value but may not be appropriate for some crystal or ceramic resonator.

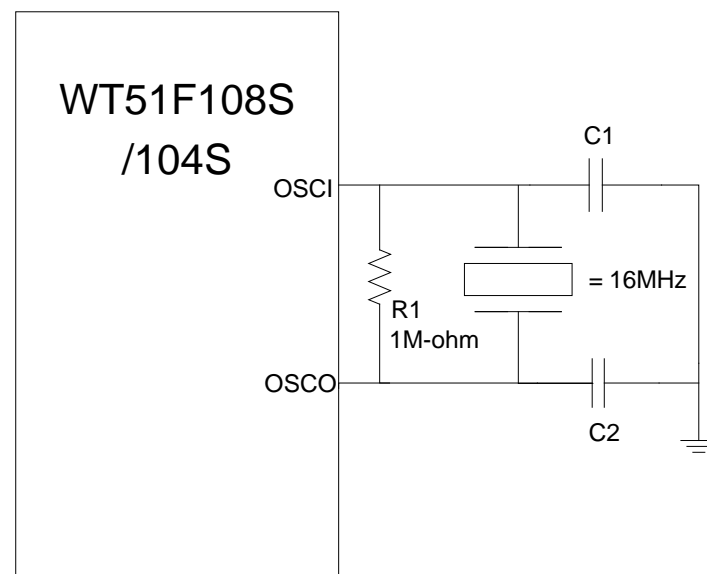
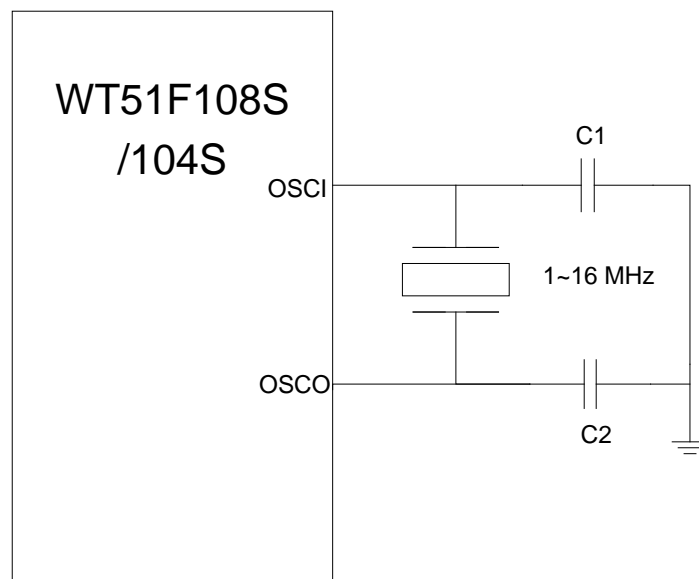

**Note: WT51F108S/104S has built-in internal RC oscillators, thus external crystal oscillators are not essential. If for more precise application, external crystal oscillator is available for use.**

**8.2.2 External 32.768 kHz Crystal Oscillator**

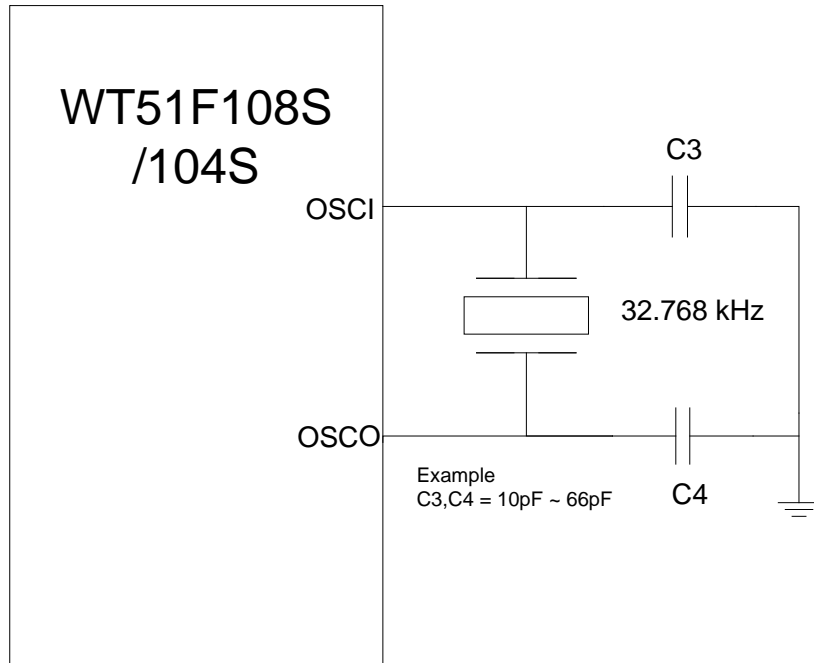



### 8.3 RESET Circuit

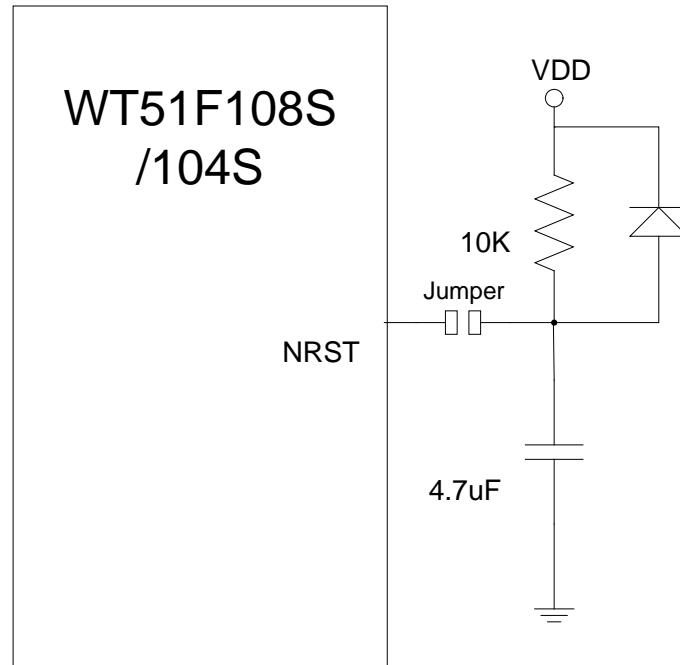

**Note:** Reset Circuit will affect programming process, and it requires adding Jumper for isolation.

**8.4 Standard Circuit**

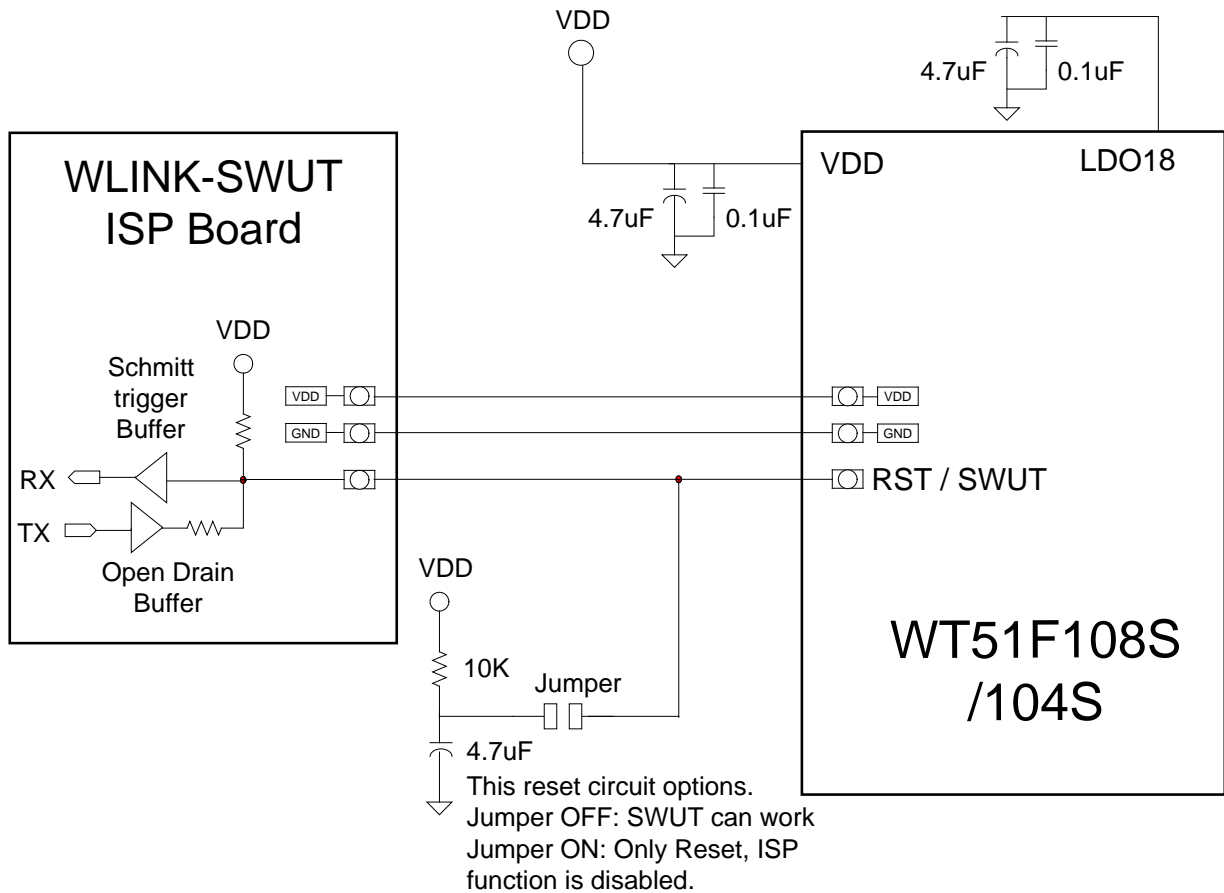

**8.5 Development board circuits**

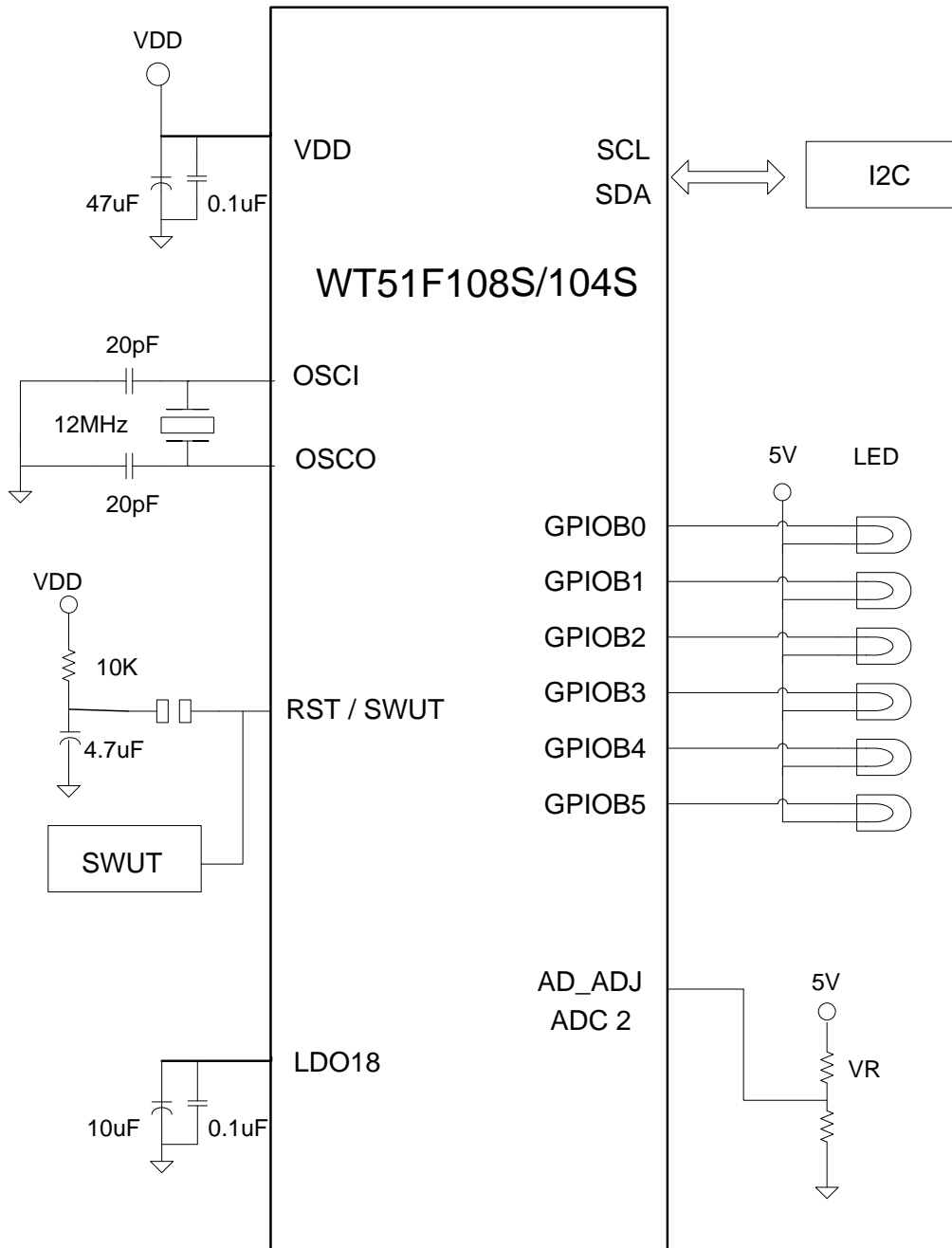

## 9. Product Naming Rule

| WT | Consumption market | LCD function | Seed code (Family) | Flash Size (K Bytes) |   | Remarks                                                                                                                                                                   |
|----|--------------------|--------------|--------------------|----------------------|---|---------------------------------------------------------------------------------------------------------------------------------------------------------------------------|
| WT | 5                  | 1F           | 1                  | 0                    | 4 | 5: MCU/DSP embedded, used in general-purpose or consumption market related product.<br>1X: 8-bit MCU<br>1F: Flash type 8-bit MCU without LCD function                     |
|    |                    |              | 1                  | 0                    | 8 |                                                                                                                                                                           |
|    |                    |              | 1                  | 1                    | 6 |                                                                                                                                                                           |
|    |                    |              | 5                  | 1                    | 6 |                                                                                                                                                                           |
| WT | 5                  | 6F           | 1                  | 0                    | 8 | 5: MCU/DSP embedded, used in general-purpose or consumption market related product.<br>6X: LCD back light module controller<br>6F: Flash type 8-bit MCU with LCD function |
|    |                    |              | 2                  | 1                    | 6 |                                                                                                                                                                           |
|    |                    |              | 2                  | 3                    | 2 |                                                                                                                                                                           |
|    |                    |              | 2                  | 4                    | 8 |                                                                                                                                                                           |

## 10. Ordering Information

| Package Type                  | Package Outline | Part Number       |
|-------------------------------|-----------------|-------------------|
| 32-pin QFN                    | 5mm x 5mm       | WT51F108S-UG32AWT |
| 20-pin SSOP                   | 150 mil         | WT51F108S-OG20AWT |
| 16-pin SOP                    | 150 mil         | WT51F108S-SG16AWT |
| 10-pin MSOP                   | 118 mil         | WT51F108S-MG10BWT |
| Wafer form<br>or<br>Chip form | -               | WT51F108SHXXXWT   |

| Package Type                  | Package Outline | Part Number       |
|-------------------------------|-----------------|-------------------|
| 32-pin QFN                    | 5mm x 5mm       | WT51F104S-UG32AWT |
| 20-pin SSOP                   | 150 mil         | WT51F104S-OG20AWT |
| 16-pin SOP                    | 150 mil         | WT51F104S-SG16AWT |
| 10-pin MSOP                   | 118 mil         | WT51F104S-MG10BWT |
| Wafer form<br>or<br>Chip form | -               | WT51F104SHXXXWT   |

## 11. Pad Diagram & Location Table

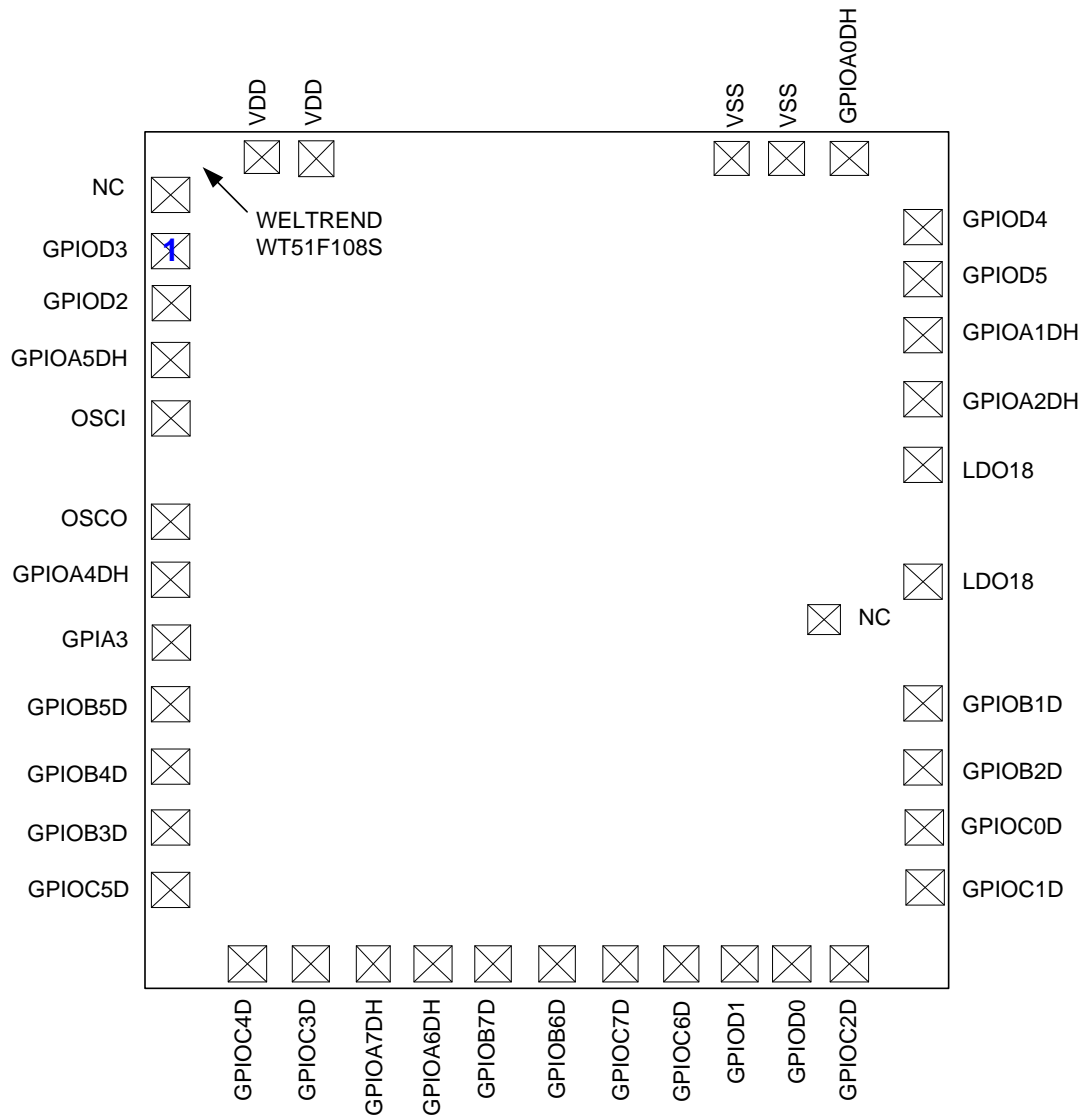

| No  | Name     | X      | Y       | No  | Name     | X       | Y       |
|-----|----------|--------|---------|-----|----------|---------|---------|
| 1*  | GPIOD3   | 46.26  | 1278.76 | 20  | GPIOD1   | 1022.76 | 46.26   |
| 2*  | GPIOD2   | 46.26  | 1188.76 | 21  | GPIOD0   | 1112.76 | 46.26   |
| 3*  | GPIOA5DH | 46.26  | 1090.26 | 22  | GPIOC2D  | 1211.74 | 46.26   |
| 4*  | OSCI     | 46.26  | 991.76  | 23* | GPIOC1D  | 1340.74 | 175.26  |
| 5*  | OSCO     | 46.26  | 810.76  | 24* | GPIOC0D  | 1340.74 | 282.26  |
| 6*  | GPIOA4DH | 46.26  | 712.26  | 25* | GPIOB2D  | 1340.74 | 389.26  |
| 7*  | GPIA3    | 46.26  | 604.26  | 26* | GPIOB1D  | 1340.74 | 496.26  |
| 8*  | GPIOB5D  | 46.26  | 496.26  | 27* | LDO18    | 1340.74 | 708.01  |
| 9*  | GPIOB4D  | 46.26  | 389.26  | 28* | LDO18    | 1340.74 | 911.26  |
| 10* | GPIOB3D  | 46.26  | 282.26  | 29* | GPIOA2DH | 1340.74 | 1025.74 |
| 11* | GPIOC5D  | 46.26  | 175.26  | 30* | GPIOA1DH | 1340.74 | 1132.74 |
| 12* | GPIOC4D  | 175.26 | 46.26   | 31* | GPIOD5   | 1340.74 | 1231.24 |
| 13  | GPIOC3D  | 282.26 | 46.26   | 32* | GPIOD4   | 1340.74 | 1321.24 |
| 14  | GPIOA7DH | 389.26 | 46.26   | 33  | GPIOA0DH | 1211.74 | 1441.74 |
| 15  | GPIOA6DH | 496.26 | 46.26   | 34  | VSS      | 1104.74 | 1441.74 |
| 16  | GPIOB7D  | 603.26 | 46.26   | 35  | VSS      | 1006.74 | 1441.74 |
| 17  | GPIOB6D  | 710.26 | 46.26   | 36  | VDD      | 294.26  | 1441.74 |
| 18  | GPIOC7D  | 817.26 | 46.26   | 37  | VDD      | 195.76  | 1441.74 |
| 19  | GPIOC6D  | 924.26 | 46.26   |     |          |         |         |

**Notes:**

1. *The origin of pad location shown here is at lower-left corner of die.*
2. **PAD Window**  
 (a) A type: 63 um x 66 um  
 (b) B type: 66 um x 63 um (\*)
3. *To stabilize the supply voltages, please connect 0.1uF and 4.7uF bypass capacitors.*  
 (a) *between VDD and VSS.*  
 (b) *between LDO18 and VSS.*
4. **NC pin, no connection for normal application.**
5. **All VDD pins need connect together. (No: 36, 37)**
6. **All VSS pins need connect together. (No: 34, 35)**
7. **All LDO18 pins need connect together. (No: 27, 28)**

## 12. Package Dimension

### 12.1 32-Pin QFN

Quad Flat No-Lead Plastic Package

QFN-32 PIN

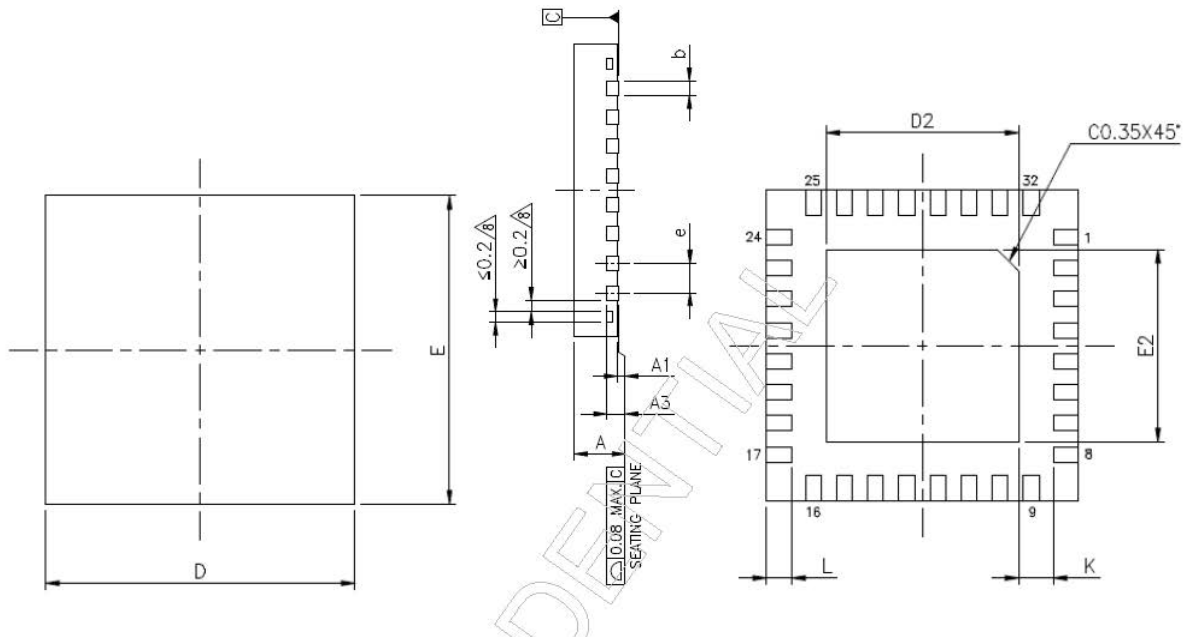

| SYMBOLS | MIN       | NOR  | MAX  |
|---------|-----------|------|------|
| A       | 0.70      | 0.75 | 0.80 |
| A1      | 0.00      | 0.02 | 0.05 |
| A3      | 0.203 REF |      |      |
| b       | 0.18      | 0.25 | 0.30 |
| D       | 5.00 BSC  |      |      |
| E       | 5.00 BSC  |      |      |
| e       | 0.50 BSC  |      |      |
| L       | 0.35      | 0.40 | 0.45 |
| K       | 0.20      | —    | —    |
| D2      | 3.05      | 3.10 | 3.25 |
| E2      | 3.05      | 3.10 | 3.25 |

UNIT: mm

**NOTES:**

1. JEDEC outline : MO-220
2. Dimension "b" applies to metallized terminal and is measured between 0.15mm and 0.30mm from the terminal tip. If the terminal has the optional radius on the other end of the terminal, the dimension "b" should not be measured in that radius area.
3. Bilateral coplanarity zone applies to the exposed heat sink slug as well as the terminals.

**12.2 20-Pin SSOP**

**Shrink Small Outline Package**

**150MIL/SSOP-20PIN**

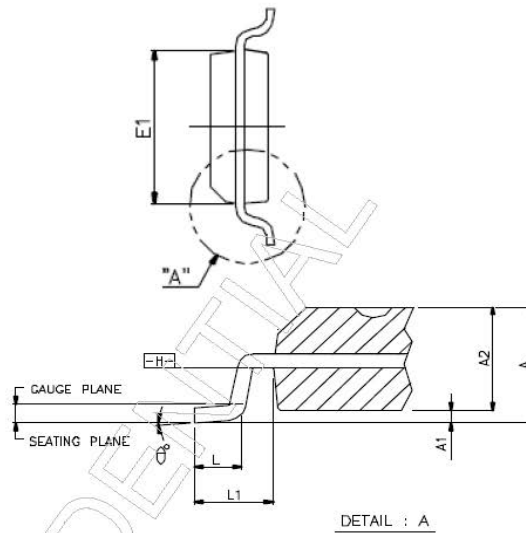
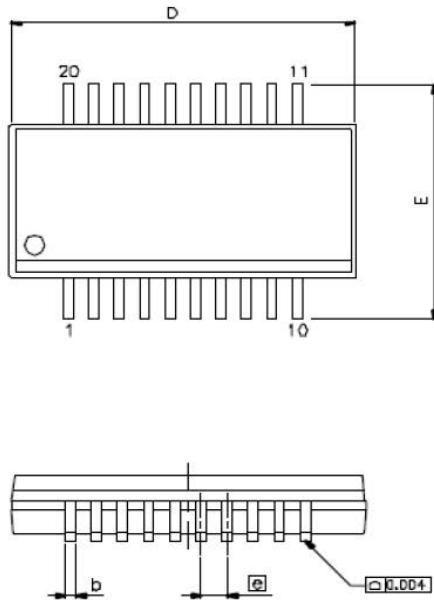

| SYMBOLS | MIN       | NOR   | MAX   |
|---------|-----------|-------|-------|
| A       | 1.346     | 1.626 | 1.753 |
| A1      | 0.102     | 0.152 | 0.254 |
| A2      | -         | -     | 1.499 |
| b       | 0.203     | -     | 0.305 |
| C       | 0.178     | -     | 0.254 |
| D       | 8.560     | 8.661 | 8.738 |
| E       | 5.791     | 5.994 | 6.198 |
| e       | 0.635 BSC |       |       |
| L       | 0.406     | 0.635 | 1.270 |
| L1      | 1.041 BSC |       |       |
| θ°      | 0         | -     | 8     |

UNIT: mm

**NOTES:**

1. JEDEC outline : MO-137AD
2. Dimension "D" does not include mold protrusion or gate burrs. Mold protrusions and gate burrs shall not exceed 0.152mm per side. Dimension "E1" does not include inter-lead mold protrusions. Inter-lead mold protrusion shall not exceed 0.254mm per side.
3. Dimension "b" does not include dambar protrusion/intrusion. Allowable dambar protrusion shall be 0.102mm total in excess of "b" dimension at maximum material condition. Dambar intrusion shall not reduce dimension "b" by more than 0.051mm at least.

|         |          |                    |
|---------|----------|--------------------|
| PREPARE | Cynthia  | DATE:<br>2012/7/26 |
| CHECK   | Lawrence | DATE:<br>2012/7/26 |
| APPROVE | Eric     | DATE:<br>2012/7/26 |



**12.3 16-Pin SOP**

**Small Outline Package**

**150MIL/SOP-16 PIN**

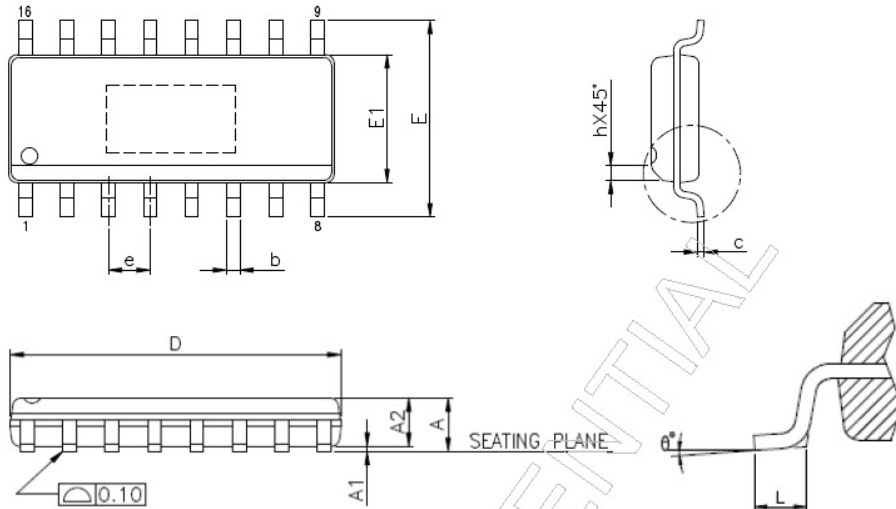

| SYMBOLS        | MIN      | MAX  |
|----------------|----------|------|
| A              | -        | 1.75 |
| A1             | 0.10     | 0.25 |
| A2             | 1.25     |      |
| b              | 0.31     | 0.51 |
| c              | 0.10     | 0.25 |
| D              | 9.90 BSC |      |
| E              | 6.00 BSC |      |
| E1             | 3.90 BSC |      |
| e              | 1.27 BSC |      |
| L              | 0.40     | 1.27 |
| h              | 0.25     | 0.50 |
| $\theta^\circ$ | 0        | 8    |

UNIT: mm

**NOTES:**

1. JEDEC outline : MS-012 AC REV.F
2. Dimension "D" does not include mold flash, protrusions or gate burrs. Mold flash, protrusions and gate burrs shall not exceed 0.15mm per side.
3. Dimension "E1" does not include inter-lead flash, or protrusions. Inter-lead flash and protrusions shall not exceed 0.25mm per side.

|         |          |                    |
|---------|----------|--------------------|
| PREPARE | Cynthia  | DATE:<br>2012/7/24 |
| CHECK   | Lawrence | DATE:<br>2012/7/24 |
| APPROVE | Eric     | DATE:<br>2012/7/24 |

**12.4 10-Pin MSOP**

Micro Small Outline Package

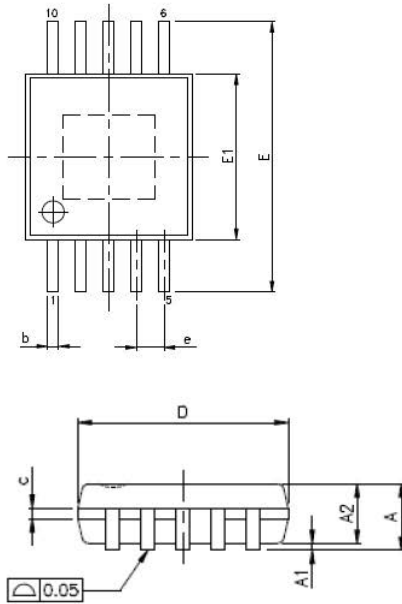

MSOP-10 PIN

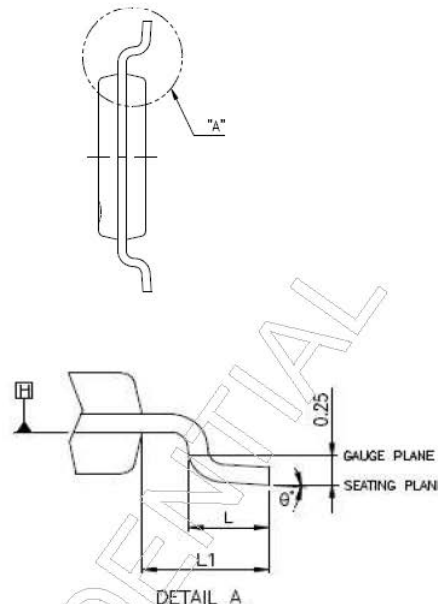

| SYMBOLS        | MIN      | NOR  | MAX  |
|----------------|----------|------|------|
| A              | -        | -    | 1.10 |
| A1             | 0.00     | -    | 0.15 |
| A2             | 0.75     | 0.85 | 0.95 |
| b              | 0.17     | -    | 0.27 |
| c              | 0.08     | -    | 0.23 |
| D              | 3.00 BSC |      |      |
| E              | 4.90 BSC |      |      |
| E1             | 3.00 BSC |      |      |
| e              | 0.50 BSC |      |      |
| L              | 0.40     | 0.60 | 0.80 |
| L1             | 0.95 REF |      |      |
| $\theta^\circ$ | 0        | -    | 8    |

UNIT: mm

NOTES:

1. JEDEC outline : MO-187 BA
2. Dimension "D" does not include mold flash, protrusions or gate burrs. Mold flash, protrusions or gate burrs shall not exceed 0.15mm per end. Dimension "E1" does not include inter-lead flash or protrusion. Inter-lead flash or protrusion shall not exceed 0.15mm per side.
3. Dimension "b" does not include dambar protrusion. Allowable dambar protrusion shall be 0.08mm total in excess of the "b" dimension at maximum material condition. The dambar cannot be located on the lower radius of the foot. Minimum space between protrusion and an adjacent lead shall not be less than 0.07mm.
4. "D" and "E1" dimensions are determined at datum H.

|         |          |                    |
|---------|----------|--------------------|
| PREPARE | Cynthia  | DATE:<br>2012/7/25 |
| CHECK   | Lawrence | DATE:<br>2012/7/25 |
| APPROVE | Eric     | DATE:<br>2012/7/25 |

### 13. Development Tools

WT51F108S/104S can work together with Keil C51 development environment. WLINK adaptor can link PC and WT51F108S/104S evaluation board via ICE/ISP driver, and the debugger tools, demo board application software can perform In-Circuit Emulator (ICE) and In-system Programming (ISP) in Windows 98/2000/XP/Win7.

The development kits are illustrated in the figure below:

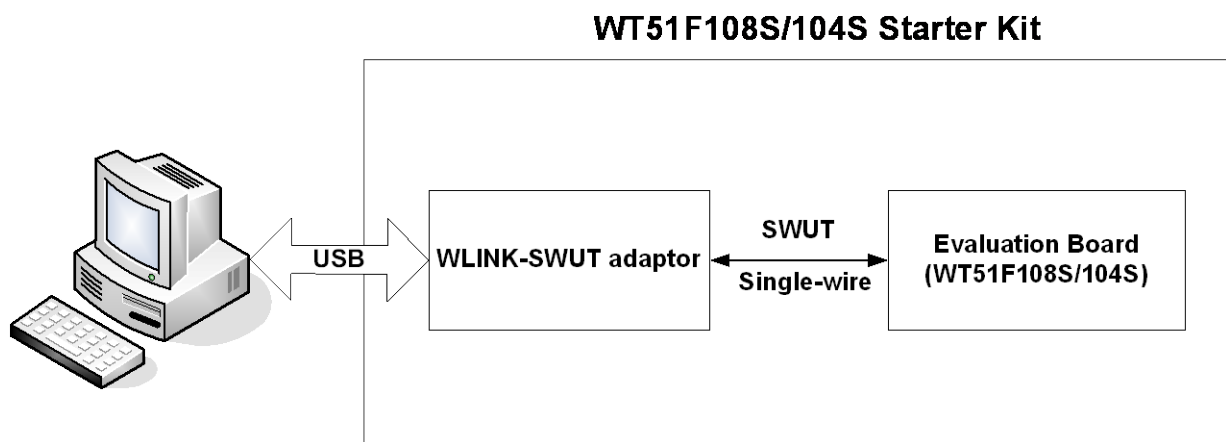

**Development Tools List:**

Please go to Weltrend' s website <http://www.weltrend.com.tw/> for more information.

|                            |                                             |                                           |                                                                                                             |
|----------------------------|---------------------------------------------|-------------------------------------------|-------------------------------------------------------------------------------------------------------------|
| <b>Product Information</b> | <b>General Purpose IC</b>                   | ADC Type MCU                              | WT51F104 Product Spec                                                                                       |
|                            |                                             |                                           | WT51F116/WT51F108 Product Spec                                                                              |
|                            |                                             |                                           | <a href="#">WT51F108S/WT51F104S Product Spec</a>                                                            |
|                            |                                             | ADC+LCD Type MCU                          | WT56F216 Product Spec                                                                                       |
|                            |                                             |                                           | WT56F108 Product Spec                                                                                       |
|                            |                                             |                                           | WT56F248/WT56F232 Product Spec                                                                              |
| <b>Technical Support</b>   | <b>Supporting Tools/ General Purpose IC</b> | ICE/ISP                                   | <b>WA001</b> WLINK-SWUT Adapter                                                                             |
|                            |                                             | Mass Production Programmer                | <b>WA004</b> WLINK-SWUT-M4S                                                                                 |
|                            |                                             | Mass Production Programmer Daughter Board | <b>WS001</b> WLINK-SWUT-M4S Daughter Board<br>Support WT56F216/WT56F232/WT56F248 MCU<br>RG44AWT LQFP 44 PKG |
|                            |                                             |                                           | <b>WS003</b> WLINK-SWUT-M4S Daughter Board<br>Support WT56F216 MCU<br>SG28AWT SOP28 PKG                     |
|                            |                                             |                                           | <b>WS004</b> WLINK-SWUT-M4S Daughter Board<br>Support WT51F104/WT51F116/WT51F108 MCU<br>OG20AWT SSOP20 PKG  |
|                            |                                             |                                           | <b>WS005</b> WLINK-SWUT-M4S Daughter Board<br>Support WT51F104 MCU<br>SG140WT SOP14 PKG<br>SG080WT SOP8 PKG |
|                            |                                             |                                           | <b>WS006</b> WLINK-SWUT-M4S Daughter Board<br>Support WT51F104 MCU<br>MG10AWT MSOP10 PKG                    |
|                            |                                             |                                           | <b>WS007</b> WLINK-SWUT-M4S Daughter Board<br>Support WT56F108 MCU<br>RG64AWT LQFP64 PKG                    |
|                            |                                             |                                           | <b>WS009</b> WLINK-SWUT-M4S Daughter Board<br>Support WT51F116/WT51F108 MCU<br>UG32AWT QFN32 PKG            |
|                            |                                             |                                           | <b>WS010</b> WLINK-SWUT-M4S Daughter Board<br>Support WT51F116/WT51F108 MCU<br>MG10BWT MSOP10 PKG           |
|                            |                                             |                                           | <b>WS011</b> WLINK-SWUT-M4S Daughter Board<br>Support WT56F248/WT56F232 MCU<br>RG64AWT LQFP64 PKG           |
|                            |                                             |                                           | <b>WS012</b> WLINK-SWUT-M4S Daughter Board<br>Support WT56F248/WT56F232 MCU<br>UG32AWT QFN32 PKG            |
|                            |                                             |                                           | <b>WS013</b> WLINK-SWUT-M4S Daughter Board<br>Support WT56F108 MCU<br>RG44AWT LQFP 44 PKG                   |
|                            |                                             |                                           | <b>WS014</b> WLINK-SWUT-M4S Daughter Board<br>Support WT56F108 MCU<br>SG28AWT SOP28 PKG                     |

|                                                    |                                                     |                                             |                                                                                                          |
|----------------------------------------------------|-----------------------------------------------------|---------------------------------------------|----------------------------------------------------------------------------------------------------------|
| <b>Technical Support</b>                           | <b>Supporting Tools/<br/>General Purpose IC</b>     | Mass Production Programmer Daughter Board   | <a href="#">WS015</a> WLINK-SWUT-M4S Daughter Board Support WT51F108S/WT51F104S MCU UG32AWT QFN32 PKG    |
|                                                    |                                                     |                                             | <a href="#">WS016</a> WLINK-SWUT-M4S Daughter Board Support WT51F108S/WT51F104S MCU OG20AWT SSOP20 PKG   |
|                                                    |                                                     |                                             | <a href="#">WS017</a> WLINK-SWUT-M4S Daughter Board Support WT51F108S / WT51F104S MCU MG10BWT MSOP10 PKG |
|                                                    |                                                     |                                             | <a href="#">WS018</a> WLINK-SWUT-M4S Daughter Board Support WT51F108S / WT51F104S MCU SG16WT SOP16 PKG   |
|                                                    |                                                     | Evaluation Board                            | <b>WB000</b> WT56F216 EV Board                                                                           |
|                                                    |                                                     |                                             | <b>WB001</b> WT51F104 EV Board                                                                           |
|                                                    |                                                     |                                             | <b>WB005</b> WT56F216 Starter Kit Board                                                                  |
|                                                    |                                                     |                                             | <b>WB006</b> WT51F104 Starter Kit Board                                                                  |
|                                                    |                                                     |                                             | <b>WB007</b> WT56F108 Starter Kit Board                                                                  |
|                                                    |                                                     |                                             | <b>WB008</b> WT51F116/WT51F108 Starter Kit Board                                                         |
|                                                    | <b>Technical Data/<br/>General Purpose IC</b>       | Starter Kit                                 | <b>WK000</b> WT56F216 Starter Kit                                                                        |
|                                                    |                                                     |                                             | <b>WK001</b> WT51F104 Starter Kit                                                                        |
|                                                    |                                                     |                                             | <b>WK004</b> WT56F108 Starter Kit                                                                        |
|                                                    |                                                     |                                             | <b>WK005</b> WT51F108S/104S Starter Kit                                                                  |
|                                                    |                                                     |                                             | <b>WK007</b> WT56F248/WT56F232 Starter Kit                                                               |
|                                                    |                                                     |                                             | <a href="#">WK011</a> WT51F108S/WT51F104S Starter Kit                                                    |
|                                                    |                                                     | WLINK Adapter Operation Manual              | <b>Doc2</b> WLINK-SWUT Adapter Installation Manual                                                       |
|                                                    |                                                     | Mass Production Programmer Operation Manual | <b>Doc26</b> WLINK-SWUT-M4S Operation Manual                                                             |
|                                                    |                                                     | ICE/ISP Operation Manual                    | <b>Doc6</b> WLINK ICE Operation Manual (uVision IDE Version)                                             |
|                                                    |                                                     |                                             | <b>Doc8</b> WLINK-SWUT ISP Operation Manual (for Alone Programmer)                                       |
| Evaluation Board Operation Manual                  | <b>Doc12</b> WT56F216 EV Board Operation Manual     |                                             |                                                                                                          |
|                                                    | <b>Doc13</b> WT51F104 EV Board Operation Manual     |                                             |                                                                                                          |
|                                                    | <b>Doc21</b> WT56F216 Starter Kit Quick Start Guide |                                             |                                                                                                          |
|                                                    | <b>Doc22</b> WT51F104 Starter Kit Quick Start Guide |                                             |                                                                                                          |
|                                                    | <b>Doc23</b> WT56F216 Starter Kit Operation Manual  |                                             |                                                                                                          |
| <b>Doc24</b> WT51F104 Starter Kit Operation Manual |                                                     |                                             |                                                                                                          |

|                                                                                   |                                                  |                                                      |                                                                                                                |
|-----------------------------------------------------------------------------------|--------------------------------------------------|------------------------------------------------------|----------------------------------------------------------------------------------------------------------------|
| <b>Technical Support</b>                                                          | <b>Technical Data/<br/>General Purpose IC</b>    | Evaluation Board Operation Manual                    | <b>Doc27</b> WT56F108 Starter Kit Operation Manual                                                             |
|                                                                                   |                                                  |                                                      | <b>Doc28</b> WT51F108S/104S Starter Kit Operation Manual                                                       |
|                                                                                   |                                                  |                                                      | <b>Doc30</b> WT56F248/WT56F232 Starter Kit Operation Manual                                                    |
|                                                                                   |                                                  |                                                      | <b>Doc35</b> <a href="#">WT51F108S/WT51F104S Starter Kit Operation Manual</a>                                  |
|                                                                                   |                                                  | Mass Production ISP and Supplier Contact Information | <b>Doc20</b> Mass Production ISP Supplier                                                                      |
|                                                                                   | <b>Software Download/<br/>General Purpose IC</b> | WLINK Adapter Driver                                 | <b>SW2</b> WLINK-SWUT Adapter Driver                                                                           |
|                                                                                   |                                                  |                                                      | <b>SW2</b> WLINK-SWUT Adapter Driver                                                                           |
|                                                                                   |                                                  |                                                      | <b>SW6</b> WLINK-SWUT ICE Driver (for uVision IDE)                                                             |
|                                                                                   |                                                  | ICE Driver/ISP Program                               | <b>SW8</b> WLINK-SWUT ISP Driver (for uVision IDE)                                                             |
|                                                                                   |                                                  |                                                      | <b>SW9</b> WLINK-SWUT ISP Program (for Alone Programmer)                                                       |
|                                                                                   |                                                  |                                                      | <b>SW17</b> Auto Install WLINK-SWUT ICE & ISP Driver (for uVision IDE) WLINK-SWUT ISP Driver (for uVision IDE) |
|                                                                                   |                                                  |                                                      | <b>SW13</b> WT56F216 EV Board Example Program                                                                  |
|                                                                                   |                                                  | Example Program                                      | <b>SW14</b> WT51F104 EV Board Example Program                                                                  |
|                                                                                   |                                                  |                                                      | <b>SW18</b> WT56F216 Starter Kit Board Example Program                                                         |
|                                                                                   |                                                  |                                                      | <b>SW19</b> WT51F104 Starter Kit Board Example Program                                                         |
|                                                                                   |                                                  |                                                      | <b>SW21</b> WT56F108 Starter Kit Board Example Program                                                         |
| <b>SW22</b> WT51F116/WT51F108 Starter Kit Board Example Program                   |                                                  |                                                      |                                                                                                                |
| <b>SW25</b> WT56F248/WT56F232 Starter Kit Board Example Program                   |                                                  |                                                      |                                                                                                                |
| <b>SW30</b> <a href="#">WT51F108S/WT51F104S Starter Kit Board Example Program</a> |                                                  |                                                      |                                                                                                                |

## 14. Revision History

| Version | History       | Date      |
|---------|---------------|-----------|
| 1.0     | Initial issue | June 2016 |